

ED8200 Series

Panic Listed

ED8200B Series

1-1/2 Hour Fire Rated

Pushbar

Exit Device

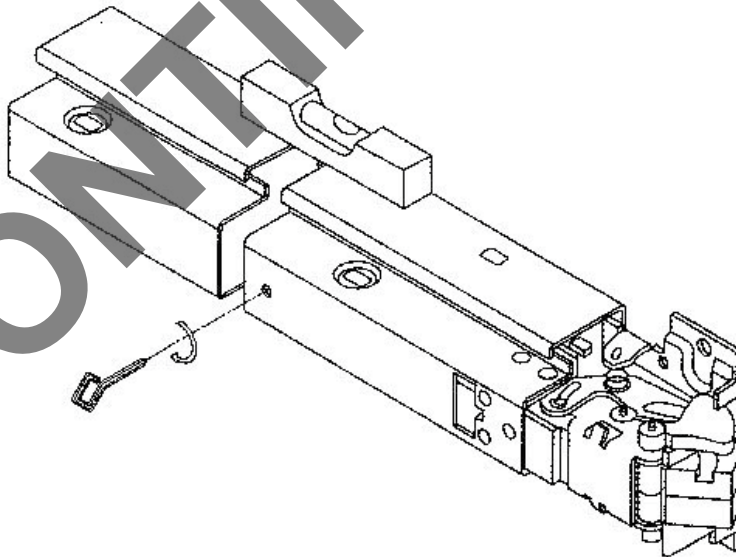

Attention Installer:

Failure to follow these instructions could affect operation of this product and void warranty.

Some trim designs are handed when used with this device (see trim instructions).

Exit devices must be securely fastened to properly reinforced doors with fasteners which will not loosen or pull out. Add reinforcement when necessary.

Before installing: Be sure exit device is the proper hand for your door.

Use enclosed template to assure proper operation.

WARNING

This product can expose you to lead which is known to the state of California to cause cancer and birth defects or other reproductive harm. For more information go to www.P65warnings.ca.gov.

1

General Information

How To Determine Hand of Door

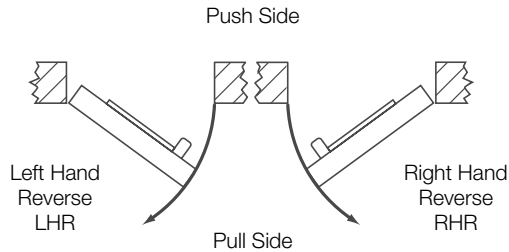

Dogging (8200 Only):

Feature to hold bolts retracted and touchpad depressed for push-pull door operation.

To Dog Device:

- Insert dogging key.
- Hold touchbar depressed.
- Turn key 1/4 turn clockwise.

Not a feature on fire rated devices.

ED8200 ED8200B

	ED8200	ED8200B	
Latch Assembly	2	2	#12-24 x 3/4" Phillips Pan Head Machine Screws, #12 Internal Washers (Wood doors: #12 x 1-1/4" Phillips Pan Head, Type A, Tapping Screws)
Rear Bracket	2	2	#12-24 x 3/4" Phillips Pan Head Machine Screws, #12 Internal Washers (Wood doors: #12 x 1-1/4" Phillips Pan Head, Type A, Tapping Screws)
Strike	2	2	#12-24 x 3/4" Phillips Pan Head Machine Screws, #12 Internal Washers (Wood doors: #12 x 1-1/4" Phillips Pan Head, Type A, Tapping Screws)
Front Bar Insert	1	1	#8-32 x 1" Phillips Pan Head Machine Screw
Rear Cover	1	1	#8-32 x 1" Phillips Flat Head Machine Screw with External Washer
Front Cover	2	2	#8-32 x 1/2" Phillips Flat Head Machine Screw, Type F, with External Washers
Non-Reinforced Door	-	4	#12-24 x 1-21/32" Sex Nuts
Dogging Wrench	1	N/A	3/16" Hex

2

Mark Door

1. Establish horizontal centerline of device by drawing line across door and stop, 40-5/16" (1.02m) above finished floor unless doors have been pre-prepped. (Figure 1)

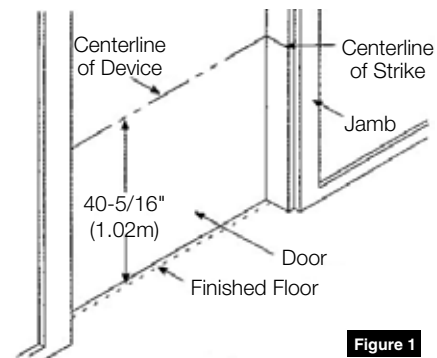

Figure 1

3

Install Trim, if furnished

See enclosed trim installation instructions.

4

Cut Pushbar, if required

NOTE: If bar does not require cutting, proceed to Section 5.

1. Installation of device depends on trim. Note 3/4" (19mm) minimum restriction. (Figure 2)

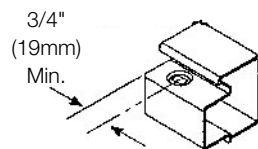

Figure 2

2. Measure and mark bar as shown. (Figure 3)
3. Fully depress bar and cut off square on mark. (Figure 4)

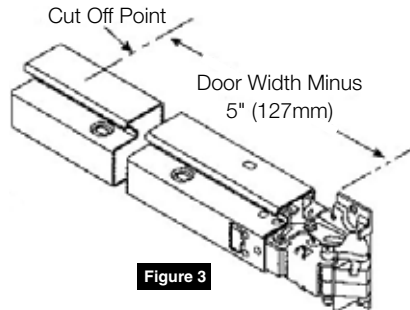

Figure 3

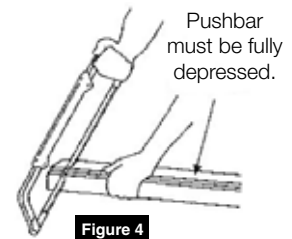

Figure 4

5

Mount ED8200 or ED8200B Exit Device

Installation of device depends on trim. (Figure 5)

1. **For Through-bolted Trim In 2-1/8" Prep**
Install device with two (2) fillister head screws (packed with trim) in latch assembly holes marked D.

For All Other Applications

Install device with two (2) PHMS, two (2) internal tooth lock washers and two (2) sex nuts in latch assembly holes marked C.

2. **For Reinforced Metal Doors**

Ensure device is level. Use rear bracket to spot, drill and tap two (2) #12-24 rear bracket mounting holes. Attach rear bracket to door using two (2) PHMS and two (2) lock washers.

For All Other Door Types

Ensure device is level. Use rear bracket to spot and drill 1/4" (6mm) holes through door. Enlarge holes 3/8" (10mm) from opposite side of door to clear for sex nuts and bolts. Attach rear bracket and backing plate to door using two (2) PHMS, two (2) lock washers and two (2) sex nuts.

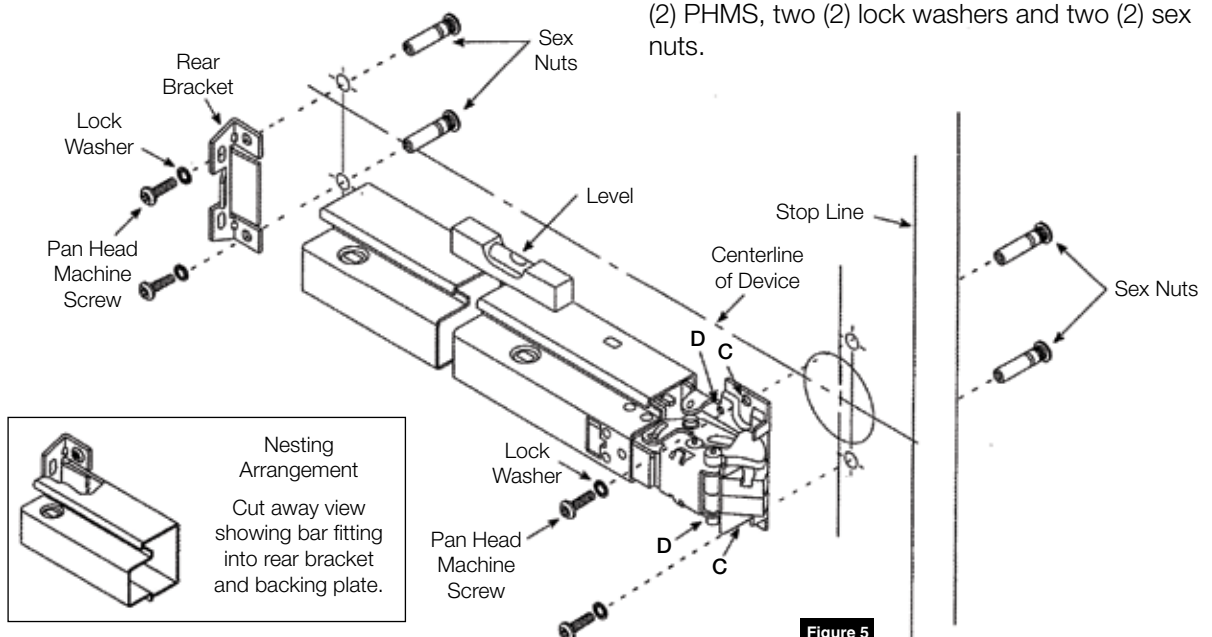

Figure 5

5

Install Strike

1. Install strike with two (2) pan head machine screws, two (2) external tooth lock washers. (Figure 6)
2. Adjust strike.
NOTE: Strike is properly adjusted when latch is able to fully project when door is closed.
3. Tighten all screws.

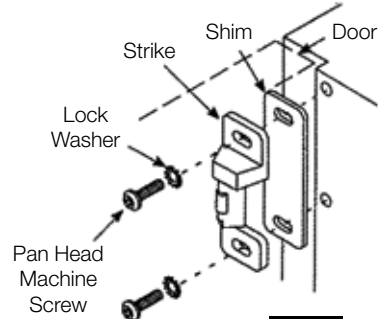

Figure 6

6

Install Front Bar Insert, Rear and Front Covers

1. Slide front bar insert over end of front bar.
2. Insert 1/2" pan head tapping screw through insert mounting hole.
3. While holding insert flush against back edge of front bar, tighten screw to bottom of recessed mounting hole.
4. Install front and rear cover using 1" flat head screw with attached washer.

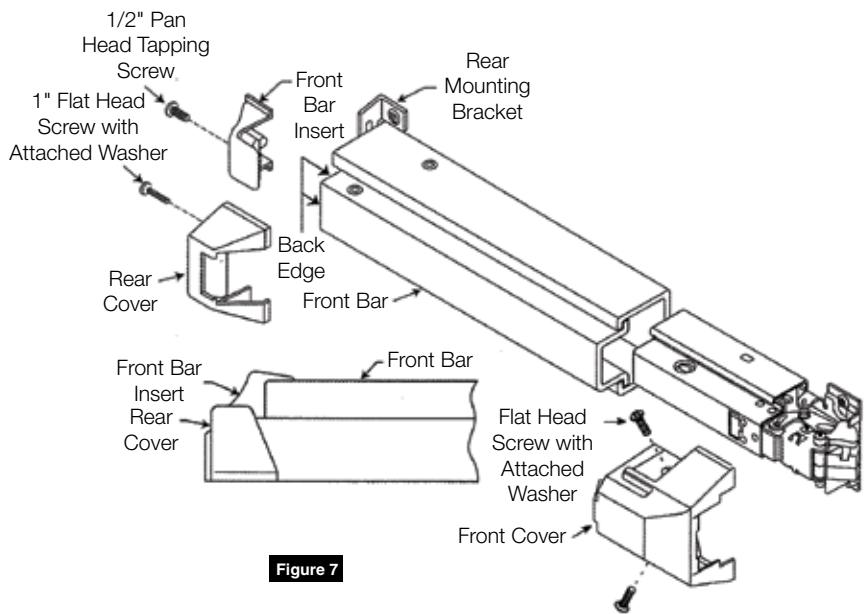

Figure 7

7

Test Pushbar

Latchbolt is retracted by pushbar inside.
If latchbolt does not operate properly or does not remain secure, inspect all mounting dimensions outlined in Sections 3-5.

Corbin Russwin
225 Episcopal Road
Berlin, CT 06037
Phone: 800-543-3658
Fax: 800-447-6714
corbinrusswin.com

ASSA ABLOY is the global leader in door opening solutions, dedicated to satisfying end-user needs for security, safety and convenience