

DOUBLE DOOR APPLICATIONS ONLY

TEMPLATE CROSS REFERENCE (For Single Door Applications)

Description	Template
ED8200A Series Rim Device	T30465

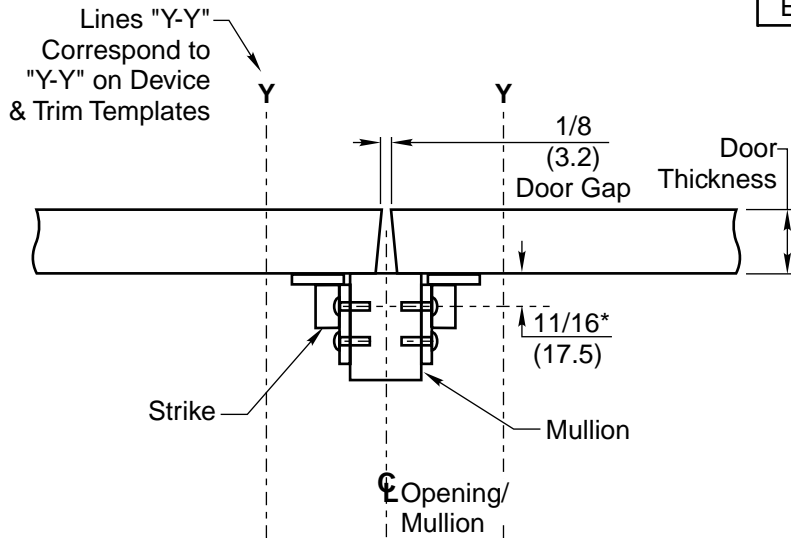

RECOMMENDED MINIMUM STILE	
Stile	Description
5-1/4 (133.4)	ED8200A Series

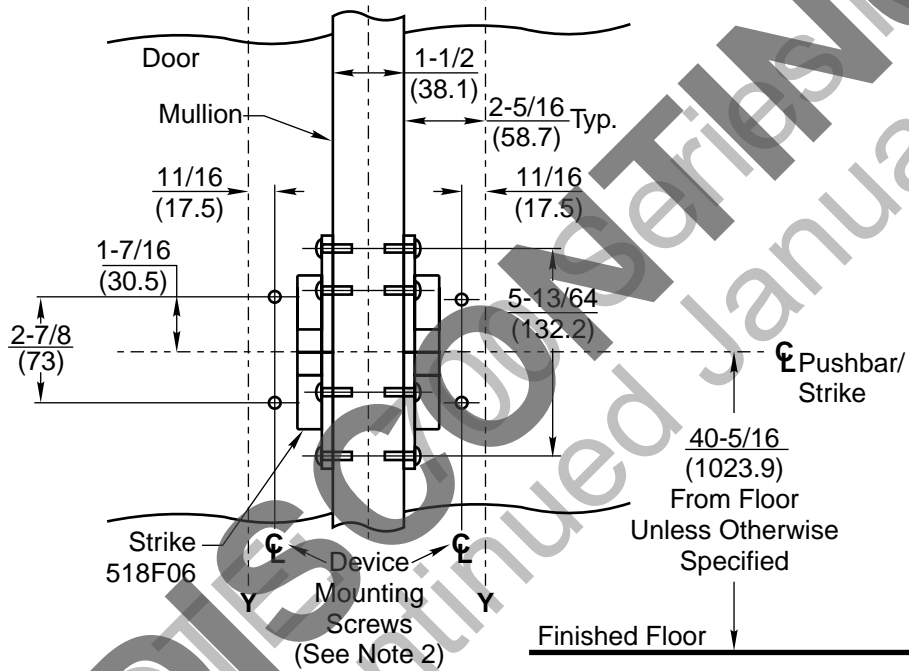

NOTES:

1. For 707A and 708A (KM) Mullion Frame Preparation Template, refer to T30882.
2. For other device and strike mounting specifications, refer to appropriate single door application template.
- *3. **Caution:** When glass bead shims are used to raise device off surface of door, refer to glass bead shim template T30494 for proper strike mounting dimensions.
4. For preparation of trim, refer to separate template.
5. Dimensions given in inches and (mm).

**ED8200A Series
Rim Fire Exit Devices
Application to Metal, Wood or Composite Doors
With 707A and 708A (KM) Mullion**



SUPERSEDES	T30941	DO NOT SCALE DRAWING
TEMPLATE NUMBER	T30941-1	DATE 10-05