

Notes:

1. This template is an addition to the device template. Locate centerlines using horizontal and vertical references on device template.
2. Do not scale drawing.
3. Dimensions are in inches (mm).
4. LHR door shown. Preparation is typical for both door hands.
5. For door reinforcement see template T30800.
6. Prepare mounting holes when installing the trim.
7. Provide adequate internal support to prevent door deformation after trim is bolted to the door.
8. At specifier's option ANSI A115.2 cutout thru door may be substituted. If type 161 stock doors are used a filler plate (by others) is required for the door edge. Dimensions given about a centerline are symmetrical.

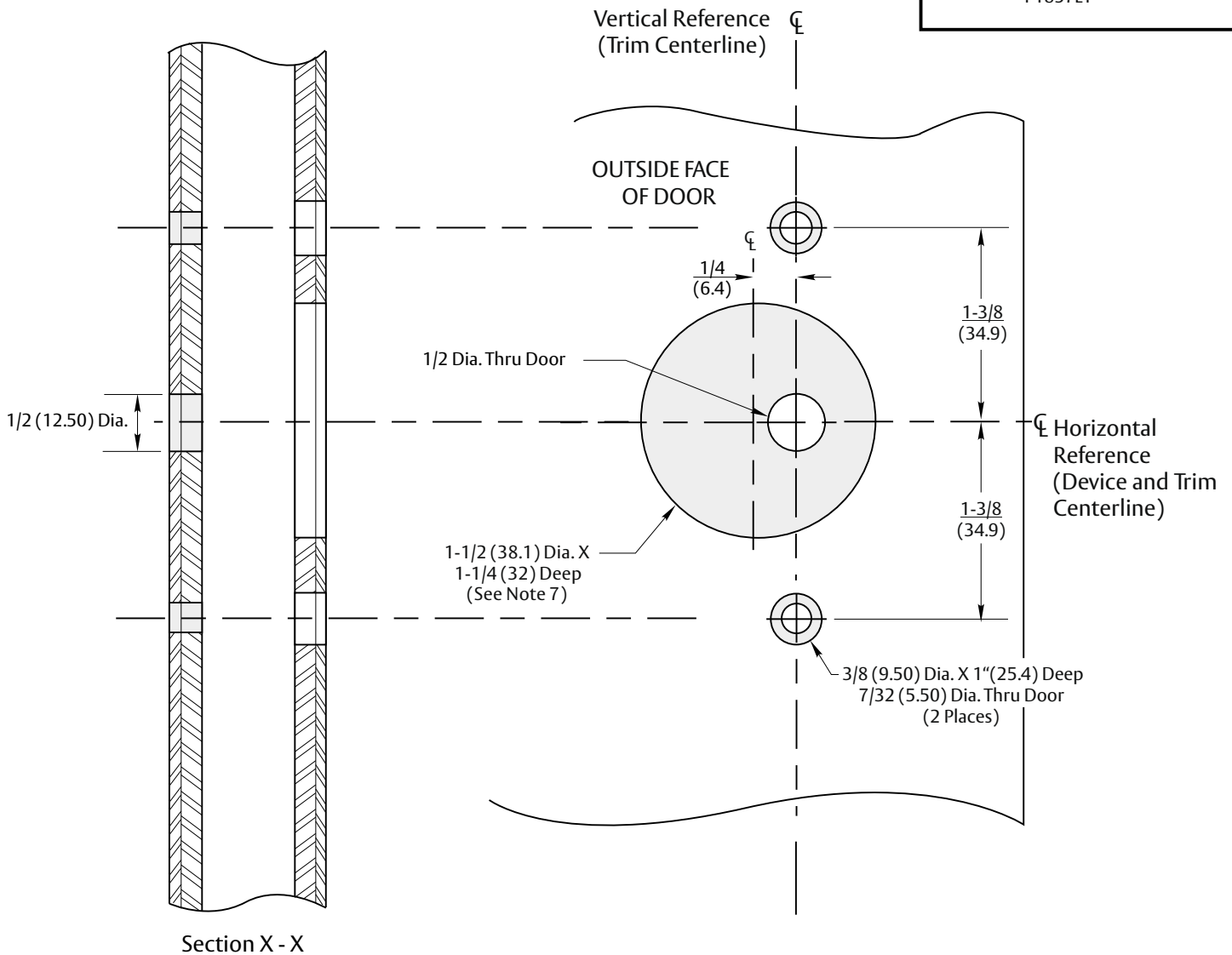
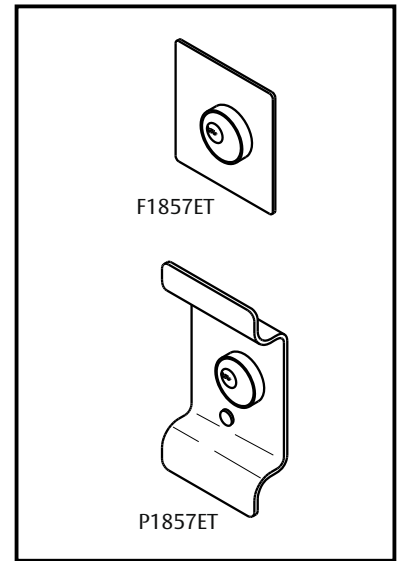

RESPONSIBILITY

DOOR AND FRAME MANUFACTURERS ARE RESPONSIBLE FOR PROVIDING ADEQUATE CONSTRUCTION OR REINFORCEMENTS FOR PROPER INSTALLATION OF HARDWARE SHOWN. ALL ARCHITECTURAL BUILDERS HARDWARE MUST BE INSTALLED ON PROPERLY REINFORCED DOORS AND FRAMES, REGARDLESS OF TYPE, MATERIAL, OR METHOD OF CONSTRUCTION.

**F1857ET and P1857ET Trim
Application for Metal Door
With ED2000 Series
Rim and Vertical Rod Exit Devices**



www.corbinruswin.com

SUPERSEDES	DO NOT SCALE DRAWING	
TEMPLATE NUMBER	SHEET	DATE
T31271	1 of 1	04/23

Experience a safer and more open world

Copyright © 2023 ASSA ABLOY Access and Egress Hardware Group, Inc. All rights reserved. Reproduction in whole or in part without the express written permission of ASSA ABLOY Access and Egress Hardware Group, Inc. is prohibited.