

ML2000 Series Mortise Lock

ASSA ABLOY

For latchbolt assemblies that contain a Locking Pin as shown in Figure 4. Locksets with this assembly shipped from the factory since 2022.

1. Move the Red locking screw to side of lock-body being locked (Figure 1)
2. Push in latch partially then depress catch plate with screwdriver (Figure 1)

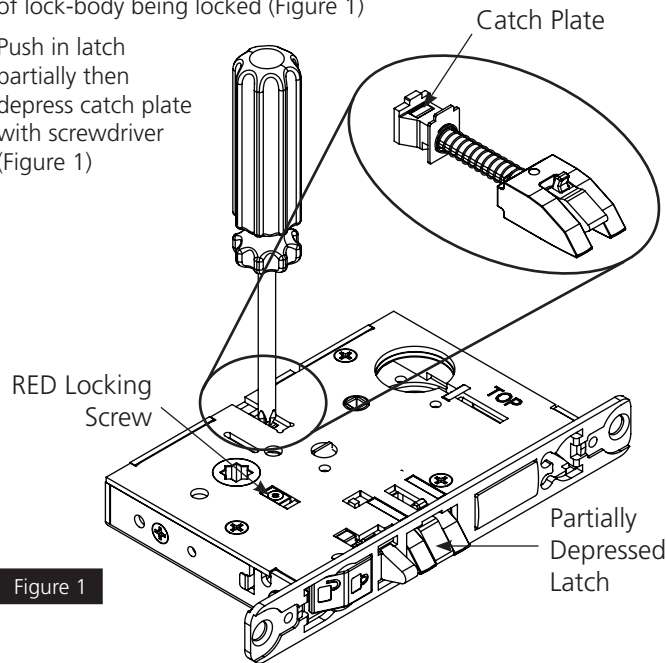

Figure 1

3. Pull latch out of lock-body and rotate 180 degrees (Figure 2)

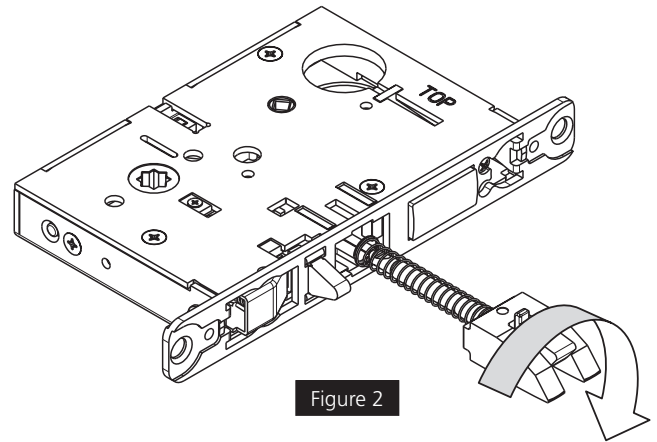
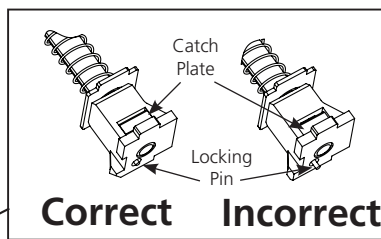

Figure 2

4. Push in latch until tail-piece hits back of case (Figure 3)

Note: Make sure catch plate is even with top surface and locking pin is not projected (Figure 4). If not, depress catch plate with screwdriver and repeat step 4.



Correct Incorrect

Figure 4

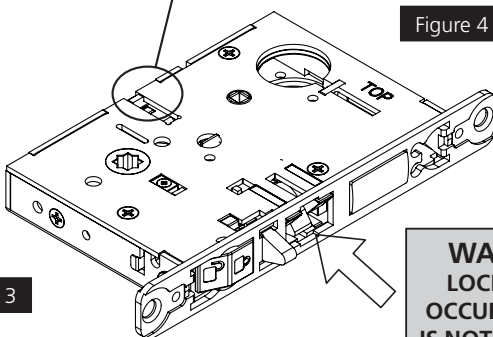

Figure 3

**WARNING:
LOCK-IN CAN
OCCUR IF LATCH
IS NOT PROPERLY
INSTALLED**

5. Rotate lock front to match level of door as shown (Figure 5)

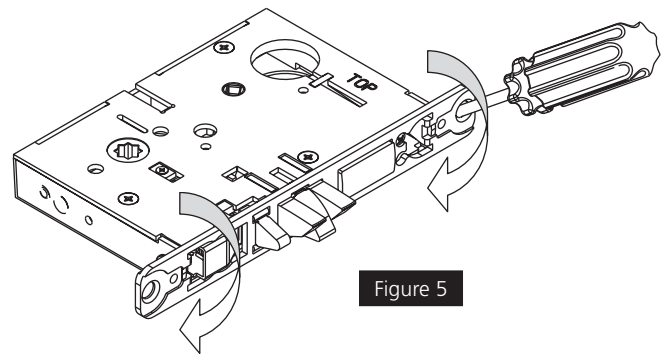

Figure 5