

Motorized Electric Latch Retraction (MELR)

With Optional M91 Bolt Monitor,
M92 Touchbar Monitor, and
M93 Trim Monitor Connection

ED4000, ED5000 Series Exit Devices

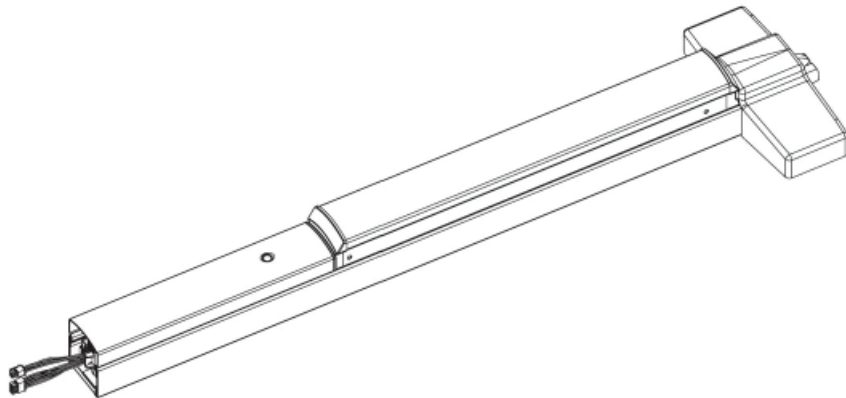

WARNING

This product can expose you to lead which is known to the state of California to cause cancer and birth defects or other reproductive harm. For more information go to www.P65warnings.ca.gov.

TOC	Table of Contents
1	Overview.....4
a	Functions.....4
b	Installation Notes.....5
c	Hinge Requirements.....5
d	Wire Gauge Chart5
e	Power and Contact Ratings5
f	Wire Cover Installation6
g	Wire Locations and Positions7
h	DIP (Dual Inline Package) Switch Settings8
i	ElectroLynx Wiring System9
2	Power Mode 10
a	Power Mode Installation..... 10
b	Power Mode Wiring 12
c	Configuration Instructions DIP Switch Settings..... 13
d	LED Signaling 13
e	Power Mode Troubleshooting 14
3	Timer Mode 15
a	Timer Mode Installation 15
b	Timer Mode Installation Wiring..... 16

Installation Instructions

TOC	Table of Contents, continued
c	Timer Mode Adjustment (Onboard Timer)..... 19
d	Configuration Instructions DIP Switch Settings..... 20
e	LED Signaling Chart..... 21
f	Timer Mode Troubleshooting..... 21
4	Optional M93 Trim Monitor Switch 23

1

Overview

The Corbin Russwin Motorized Latch Retraction (MELR), see Figure 1, works with the ED4000 and ED5000 Series exit devices to provide remote-controlled latch retraction option. It is compatible with the following:

- M91 - Bolt Monitor Switch: Provides indication of the position of the latch bolt. Used with security systems to monitor the latch bolt. Also used to activate automatic door operators upon latch retraction.
- M92 - Touchbar Monitor: Provides indication of the pushbar being depressed. Used as a request to exit to shunt alarm systems, release electromagnetic locks or monitor egress.
- M93 - Trim Monitor Switch: Provides indication of the device being operated from the outside. Used as a request to enter signal switch to shunt alarms. Also used to monitor entry.

NOTE: The MELR option is also compatible with hex key, cylinder key and fire rated mechanical configurations.

a

Functions

The MELR option can be configured to work in either of two modes:

- Power Mode (See Section 2, Page 10): The device is not energized when locked. When power is applied, the pushbar and latch(es) will retract and remain in the retracted position until power is removed. Power is typically applied through a relay triggered by an access control device.
- Timer Mode (See Section 3, Page 15): The device is always energized and retraction is triggered by a momentary or maintain switch.

— When the timer circuit is closed using a **momentary** switch, the device retracts, remains retracted for a set duration, and releases. The duration of the retraction is set through an onboard timer setting.

— When the timer circuit is closed using a **maintain** switch, the device retracts. The device releases when the contact is opened.

Caution:

Disconnect all input power before servicing.

- Installer must be a trained and experienced service person.
- Wiring must comply with applicable local electrical codes, ordinances and regulations.
- Hex key or cylinder (M52) mechanical dogging CANNOT be used on Fire Rated Doors.

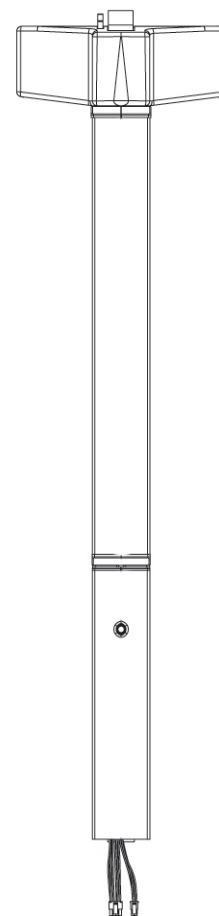

Figure 1 MELR

Installation Instructions

1 Overview, continued

b Installation Notes

- The MELR option pushbar works only with Corbin Russwin ED4000 and ED5000 Series exit devices.
- Always perform mechanical installation using the appropriate installation instructions, prior to electrical wiring.
- Earth Ground: Required for electrostatic discharge (ESD) protection, unless grounded through the metal door and frame.

c Hinge Requirements

Hinge Information				
Without Timer			With Timer	
Application	Wires	Recommended Hinge	Wires	Recommended Hinge
MELR	3	QC8	5	QC12
M91 MELR	5	QC8	7	QC12
M92 MELR	6	QC8	8	QC12
M91, M92 MELR	8	QC8	10	QC12
M93 MELR	5	QC12	7	QC12
M91, M93 MELR	7	QC12	9	QC12
M92, M93 MELR	8	QC12	10	QC12
M91, M92, M93 MELR	10	QC12	12	QC12

d Wire Gauge Chart

Wire Gauge Information								
Total One-Way Length of Wire Run (ft.)	Load Current @ 24VDC							
	1/4A	1/2A	3/4A	*1A	1-1/4A	1-1/2A	2A	3A
100	24	20	18	18	16	16	14	12
150	22	18	16	16	14	14	12	10
200	20	18	16	14	14	12	12	10
250	18	16	14	14	12	12	12	10
300	18	16	14	12	12	12	10	-
400	18	14	12	12	10	10	-	-
500	16	14	12	10	10	-	-	-
750	14	12	10	10	-	-	-	-
1,000	14	10	10	-	-	-	-	-
1,500	12	10	-	-	-	-	-	-

*When calculating voltage drop, use 1A as the recommended current draw for the MELR

e Power and Contact Ratings

MELR Contact Ratings

Voltage: 24VDC

- Filtered and regulated power supply
- Motor operating current: 600mA
- Motor hold current: 250mA

Contact Ratings		
M91 Latch Bolt	M92 Touch Bar	M93 Trim
200mA28VDC	1A@30VDC	1A@28VDC

1

Overview, continued

f

Wire Cover Installation

1. While holding motor harness, slide wire cover all the way into the device assembly.

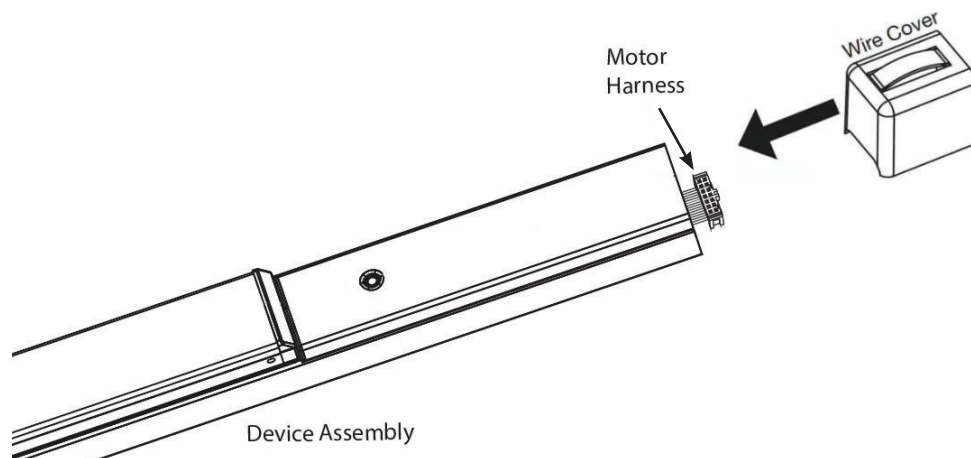

Figure 2 Installing Wire Cover

2. Plug motor harness into controller.

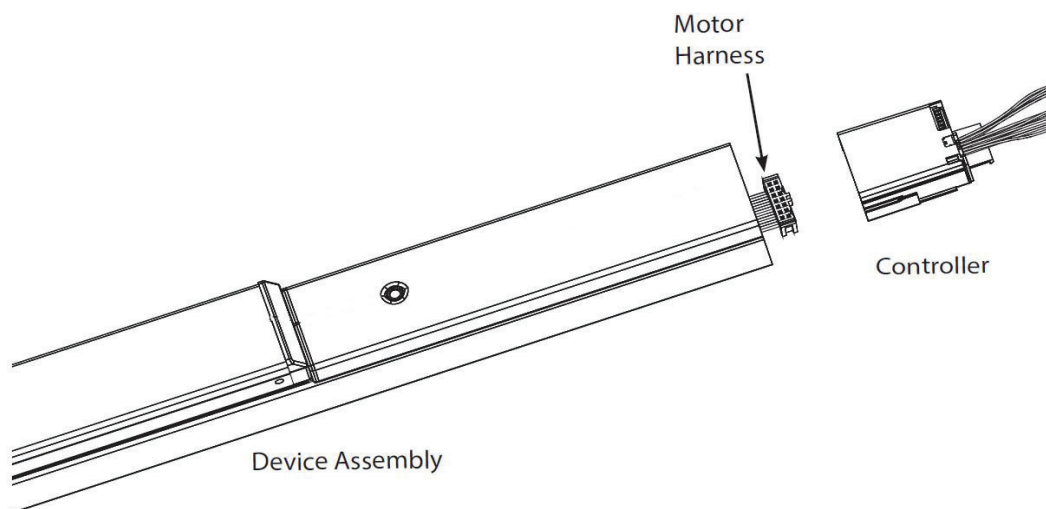

Figure 3 Connecting Motor Harness

Installation Instructions

1 Overview, continued

f Wire Cover Installation, continued

3. Slide controller into touch bar, making sure tab is securely attached over end of chassis.

Figure 4 Tab attachment

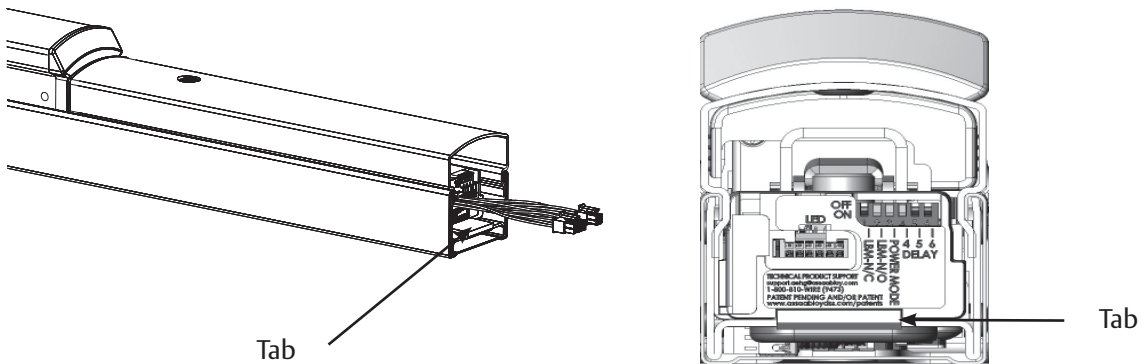

g Wire Locations and Positions

MELR option devices are supplied with one (1) 4-pin and one (1) 8-pin Molex® connector (See Figure 5). Molex connectors allow simple installation using the ASSA ABLOY ElectroLynx® system.

Figure 5 Wire Color and Position

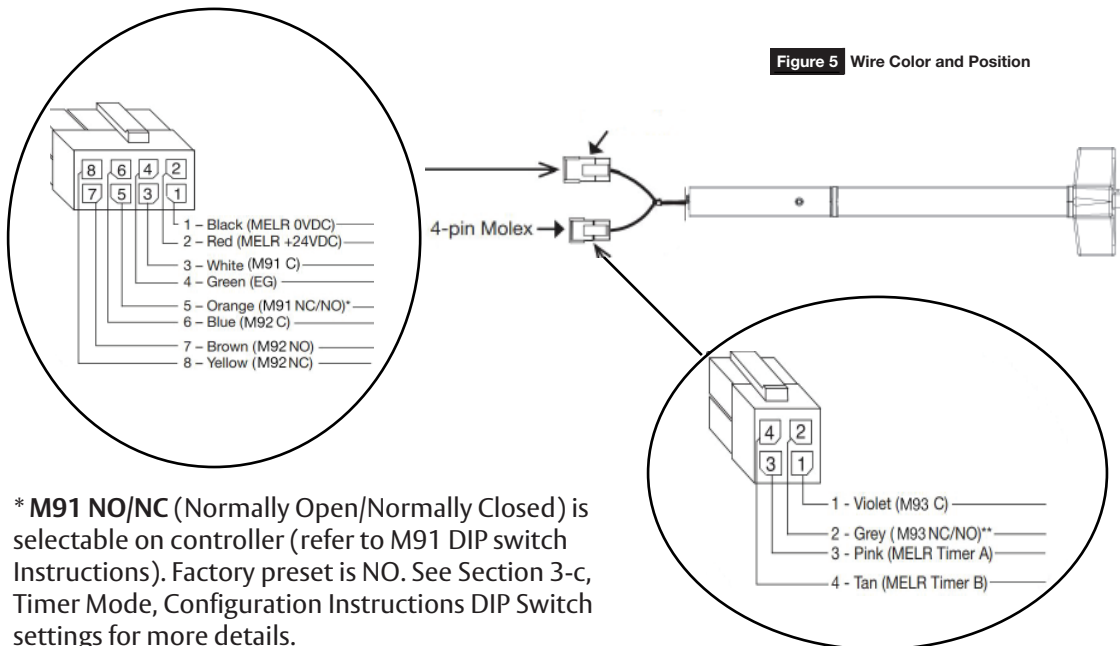

* **M91 NO/NC** (Normally Open/Normally Closed) is selectable on controller (refer to M91 DIP switch Instructions). Factory preset is NO. See Section 3-c, Timer Mode, Configuration Instructions DIP Switch settings for more details.

** **M93 NO/NC** (Normally Open/Normally Closed) is selectable on controller. Factory preset is NO. See Section 4 Optional M93 Trim Monitor Switch for details.

1

Overview, continued

h

DIP (Dual Inline Package) Switch Settings

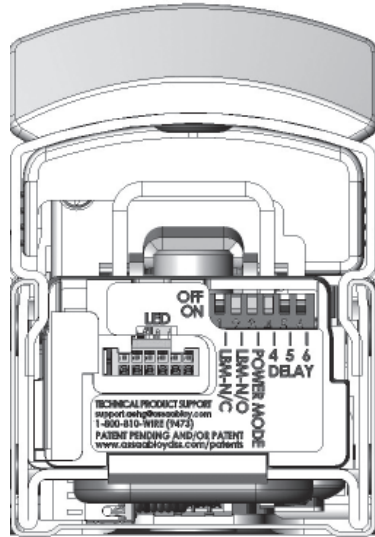
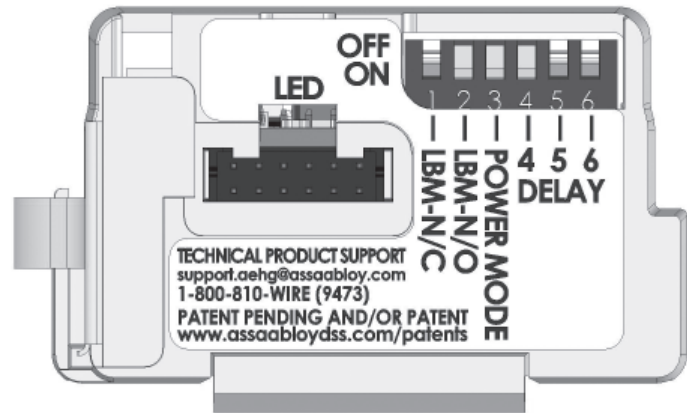

Figure 6 DIP Switch Settings (Factory Default Shown)



DIP Switch assignments are as follows, starting from left in Figure 6:

a. Closed (Switch #1 set to **ON**) when selecting **LBM/NC (Normally Closed)** contact.

Or

b. Closed (Switch #2 set to **ON**) when selecting **LBM/NO (Normally Open)** contact.

Note:

- Only 1 or 2 should be closed at one time, not both.
- 3: Closed when bypassing external trigger, i.e. Power Mode.
- 4,5,6: Select software options, allows up to 8 Time/Delay settings (See Section 3 Timer Mode).
- Default Setting: LBM/NO and Power Mode set to ON.

1

Overview, continued

i

ElectroLynx Wiring System

Important:

Do Not Force - ElectroLynx connectors plug and lock together in only one way. See Figures 7 & 8.

Figure 7 ElectroLynx Connections

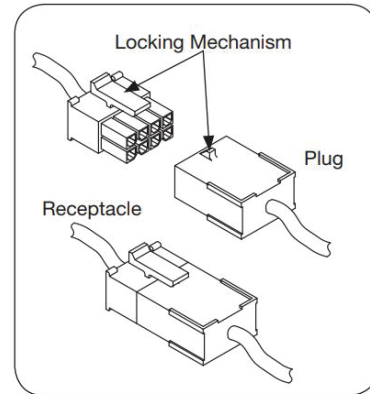
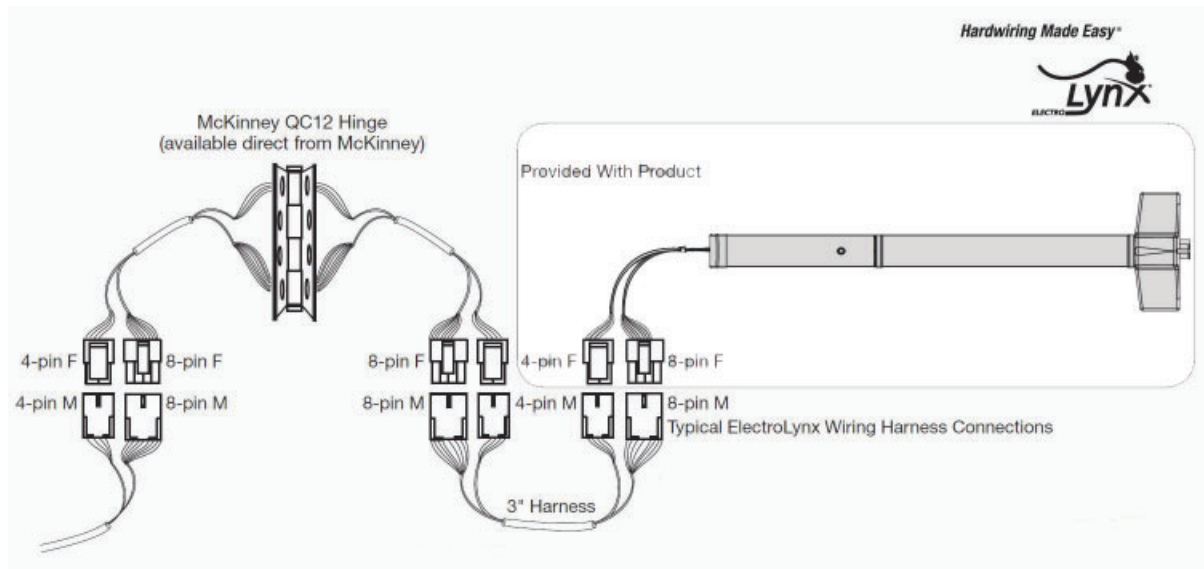

Figure 8 Typical ElectroLynx Wiring



NOTE:

- Devices ordered with M91, M92, M93 and MELR Options wired in Timer Mode require all 12 wires.
- The 3" Harness is not included with the product, door or hinge and must be ordered separately.

2

Power Mode

a

Power Mode Installation Instructions

In this configuration, the device is not energized when locked. When energized with a 24 volt input, the pushbar and latch(es) will retract and remain in the retracted position until power is removed. Power is typically applied through a relay triggered by an access control device. For installations using the onboard timer circuit, refer to Section 3 Timer Mode.

Rail retracts when power is applied and releases when power is removed.

1. Mount ED4000 or ED5000 Series exit device using mechanical installation instruction sheet(s) provided.

NOTE:

- Ensure proper mechanical function before attempting electrical retraction:
- Verify the pushbar can be fully depressed and the latch is fully retracted.
- On vertical rod devices, verify latch bolts do not enter hold-back position until pushbar is fully depressed.
- Adjust device mechanically as required, before applying power.

2. Connect the ElectroLynx harness in the door. See Figure 9.

Figure 9 Typical ElectroLynx Power Mode Wiring

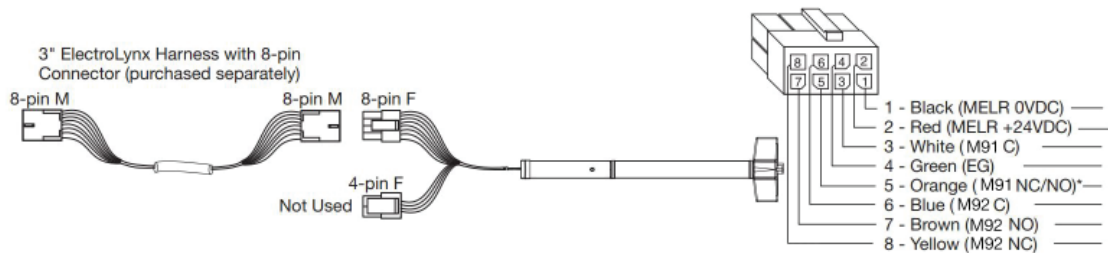

* M91 NO/NC (Normally Open/Normally Closed) is selectable on controller (refer to M91 DIP switch instructions in Section 3). Factory present is NO.

3. Plug the 8-pin ElectroLynx connector from the pushbar into the 3" ElectroLynx harness or splice into non-ElectroLynx harness. See Figure 10.

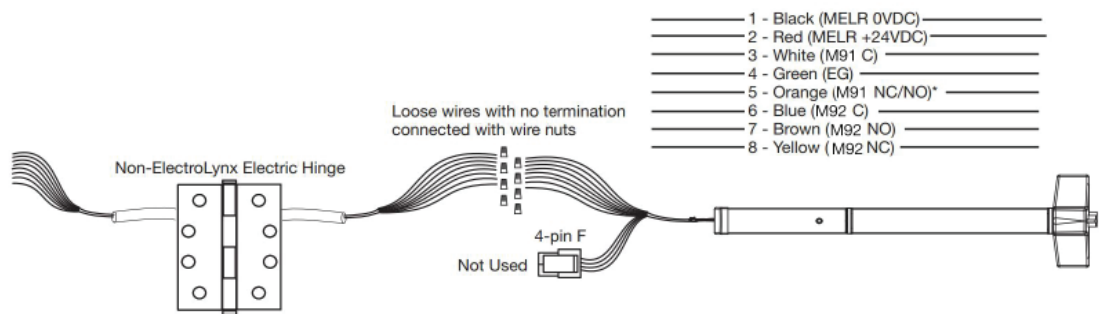

Figure 10 Non-ElectroLynx Power Mode Wiring MELR Wires with ElectroLynx Connector Removed

Installation Instructions

2 Power Mode, continued

a Power Mode Installation Instructions, continued

4. Feed the 3" harness through the 1" hole in the door and secure the pushbar to the door using the mounting bracket and two (2) supplied screws (Figure 11).

NOTE:

- Do not install the end cap until electrical operation is verified in order to confirm LED signaling.
- Do not discard the end cap and hardware.

5. Ensure DIP switch (position 3) enables Power Mode (Figure 12)

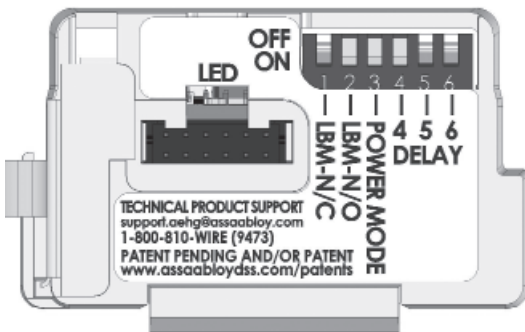

Figure 12 DIP Switch Setting for Power Mode Installation

6. Connect the ElectroLynx harness to the hinge and secure the hinge to the door.

NOTE:

- Make sure no wires are pinched or damaged in the process.
- Refer to detailed wiring instructions under Power Mode wiring.

7. Apply a 24V source which complies with the Content Ratings table MELR contact ratings. Confirm the LED is blinking, the system fully unlocks and all bolts clear the strikes. Troubleshoot the device if issues are observed using the steps outlined at the end of this section.

8. Store excess wiring under end cap and assemble with provided screws. Avoid pinching wires.

NOTE:

Earth Ground is required for Electrostatic Discharge (ESD) protection unless the metal door and frame are already earth grounded; otherwise, earth ground wiring is required at pin 4. See Figure 9.

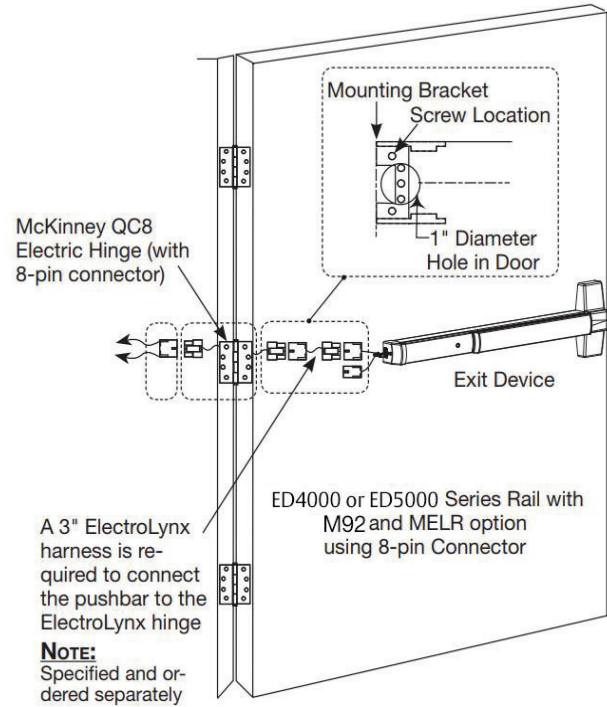

Figure 11 Power Mode Installation

2 Power Mode, continued

b Power Mode Wiring

ElectroLynx Opening Installation

This is the simplest installation method, requiring the installer to plug the ElectroLynx connectors from the exit device to the harness to the hinge and then to the pigtail, which is connected to the access control system.

Requirements:

- MELR Exit Device
- 3" ElectroLynx connector harness (not supplied with MELR option)
- McKinney QC ElectroLynx hinge (type of hinge depends on the application)
- ElectroLynx door

Non-ElectroLynx Opening Installation

Standard door with standard electric hinge. Molex connectors with flying leads purchased separately (See Figure 13 and the Molex Connectors Table).

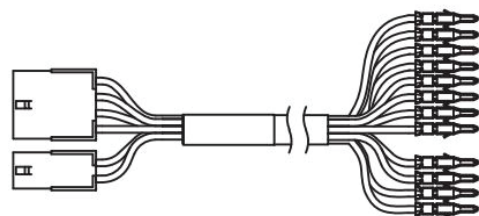

Figure 13 Molex with 12-Pin Connector Pinned

Molex Connectors		
Size	Both Ends	To PINS
3 Inch	QC-C003	QC9C003P
6 Inch	QC-C006	QC9C006P
12 Inch	QC-C012	QC9C012P

To identify part numbers and order harness(es), visit the McKinney website, www.mckinneyhinge.com, and search the catalog for ElectroLynx.

If Molex pinned connectors are not available, remove the ElectroLynx connector from the MELR Exit Device and wire nut the MELR wires to the wires from the electric hinge (color coordinating wire colors is recommended).

Power Mode Wiring

Use when wiring in Power Mode. See Figure 14.

NOTE:

- Onboard timer will not function in Power Mode. Add external time delay, if necessary.
- The switch is wired between the power supply and the load. Do not cycle the power supply.

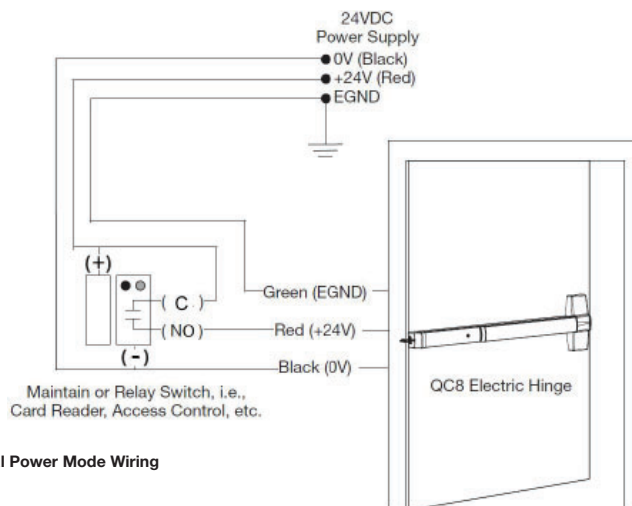

Figure 14 MELR ED4000 and ED5000 Series Exit Device Typical Power Mode Wiring

Installation Instructions

2 Power Mode, continued

c Configuration Instructions DIP Switch Settings (M91)

For MELR applications using the optional M91 latch bolt monitor switch, pin 5 of the 8-pin ElectroLynx connector will be either a NO contact or NC contact, depending on the position of the DIP switches on the motor controller faceplate (Figure 15).

Figure 15 Molex with 12-Pin Connector Pinned

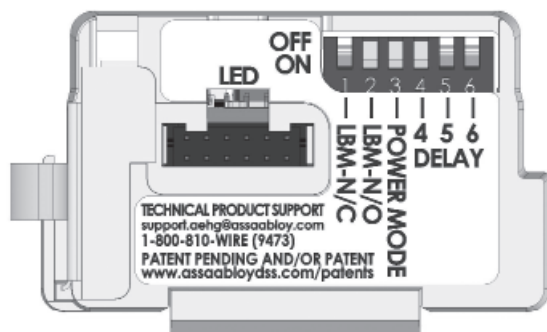

DIP Switch Setting for M91 Latch Bolt Monitoring
NO (Default) Shown

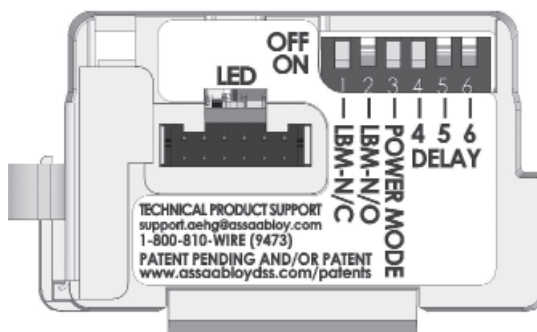
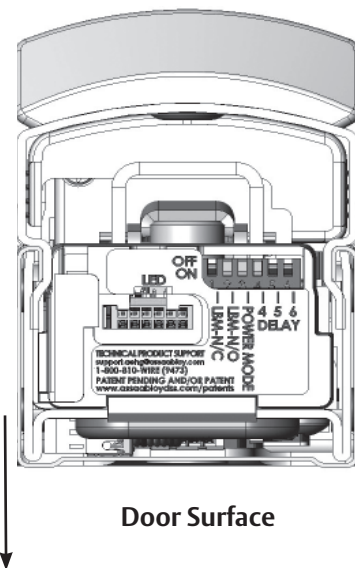

NC Alternative DIP Switch Setting

d LED Signaling

Signal	Cause	Troubleshooting
Dark / Unlit	Controller microprocessor is not active	Confirm connections and incoming power
Steady Flashing	Normal operation	Check that Power Mode switch is set
Solid Light	Input voltage is dropping out of operating range	Check wire run and power supply output
2 Flashes Followed by Pause	Retractor sensor problem	Call 1-800-810-WIRE (9473) for assistance

2

Power Mode, continued

e

Power Mode Troubleshooting

Prior to electrical troubleshooting, confirm that the mechanical system properly functions; i.e., that the pushbar fully retracts all latches and the door opens freely. See the table on page 14. Refer to applicable Corbin Russwin ED4000 and ED5000 Series Exit Device product instruction sheet to correct mechanical installation issues.

IMPORTANT:

* ALWAYS disconnect power before making any mechanical adjustments to the system.

Table 6 – Power Mode Troubleshooting
<p>The pushbar does not move when 24V input is applied:</p> <ul style="list-style-type: none"> • Check inputs to confirm proper voltage and wiring orientation (Figure 6 ElectroLynx Power Mode Installation). • Remove end cap from pushbar and confirm that LED is blinking steadily when power is applied. If not, refer to LED signaling. <p>NOTE: When configured in Power Mode, power is released to lock the device (LED will not blink when power is released).</p> <ul style="list-style-type: none"> • Confirm DIP switch position 3 is set to ON.
<p>The pushbar does not fully retract or pushbar retracts completely and holds but does not open door:</p> <ul style="list-style-type: none"> • * Verify mechanical installation and correct as necessary: <ul style="list-style-type: none"> – Is excessive force required to depress the pushbar? – Are latches fully clearing the strikes when mechanically cycled?
<p>The pushbar retracts and unlocks electrically but does not relock:</p> <ul style="list-style-type: none"> • Physically disconnect power from pushbar and confirm that input is off. • * Check for mechanical interference (e.g., warped door, lack of shims, misalignment of pushbar, etc.).
<p>Rail behaves abnormally (multiple cycles, clicking, delayed retraction, etc.):</p> <ul style="list-style-type: none"> • Remove end cap from pushbar and confirm that LED is blinking steadily when power is applied. If not, refer to LED signaling. <p>NOTE: When configured in Power Mode, power is released to lock the device (LED will not blink when power is released).</p>
<p>For applications using automatic operator(s): Door(s) fail to unlock before doors begin to open:</p> <ul style="list-style-type: none"> • Adjust timing of operator to allow 900ms for the pushbar to fully retract.
<p>M91 switch wiring: The design requires normally open functionality and the circuit is normally closed (or vice versa),</p> <p>There is only a two-wire input for the M91 circuit. Normally open or normally closed configuration is set by toggling the DIP switches on the controller bracket to the required position</p>
<p>For additional installation assistance, please contact 1-800-810-WIRE (9473). When calling, please provide the following information to improve our service (provide what you can):</p> <ul style="list-style-type: none"> • Your name and contact number. • ED4000 and ED5000 Series Exit Device product type with options. • Location and identification of the affected opening (e.g., site, building, and door number). • Yale Commercial order number (located on product box), if available. • Power supply manufacturer and rated output (i.e., voltage and current). • Method of operation (e.g., Power Mode). • The number of devices connected to the power supply. • Symptoms of problem (i.e., observed behavior).

Installation Instructions

3

Timer Mode

a

Timer Mode Installation Instructions

In this configuration, the device is always energized with a 24 volt input, and a timer circuit is opened or closed to control pushbar retraction. A momentary or maintain switch is typically used to perform this operation. For installations where the power input is cycled to retract the device, refer to Section 2: Power Mode.

1. Rail retracts when timer input is closed. Mount ED4000 or ED5000 Series exit device using mechanical installation instruction sheet(s) provided.

Note:

Ensure proper mechanical function before attempting electrical retraction:

- Verify the pushbar can be fully depressed and the latch is fully retracted.
- On vertical rod exit devices, verify that the latch bolts do not enter hold-back position until the pushbar is fully depressed.
- Adjust device mechanically, as required, before applying power.

2. Ensure DIP Switch (position 3) disables Power Mode (Figure 16). Set to OFF to disable.

3. Connect the ElectroLynx harness in the door (Figure 17).

4. Plug the 8-pin and 4-pin ElectroLynx connectors from the pushbar into the 3" ElectroLynx harness or splice into a non-ElectroLynx harness.

5. Feed the 3" harness through the 1" hole in the door and secure the pushbar to the door using the mounting bracket and two (2) supplied screws.

Note:

Do not install the end cap until electrical operation is verified in order to confirm LED signaling.

Do not discard the end cap and hardware.

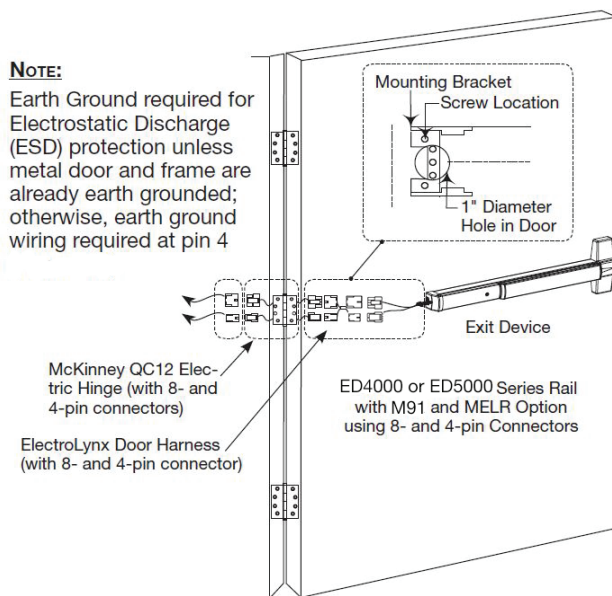
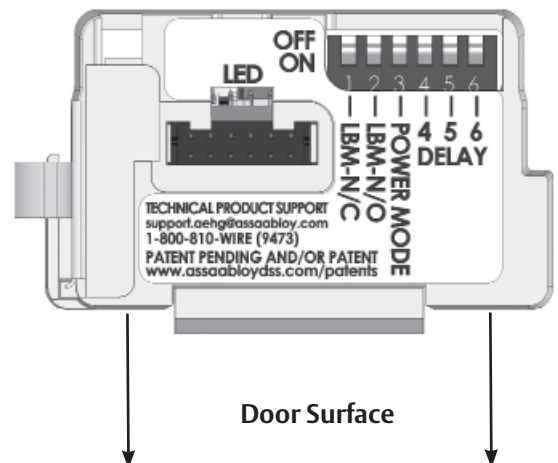

Figure 17 Timer Mode Installation

Figure 16 DIP Switch Setting for Timer Mode Installation



3 **Timer Mode, continued**

a **Timer Mode Installation Instructions, continued**

6. Connect the ElectroLynx harness to the hinge.
7. Plug the door harness's 8-pin and 4-pin connectors into the hinge's ElectroLynx connector.
8. Secure the electric hinge to door.

Note:

Make sure no wires are pinched or damaged in the process.

Refer to detailed wiring instructions under Timer Mode wiring.

9. Apply 24V according to MELR contact ratings: Confirm that the LED is blinking and close the timer input circuit to retract the device. When the system retracts electrically, confirm that it fully unlocks and that all bolts clear the strikes. Troubleshoot the device if issues are observed using the steps outlined at the end of this section.

10. Store excess wiring under end cap and assemble with provided screws. Avoid pinching wires.

b **Timer Mode Wiring**

ElectroLynx Opening Installation

This is the simplest installation method, requiring the installer to plug the ElectroLynx connectors from the exit device to the harness to the hinge and then to the pigtail, which is connected to the access control system. See Figure 18 on the next page.

Requirements:

- MELR Exit Device
- 3" ElectroLynx connector harness (not supplied with MELR option)
- McKinney QC ElectroLynx hinge (type of hinge depends on the application)
- ElectroLynx door

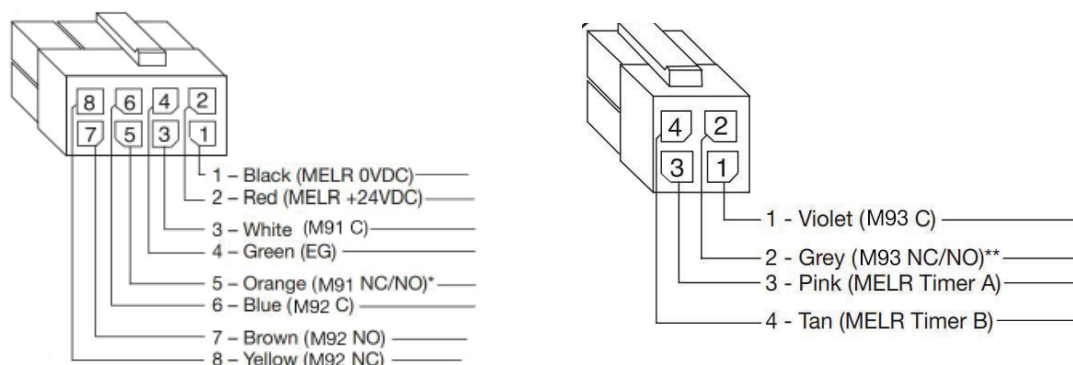

* M91 NO/NC (Normally Open/Normally Closed) is selectable on controller (refer to M91 DIP switch instructions in Section 3). Factory present is NO.

** M93 NO/NC (Normally Open/Normally Closed) is selectable on controller. Factory present is NO. See Section 4 Optional M93 Trim Monitor Switch for details if NC is preferred.

3 Timer Mode, continued

b Timer Mode Wiring, continued

Figure 18 Timer Mode Installation

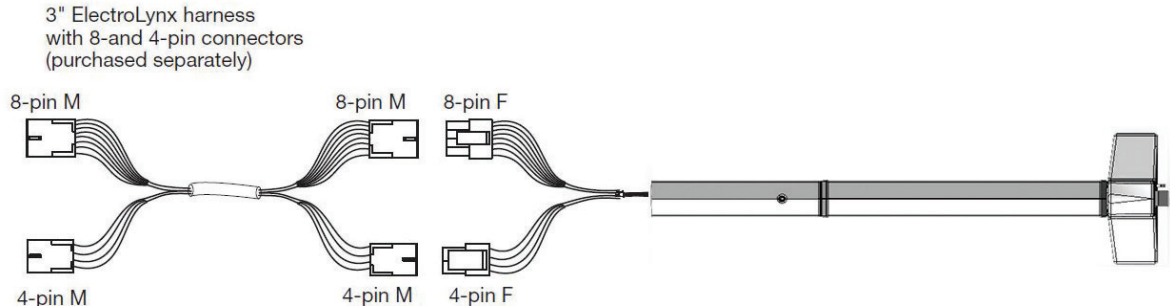

Non-ElectroLynx Opening Installation

Standard door with standard electric hinge: Remove the Electrolynx connector from the MELR Exit Device and wire nut the MELR wires to the wires from the electric hinge. Color coordinating the wires is recommended.

Molex Connectors		
Size	Both Ends	To PINS
3 Inch	QC-C003	QC9C003P
6 Inch	QC-C006	QC9C006P
12 Inch	QC-C012	QC9C012P

- 1 - Black (MELR 0VDC)
- 2 - Red (MELR +24VDC)
- 3 - White (M91 C)
- 4 - Green (EG)
- 5 - Orange (M91 NC/NO)*
- 6 - Blue (M92 C)
- 7 - Brown (M92 NO)
- 8 - Yellow (M92 NC)

To identify part numbers and order harness(es), visit the McKinney website, www.mckinneyhinge.com, and search the catalog for ElectroLynx.

* M91 NO/NC (Normally Open/Normally Closed) is selectable on controller (refer to M91 DIP switch instructions in Section 3). Factory present is NO.

3 Timer Mode, continued

b Timer Mode Wiring, continued

Timer Mode Typical Wiring

For use when wiring in Timer Mode (Figure 19) using the onboard timer. If more than 20 seconds timed delay is necessary, an external timer delay relay is required (not provided).

Note:

- 24V supply is constant in Timer Mode.
- Refer to settings in SECTION 3 Configuration Instructions DIP Switch Settings.

Figure 19 Timer Mode Typical Wiring

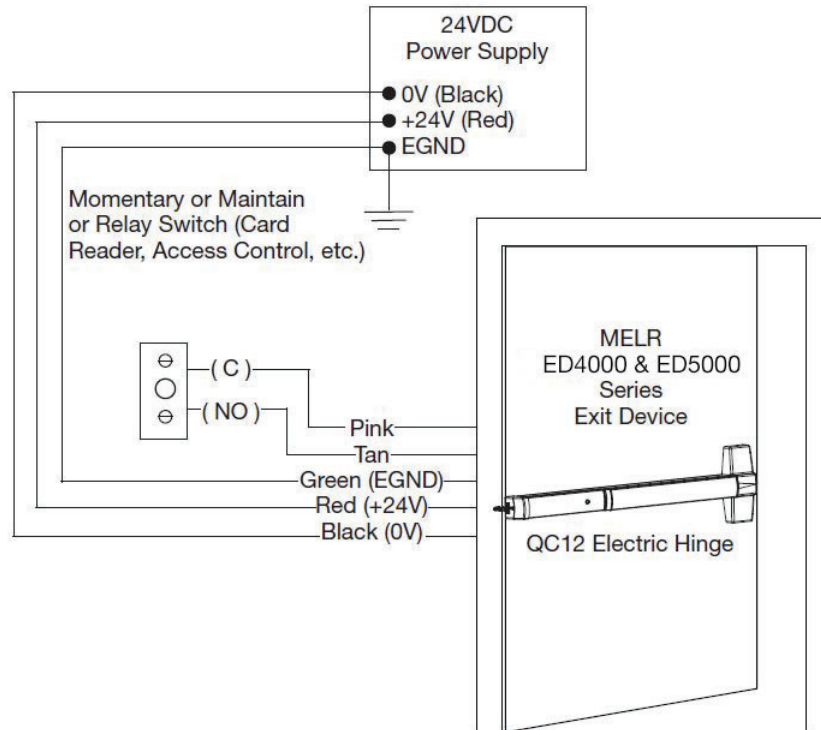
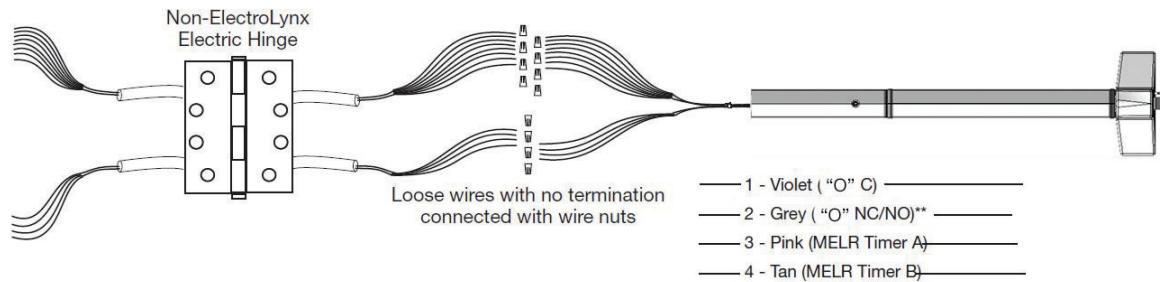

Figure 20 Non-ElectroLynx Timer Mode Connection MELR Wires with ElectroLynx Connector Removed

3

Timer Mode, continued

c

Timer Mode Adjustment (Onboard Timer)

The 24 volt input is always energized and the system retracts when the timer input circuit is closed.

- When the timer circuit is closed utilizing a momentary switch, the device retracts, remains retracted for a set duration, and releases. The duration of retraction is set using an onboard timer setting (0 – 20 second timer adjustment). The countdown begins when the pushbar is first retracted.
- The device retracts when timer circuit is closed using a maintain switch and releases when circuit is reopened.

Note:

- 24V supply is constant in Timer Mode. The duration of retraction is determined by whichever is longer: the maintain switch closure or the onboard timer delay.
- If more than a 20 second delay is necessary (exceeding the maximum setting), an external timer delay relay is required (not provided).
- Refer to settings in Figure 21 for DIP Switch timer delay settings.

3 Timer Mode, continued

d Configuration Instructions DIP Switch Settings (for M91 and timer duration)

For MELR applications using the optional M91 latch bolt monitor switch (M91 MELR), pin 5 of 8-pin ElectroLynx connector will be either NO or NC contact depending on position of the DIP switches on motor controller faceplate.

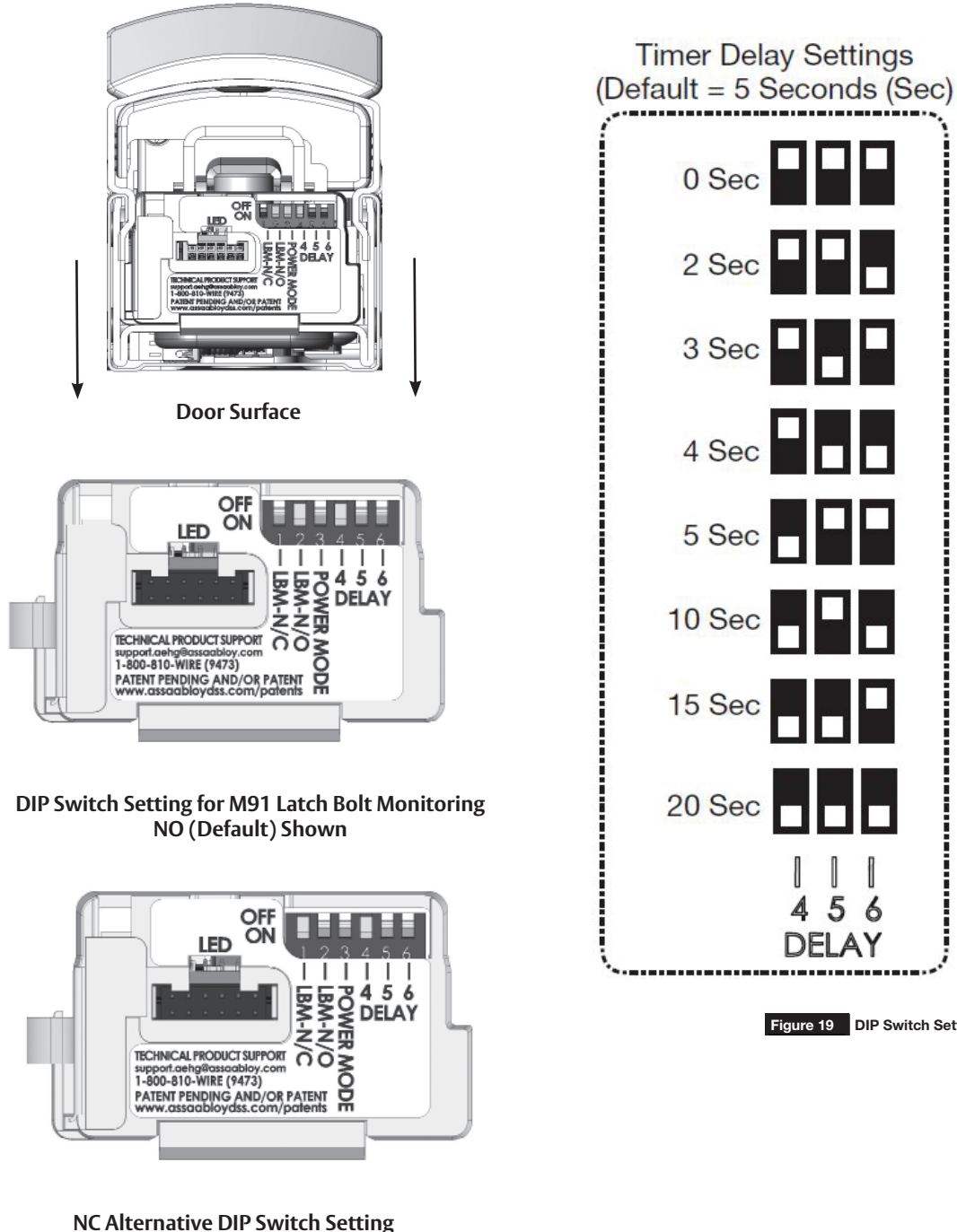

Figure 19 DIP Switch Settings

3

Timer Mode, continued

e

LED Signaling Chart

Signal	Cause	Troubleshooting
Dark / Unlit	Controller microprocessor is not active	Confirm connections and incoming power
Steady Flashing	Normal operation	Cycle device by closing the timer circuit
Solid Light	Input voltage is dropping out of operating range	Check wire run and power supply output
2 Flashes Followed by Pause	Retractor sensor problem	Call 1-800-810-WIRE (9473) for assistance

f

Timer Mode Troubleshooting

Prior to electrical troubleshooting, confirm that the mechanical system properly functions; i.e., that the pushbar fully retracts all latches and the door opens freely. Refer to applicable Corbin Russwin ED4000 or ED5000 Series Exit Device product instruction sheet to correct mechanical* installation issues.

IMPORTANT:

* ALWAYS disconnect power before making any mechanical adjustments to the system.

<p>The pushbar does not move when 24V input is applied:</p> <ul style="list-style-type: none"> • Check inputs to confirm proper voltage and wiring orientation. When configured for Timer Mode, 24V must be constantly applied and the timer circuit must be closed to cycle the device. • Remove end cap from pushbar and confirm that LED is blinking steadily when power is applied. If not, refer to LED signaling.
<p>The onboard timer duration adjustment is not working:</p> <ul style="list-style-type: none"> • Remove power when making adjustments to timer delay settings (DIP Switches). • When a momentary signal is applied to timer circuit, circuit must be reopened for timer to function.
<p>The pushbar does not fully retract or pushbar retracts completely and holds, but does not open door:</p> <ul style="list-style-type: none"> • * Verify mechanical installation and correct as necessary: <ul style="list-style-type: none"> – Is excessive force required to depress the pushbar? – Are latches fully clearing the strikes when mechanically cycled?
<p>The pushbar retracts electrically but does not release. System does not relock:</p> <ul style="list-style-type: none"> • Confirm that Timer Mode contact is opened (the pushbar will remain depressed until contact is opened and delay has expired). • Physically disconnect power from pushbar (while electrically retracted) to verify if issue is mechanical. • * Check for mechanical interference (e.g., warped door, lack of shims, misalignment of pushbar, etc.).
<p>Rail behaves abnormally (multiple cycles, clicking, delayed retraction, etc.):</p> <ul style="list-style-type: none"> • If a momentary contact is applied to timer circuit, adjust onboard timer to a longer duration. • Remove end cap from pushbar and confirm that LED is blinking steadily when power is applied. If not, refer to LED signaling.

3

Timer Mode, continued

f

Timer Mode Troubleshooting, continued

For applications using automatic operator(s): Door(s) fail to unlock before doors begin to open:

- Adjust timing of operator to allow 900ms for the pushbar to fully retract.
- If a momentary contact is applied to the timer circuit, adjust the onboard timer to a longer duration to prevent the device from locking prior to operator actuation.

M91 switch wiring: The design requires normally open functionality and the circuit is normally closed (or vice versa):

- There is only a two-wire input for the M91 circuit. Normally open or normally closed configuration is set by toggling the DIP switches on the controller racket to the required position (Figure 19).

If further assistance is required call 1-800-810-WIRE (9473) and for optimum support provide as much of the following information as possible:

- Your name and contact number.
- Corbin Russwin ED4000 and ED5000 product type with options.
- Location and identification of the affected opening (e.g., site, building and door number).
- Corbin Russwin order number (located on product box), if available.
- Power supply manufacturer and rated output (i.e., voltage and current).
- Method of operation (e.g., Timer Mode).
- The number of devices connected to the power supply.
- Symptoms of problem (i.e., observed behavior).

4

Optional M93 Trim Monitor Switch

For MELR applications using the optional M93 trim monitor switch, the NO or NC output can be selected on the controller. Factory preset is NO, however to change to NC perform the following:

1. Remove the controller for the exit device.
2. Move the trim monitor switch wire harness to the desired configuration as shown in Figure 22.
3. Place the controller back into the Exit Device, ensuring that the tab is attached to the Exit Device chassis.

NOTE:

Connector position is relative to the block.

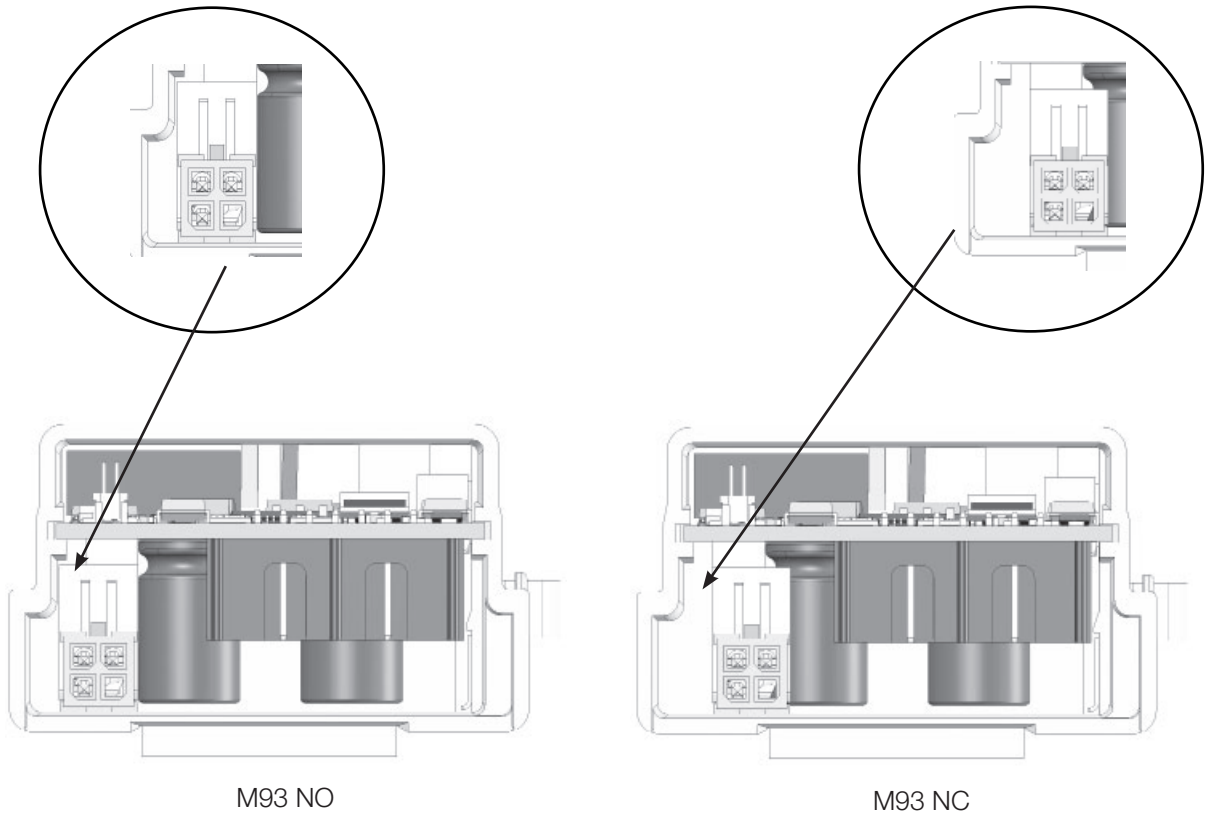
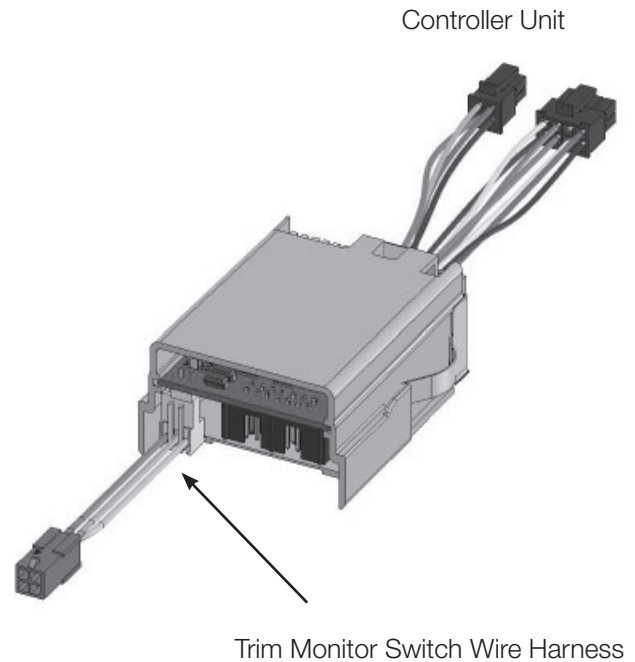

Figure 20 Changing M93 Preset

The ASSA ABLOY Group is the global leader in access solutions. Every day, we help billions of people experience a more open world.

ASSA ABLOY Opening Solutions leads the development within door openings and products for access solutions in homes, businesses and institutions. Our offering includes doors, frames, door and window hardware, locks, perimeter fencing, access control and service.



Corbin Russwin, Inc.
225 Episcopal Road
Berlin, CT 06037 USA
Phone: 800-543-3558
Fax: 800-447-6714
www.corbinrusswin.com

Corbin Russwin is a brand associated with ASSA ABLOY Access and Egress Hardware Group, Inc., an ASSA ABLOY Group company. Copyright © 2016, 2020, ASSA ABLOY Access and Egress Hardware Group, Inc. All rights reserved. Reproduction in whole or in part without the express written permission of ASSA ABLOY Access and Egress Hardware Group, Inc. is prohibited.

For installation assistance contact Corbin Russwin
1-800-543-3658 • techsupport.corbinrusswin@assaabloy.com

FM434 07/20