

NOTES:

- BACKSET IS MEASURED FROM CENTERLINE OF BEVEL WHICH IS CENTERPOINT OF DOOR THICKNESS. REFER TO APPROPRIATE DEVICE TEMPLATE FOR BACKSET DIMENSION.
- NOTCHING OF 2-1/8 (54) DIAMETER CUTOUT PER ANSI STANDARDS A115.2 (STEEL) AND A115.W2 (WOOD) IS PERMISSIBLE BUT NOT REQUIRED. REFER TO APPROPRIATE ANSI A115 STANDARD FOR DETAILS.
- DIMENSIONS GIVEN IN INCHES AND (MM).

TEMPLATE CROSS REFERENCE		
DEVICE	DESCRIPTION	TEMPLATE
RIM	ED8200 & ED8200B SERIES	T30436
	ED8200 & ED8200B SERIES x M61 & M62	T30491
	ED8200A SERIES	T30465
	ED9200 & ED9200B SERIES	T30441
	ED9200 & ED9200B SERIES x M61 & M62	T30490
VERTICAL ROD	ED9200A SERIES	T30462
	ED8400 SERIES	T30437
	ED8400A SERIES	T30467
	ED9400 SERIES	T30431
	ED9400A SERIES	T30443

LHR SHOWN
RHR OPPOSITE

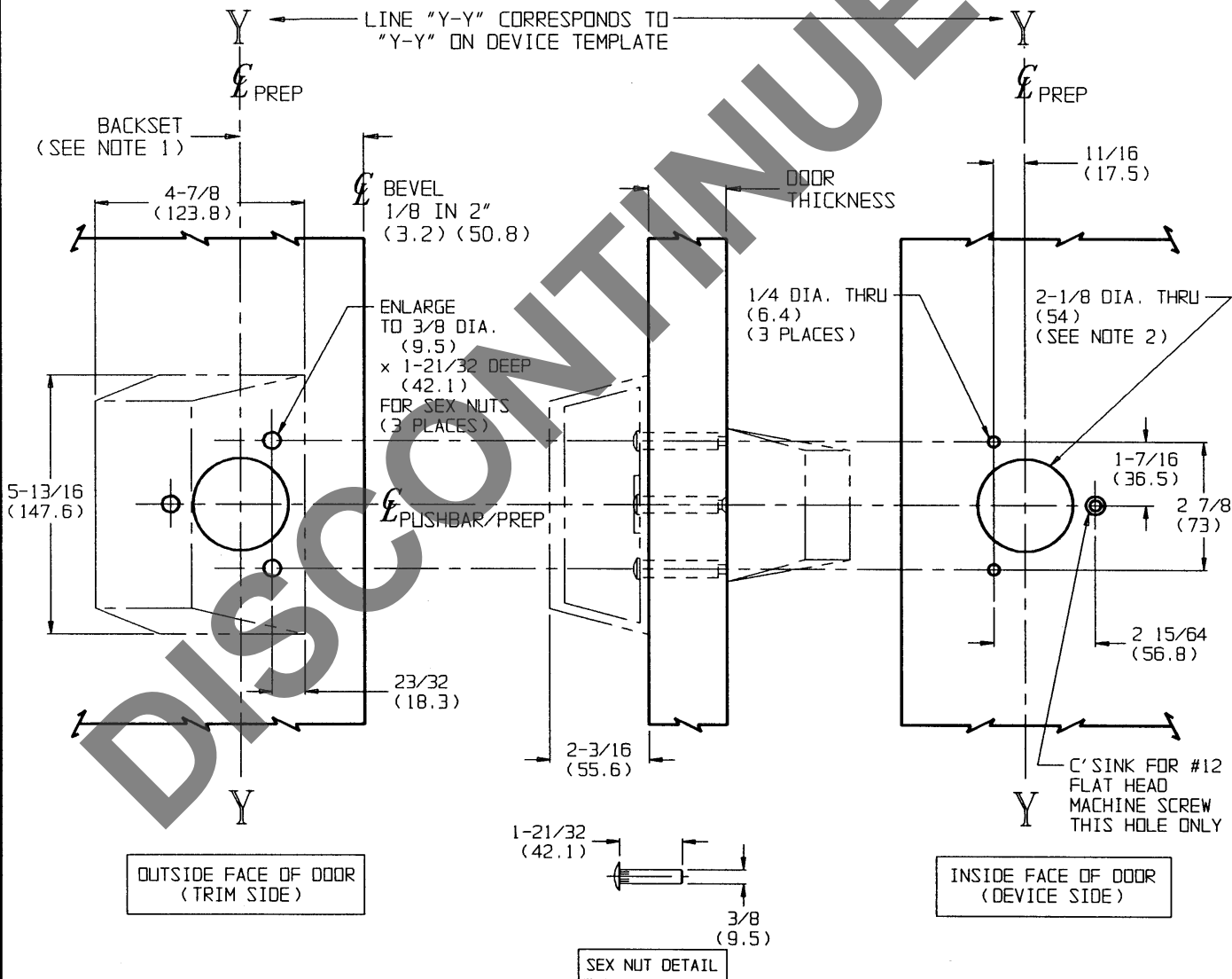

RESPONSIBILITY

Door and Frame Manufacturers are responsible for providing adequate construction or reinforcements for proper installation of hardware shown. All architectural builders hardware must be installed on properly reinforced doors and frames, regardless of the type, material, or method of construction.

P 257

PULL AND CYLINDER EXIT TRIM

Corbin Russwin
www.corbinrusswin.com

DO NOT SCALE DRAWING

SUPERSEDES	T 30483	DR.	BTH	APP.	
DATE	04/02/93	TEMPLATE NUMBER	T 30483 - 1		