

REQUIRED HOLES	FUNCTION					
	PE8804 PED5247 PE8840 PED5250	PE8806 PE8813 PE8815 PE8843 PE8846	PED5249 PED5245 PED5210 PED5255 PED5259	PE8810 PED5240 PE8840 PED5250	PE8873 PED52910 PE8874 PED52930	PE8875 PED52903 PE8876 PED52905
HOLE 1		X			X	X
HOLE 2	X					X

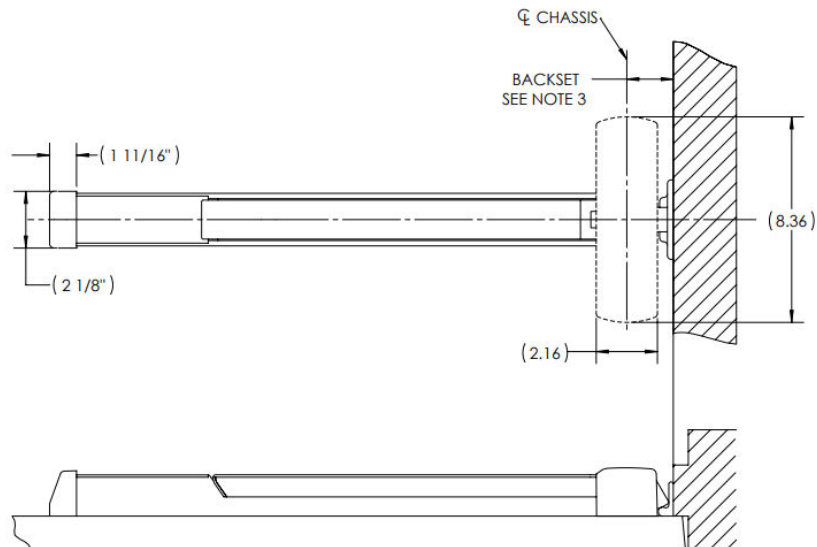

NOTES:

1. TOLERANCE ON ALL DIMENSIONS $\pm .031$.
2. WE RECOMMEND THAT ALL TAPPED HOLES BE DRILLED & TAPPED IN FIELD.
3. SEE STRIKE TEMPLATE FOR VERTICAL CENTER LINE OF CHASSIS.
4. SEE MASTER SHEET No. MEDT23 FOR AREAS REQUIRING REINFORCEMENTS.
5. SURFACE OF DOOR WHERE EXIT DEVICE IS TO BE APPLIED MUST BE FLUSH.
6. FOR GLASS BEADED DOORS, IF BEAD CANNOT BE REMOVED, USE GLASS SHIM KIT (AVAILABLE ON ORDER).
7. SEE TRIM TEMPLATES FOR OUTSIDE FACE PREPARATION.
8. SEE TEMPLATES No. MEDT17 FOR ELECTROLYNX DETAILS WHEN NEEDED.

ASSA ABLOY
 Opening Solutions

DOOR MANUFACTURERS TEMPLATE:
 RIM EXIT DEVICE

RELEASE DATE

4/22/22

TEMPLATE NO.

MEDT44