

Series
SN200 Wiegand
SN210 OSDP
ED5000 Series
Exit Device
With MELR

Attention Installer:

Please read these instructions carefully to prevent missing important steps.

Improper installations may result in damage to the lock and void the factory warranty.

The accuracy of the door preparation is critical for proper functioning and security of this lock.

Misalignment can cause premature wear and a lessening of security.

For Technical Assistance call Corbin Russwin at 1-800-810-WIRE (9473)

Table of Contents

1) Regulatory Compliance 3
2) Warning 3
3) Specifications..... 4
4) Product Illustrations 5
5) Wiring Diagrams..... 7
6) Installation Instructions 11
7) MELR Device and Configuration Check 23
8) Door Position Switch (DPS) Installation 24
9) Operational Check 25

Installation Instructions

SN200/210 ED5000 Series Exit Device

With MELR

1) Regulatory Compliance

Changes or modifications to this unit not expressly approved by the party responsible for compliance could void the user's authority to operate the equipment.

FCC:

This equipment has been tested and found to comply with the limits for a Class B digital device, pursuant to Part 15 of the FCC Rules. These limits are designed to provide reasonable protection against harmful interference in a residential installation. This equipment generates, uses, and can radiate radio frequency energy and, if not installed and used in accordance with the instructions, may cause harmful interference to radio communications. However, there is no guarantee that interference will not occur in a particular installation. If this equipment does cause harmful interference to radio or television reception, which can be determined by turning the equipment off and on, the user is encouraged to try to correct the interference by one or more of the following measures:

- Reorient or relocate the receiving antenna.
- Increase the separation between the equipment and receiver.
- Connect the equipment into an outlet on a circuit different from that to which the receiver is connected.
- Consult the dealer or an experienced radio/TV technician for help.

Industry Canada:

This Class B digital apparatus meets all requirements of the Canadian Interference Causing Equipment Regulations. Operation is subject to the following two conditions: (1) this device may not cause harmful interference, and (2) this device must accept any interference received, including interference that may cause undesired operation.

Cet appareillage numérique de la classe B répond à toutes les exigences de l'interférence canadienne causant des règlements d'équipement. L'opération est sujette aux deux conditions suivantes: (1) ce dispositif peut ne pas causer l'interférence nocive, et (2) ce dispositif doit accepter n'importe quelle interférence reçue, y compris l'interférence qui peut causer l'opération peu désirée.

This equipment complies with FCC radiation exposure limits set forth for an uncontrolled environment. This equipment should be installed and operated with minimum distance 20cm between the radiator and your body. This transmitter must not be co-located or operating in conjunction with any other antenna or transmitter.

Cet équipement est conforme aux limites d'exposition aux radiations de la FCC définies pour un environnement non contrôlé. Cet équipement doit être installé et utilisé à une distance minimale de 20 cm entre le radiateur et votre corps. Cet émetteur ne doit pas être co-localisé ou fonctionner en conjonction avec une autre antenne ou un autre émetteur.

Under Industry Canada regulations, this radio transmitter may only operate using an antenna of a type and maximum (or lesser) gain approved for the transmitter by Industry Canada. To reduce potential radio interference to other users, the antenna type and its gain should be so chosen that the equivalent isotropically radiated power (e.i.r.p.) is not more than that necessary for successful communication.

Conformément à la réglementation d'Industrie Canada, le présent émetteur radio peut fonctionner avec une antenne d'un type et d'un gain maximal (ou inférieur) approuvé pour l'émetteur par Industrie Canada. Dans le but de réduire les risques de brouillage radioélectrique à l'intention des autres utilisateurs, il faut choisir le type d'antenne et son gain de sorte que la puissance isotrope rayonnée équivalente (p.i.r.e.) ne dépasse pas l'intensité nécessaire à l'établissement d'une communication satisfaisante.

2) Warning



This product can expose you to lead which is known to the state of California to cause cancer and birth defects or other reproductive harm. For more information go to: www.P65warnings.ca.gov.

Ce produit peut vous exposer au plomb qui, dans l'état de la Californie, est reconnu pour causer le cancer, des anomalies congénitales ou d'autres problèmes de reproduction.

Pour plus d'informations, visitez: www.P65warnings.ca.gov.



Any retrofit or other field modification to a fire rated opening can potentially impact the fire rating of the opening, and Corbin Russwin makes no representations or warranties concerning what such impact may be in any specific situation. When retrofitting any portion of an existing fire rated opening, or specifying and installing a new fire-rated opening, please consult with a code specialist or local code official (Authority Having Jurisdiction) to ensure compliance with all applicable codes and ratings.

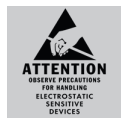

To avoid possible damage from electrostatic discharge (ESD), some basic precautions should be used when handling electronic components:

- Minimize build-up of static by touching and/or maintaining contact with unpainted metal surfaces such as door hinges, latches, and mounting plates especially when mounting electronic components such as readers and controllers onto the door.
- Leave components (reader and controller) protected in their respective anti-static bags until ready for installation
- Do not touch pins, leads or solder connections on the circuit boards

***WARNING:** The system shall not be installed in the fail-secure mode unless permitted by the local authority having jurisdiction and shall not interfere with the operation of Listed panic hardware.

3) Specifications

- UL Listed* - UL 294 Indoor Use
- CUL Listed - S319: Class 1
- ANSI/BHMA A156.25 Listed Grade 1 Compliant

*UL294, S319, & BHMA A156.25 not applicable to SN200 with Non-UL294 Configuration option

- UL 294 Access Control Ratings:

Destructive Attack	Level 1
Line Security	Level 1
Endurance	Level 4
Standby Power	Level 1

UL testing was conducted on product powered by UL Listed model 9001GR/AC injector; manufactured by Microsemi Corp.

Electrical Specifications

12/24VDC System

	12V		24V	
	Average	Peak	Average	Peak
Reader**	75mA	250mA	n/a	n/a
Actuator	15mA	500mA	15mA	500mA

**Maximum AVG - RMS current draw during continuous card reads Not evaluated by UL.

Peak - highest instantaneous current draw during RF communication

The reader requires 12VDC for power, while the lock accepts either 12 or 24VDC.

Wire from EAC Panel to door must be shielded with a drain terminated at EAC Panel controller

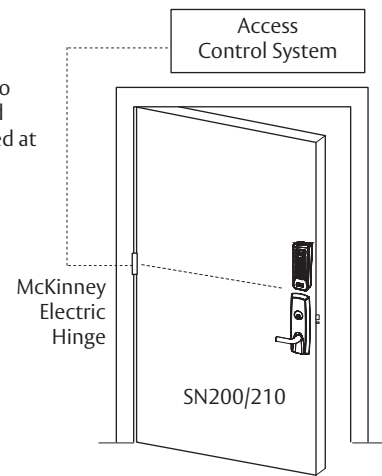

OSDP** and Wiegand Wire Specifications

Total One-Way Length of Wire Run (ft)	Wire Gauge Chart 12VDC Load Current @ 12VDC							
	1/4A	1/2A	3/4A	1A	1-1/4A	1-1/2A	2A	3A
100	20	18	16	14	14	12	12	10
150	18	16	14	12	12	12	10	—
200	16	14	12	12	10	10	—	—
250	16	14	12	10	10	10	—	—
300	16	12	12	10	10	—	—	—
400	14	12	10	—	—	—	—	—
500	14	10	10	—	—	—	—	—
750	12	10	—	—	—	—	—	—
1,000	10	—	—	—	—	—	—	—
1,500	10	—	—	—	—	—	—	—

Total One-Way Length of Wire Run (ft)	Wire Gauge Chart 24VDC Load Current @ 24VDC							
	1/4A	1/2A	3/4A	1A	1-1/4A	1-1/2A	2A	3A
100	24	20	18	18	16	16	14	12
150	22	18	16	16	14	14	12	10
200	20	18	16	14	14	12	12	10
250	18	16	14	14	12	12	12	10
300	18	16	14	12	12	12	10	—
400	18	14	12	12	10	10	—	—
500	16	14	12	10	10	—	—	—
750	14	12	10	10	—	—	—	—
1,000	14	10	10	—	—	—	—	—
1,500	12	10	—	—	—	—	—	—

†Recommended wire specifications for OSDP: Four (4) conductor twisted pair overall shield such as UL approved, Belden 3107A or equivalent is recommended to remain fully TIA-485 compliant at maximum supported baud rates and cable distances. Belden 82842, Liberty Wire & Cable 24-29_P485-WHT, West Penn Wire D254852, and CAT6 cable have been found to be suitable in typical applications and installations, including lower baud rates and cabling distances.

This product is not intended for outside wiring as covered by Article 800 in the National Electrical Code, NFPA 70.

Wiring methods shall be in accordance with the National Electrical Code (ANSI/NFPA70), CSA 22.1, Canadian Electrical Code (CEC), Part I, Safety Standard for Electrical Installations, local codes and the authorities having jurisdiction.

Both reader and actuator current must be taken into account when determining wire length and gauge. OSDP installations may be more limited due to fewer cable options.

For OSDP cable lengths greater than 200 ft (61 m) or EMF interference, install 120Ω +/- 2Ω resistor across RS-485 termination ends.

4) Product Illustrations

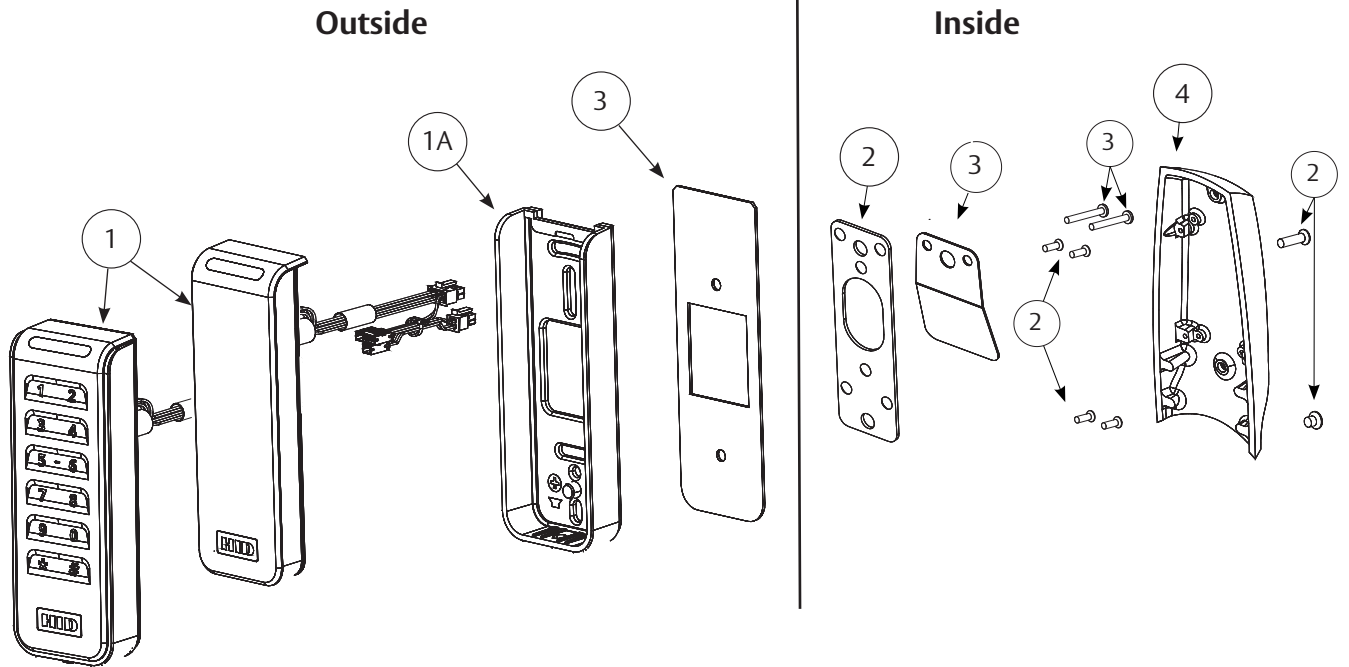

ITEM	DESCRIPTION	
1	SN200 Reader & Harness Assembly (Wiegand/OSDP)	1
1A	Signo Reader Back Plate	1
2	Mounting Packet	1
3	Fire Plate Packet	1
4	Inside Escutcheon	1

See document FM643 for part numbers

Tools Required:

- #2 Phillips Screwdriver (Standard size)
- Flat Blade Screwdriver (Standard size)
- 1/8" Allen Wrench
- T10 Torx Security Screwdriver

4) Product Illustrations (Continued)

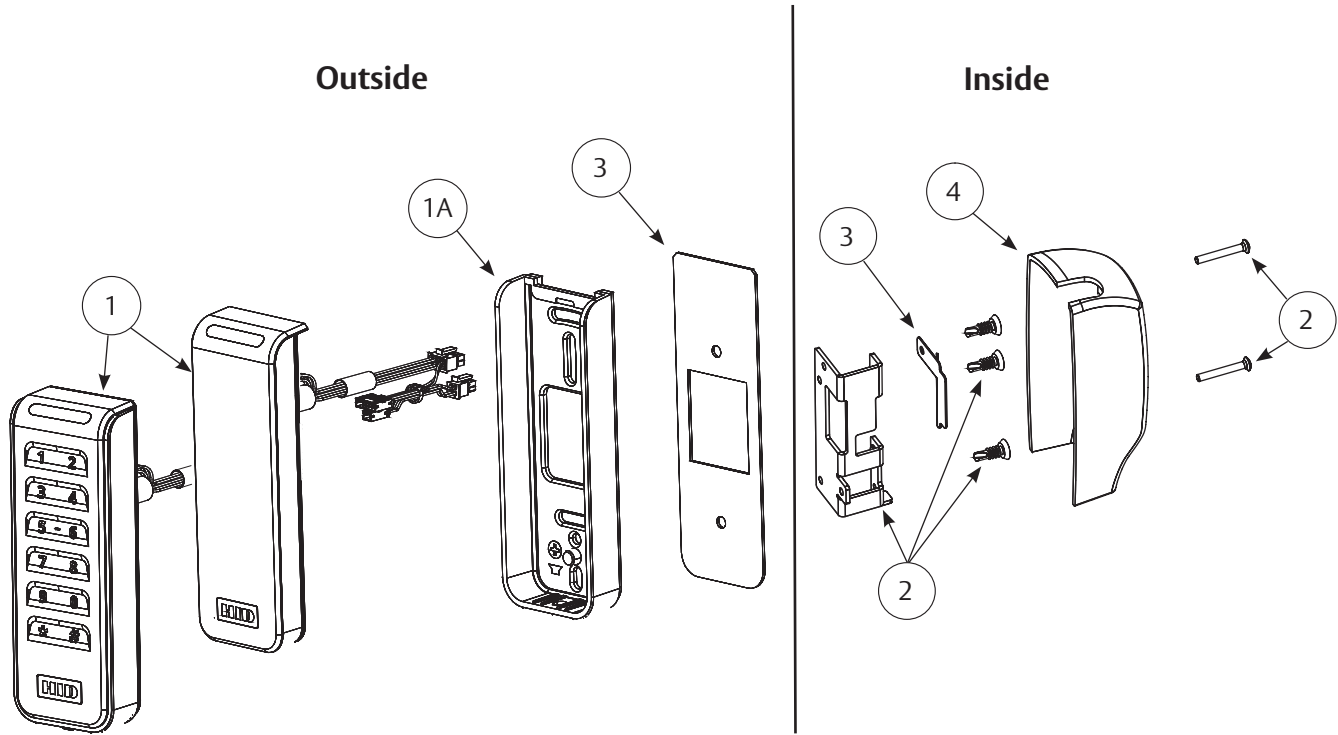

ITEM	DESCRIPTION	
1	SN200/210 Reader & Harness Assembly (Wiegand/OSDP)	1
1A	Signo Reader Back Plate	1
2	Mounting Packet	1
3	Fire Plate Packet	1
4	Inside Escutcheon	1

See document FM643 for part numbers

Tools Required:

- #2 Phillips Screwdriver (Standard size)
- Flat Blade Screwdriver (Standard size)
- 1/8" Allen Wrench
- T10 Torx Security Screwdriver

5) Wiring Diagrams

Product	8 PIN CONNECTOR								4 PIN CONNECTOR			
	1-Black	2-Red	3-White	4-Green	5-Orange	6-Blue	7-Brown	8-Yellow	1-Violet	2-Gray	3-Pink	4-Tan
ACCESS CONTROL DEVICES: SN200/210 Lockset, ElectroLynx wire Color / Function assignments												
	12VDC (Reader)		Communication Type		RX	RX	EGND	Function*	12/24 VDC (LOCK RELAY)		DPS	DPS
SN200 (UL294)	NEG	POS	WIEGAND DATA_1	WIEGAND DATA_0	NO	COM	EGND	TAMPER	NEG	POS	NC	COM
SN200								GREEN LED				
SN210			OSDP RS-485B	OSDP RS-485A				n/a				

*Diagrams on following pages

If your lock is configured with End of Line Resistors, reference instruction sheet FM406 for the wiring of RX & DPS outputs.

Wiegand Operation Mode:

- Red LED 'ON' when powered.
- Presenting a compatible credential causes LED to briefly turn green and then return to red state.

UL294 / TAMPER Configuration:

- Connect Yellow TAMPER wire from ElectroLynx cable to desired EAC panel control line. Reference Diagram #1.
- As appropriate, use the configuration card to activate desired mode on reader.

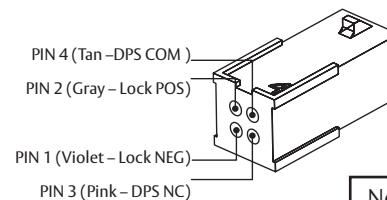
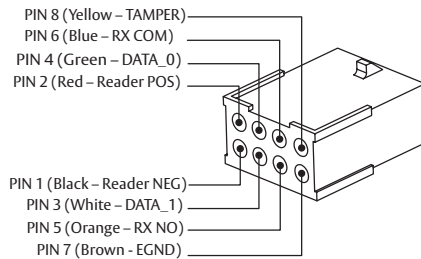

Note: NC= Normally Closed
NO= Normally Open

Non-UL294 Configuration:

- Connect GREEN_LED input to switch controlled by panel. Shorting GREEN_LED to READER_NEG (Black) with panel switch will override reader LED to keep it green.

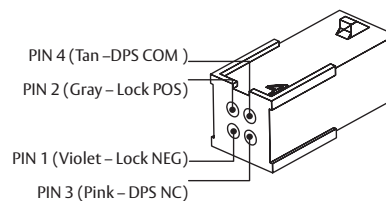
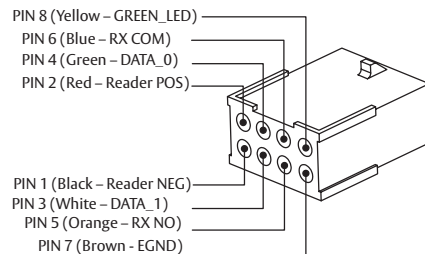

5) Wiring Diagrams (Continued)

SN200 Wiegand UL294/TAMPER Configuration Application Diagram #1

Tamper will trigger when reader is removed from door and tamper wiring is connected at the panel.

Reader Electronics Requires 12VDC Filtered and Regulated

	12V		24V	
	Average	Peak	Average	Peak
Reader**	75mA	250mA	n/a	n/a
Actuator (ET)	15mA	500mA	15mA	500mA

*UL294, S319, & BHMA A156.25 not applicable to SN200 with Non-UL294 Configuration option

**Maximum AVG - RMS current draw during continuous card reads Not evaluated by UL

Peak - highest instantaneous current draw during RF communication

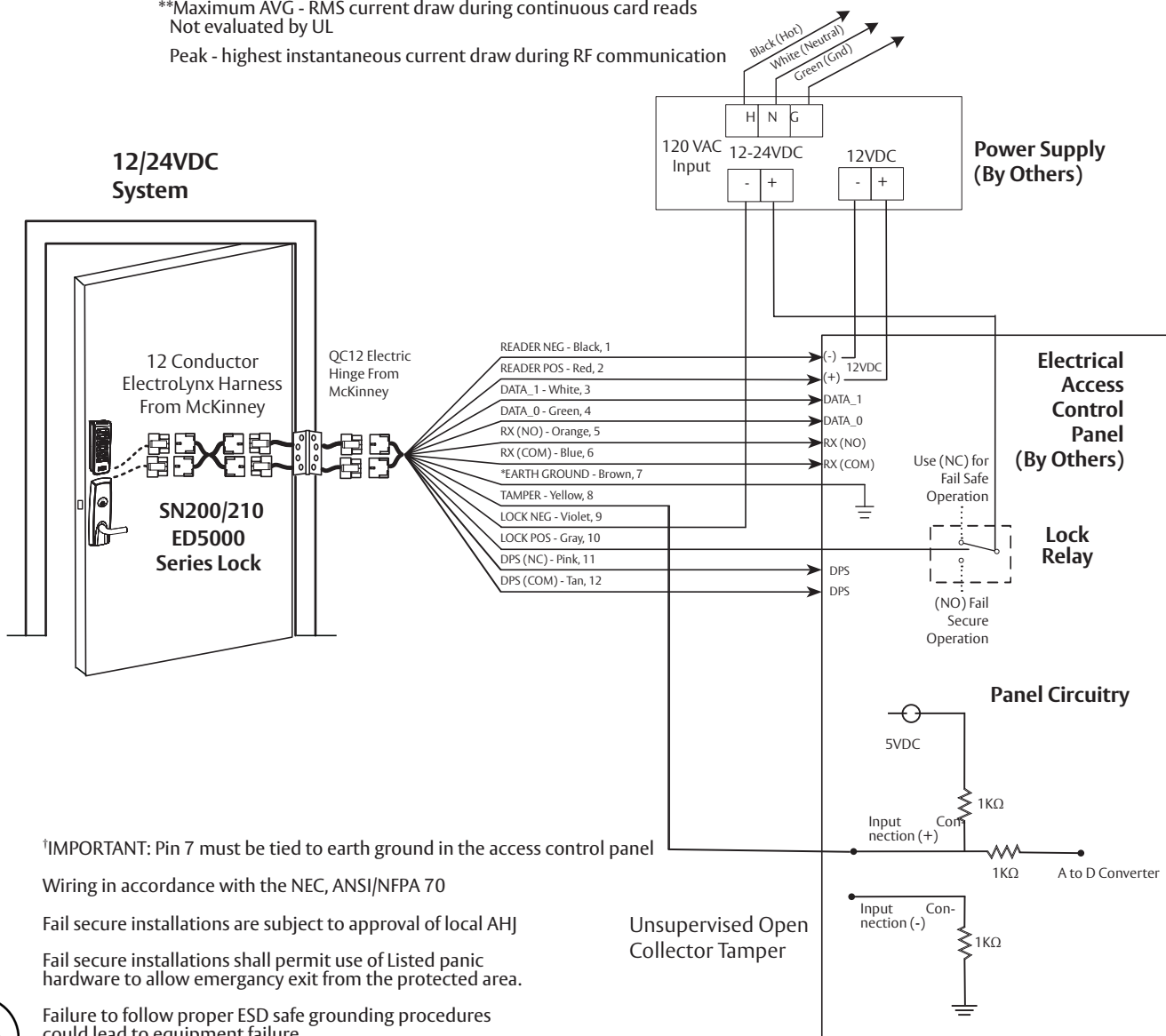

[†]IMPORTANT: Pin 7 must be tied to earth ground in the access control panel

Wiring in accordance with the NEC, ANSI/NFPA 70

Fail secure installations are subject to approval of local AHJ

Fail secure installations shall permit use of Listed panic hardware to allow emergency exit from the protected area.

Failure to follow proper ESD safe grounding procedures could lead to equipment failure.

UL294 is a United States based standard.



5) Wiring Diagrams (Continued)

SN200 Wiegand Non-UL294 Configuration Application Diagram #2

Connect GREEN_LED input to switch controlled by panel. Shorting GREEN_LED to READER_NEG (Black) with panel switch will override reader LED to keep it green.

	12V		24V	
	Average	Peak	Average	Peak
Reader*	75mA	250mA	n/a	n/a
Actuator (ET)	15mA	500mA	15mA	500mA

*Maximum AVG - RMS current draw during continuous card reads
Not evaluated by UL

Peak - highest instantaneous current draw during RF communication

Reader Electronics Requires 12VDC Filtered and Regulated

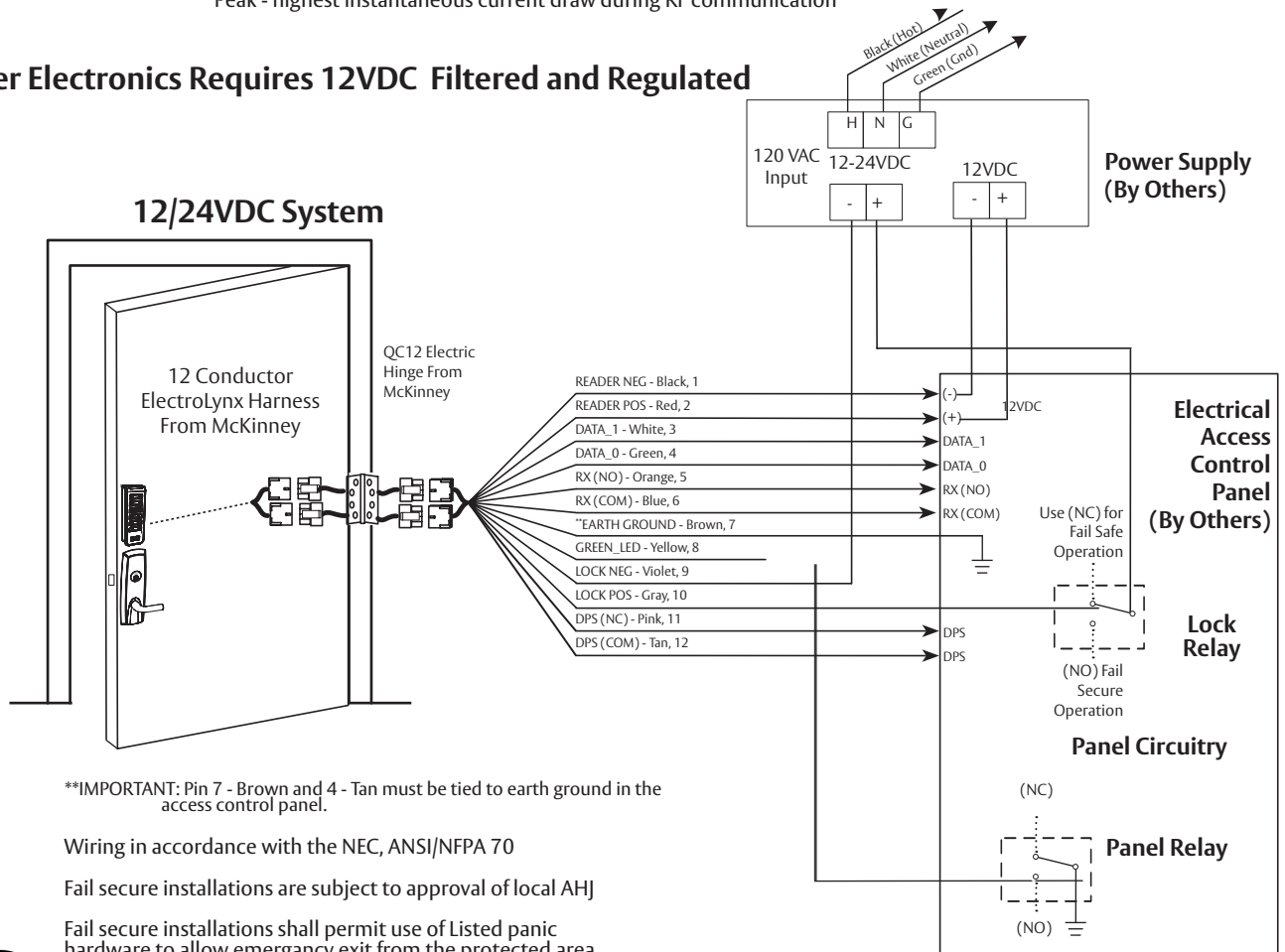

****IMPORTANT:** Pin 7 - Brown and 4 - Tan must be tied to earth ground in the access control panel.

Wiring in accordance with the NEC, ANSI/NFPA 70

Fail secure installations are subject to approval of local AHJ

Fail secure installations shall permit use of Listed panic hardware to allow emergency exit from the protected area.



Failure to follow proper ESD safe grounding procedures could lead to equipment failure.

UL294 is a United States based standard.

5) Wiring Diagrams (Continued)

SN210 OSDP (MELR) Application Diagram #3 (12/24VDC System)

	12V		24V	
	Average	Peak	Average	Peak
Reader**	75mA	250mA	n/a	n/a
Actuator (ET)	15mA	500mA	15mA	500mA
MELR	n/a	n/a	250mA dogged	1A inrush during retraction

OSDP Operation Mode*:

*LED/Sounder control and Tamper status communicated over OSDP serial protocol

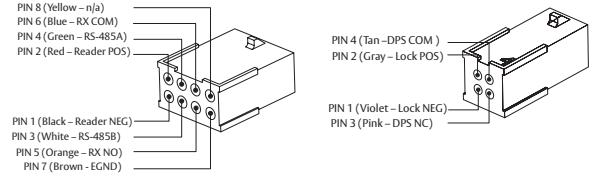

**Maximum AVG - RMS current draw during continuous card reads
Not evaluated by UL

Peak - highest instantaneous current draw during RF communication

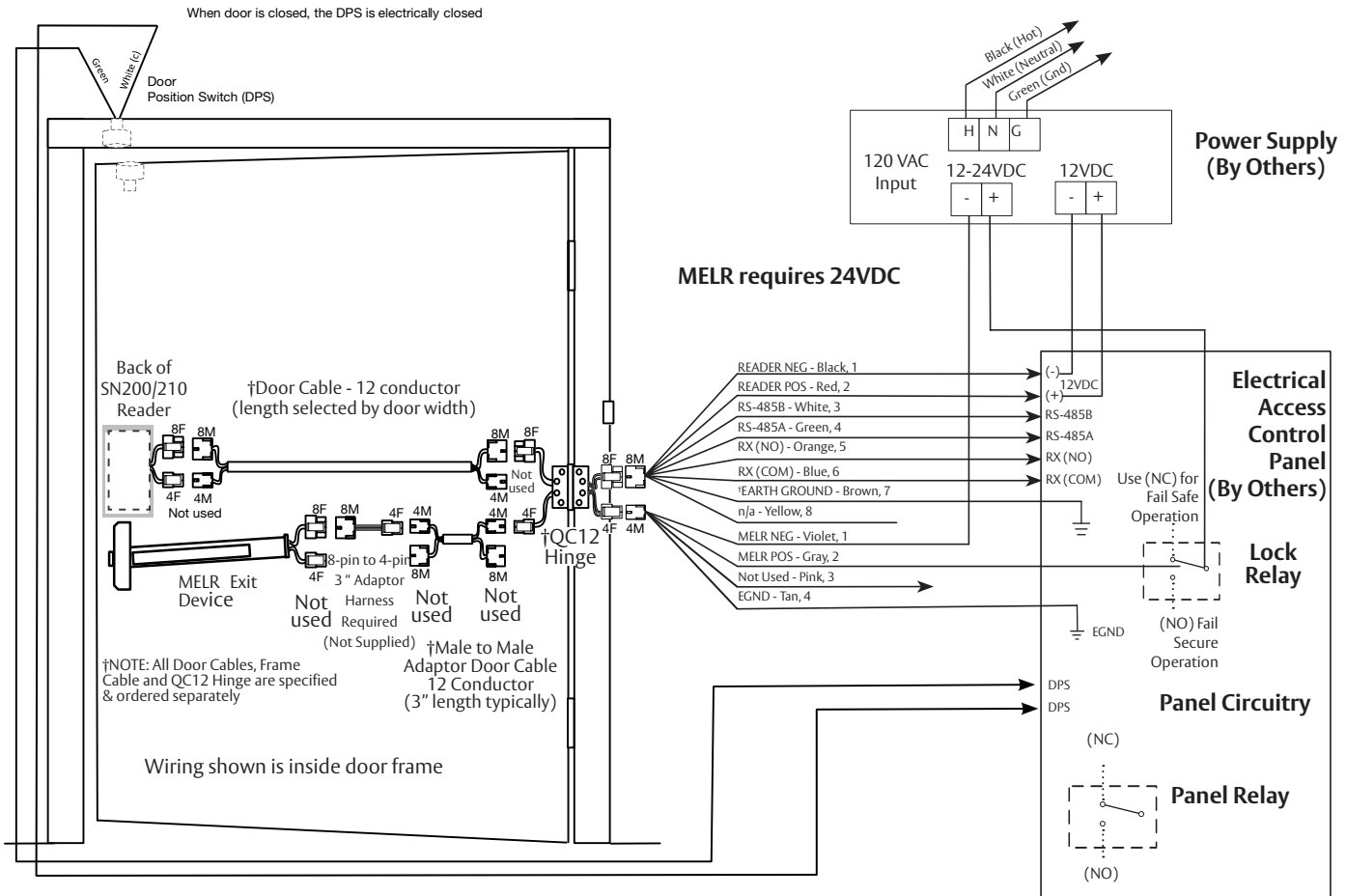

†IMPORTANT: Pin 7 must be tied to earth ground in the access control panel.

Wiring in accordance with the NEC, ANSI/NFPA 70

Fail secure installations are subject to approval of local AHJ

Fail secure installations shall permit use of Listed panic hardware to allow emergency exit from the protected area.

Failure to follow proper ESD safe grounding procedures could lead to equipment failure.

For OSDP cable lengths greater than 200 ft (61 m) or EMF interference, install 120Ω +/- 2Ω resistor across RS-485 termination ends.



6) Installation Instructions

1. Verify Hand and Bevel of door:

Door should be fitted and hung.
 Verify box label for size of exit device,
 function and hand.

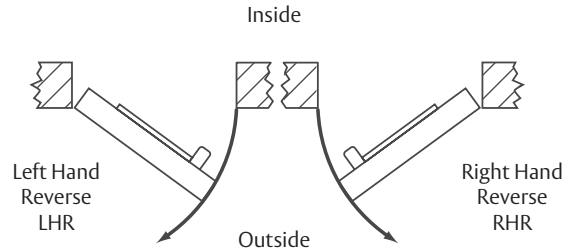

Fig. 1

2. Prep door according to supplied door markers:

Outside - **FM382** for Rim/SVR/CVR; **FM386** for Mortise.

Inside - **FM387**

NOTE: Reference the following instructions for rail installation:

- FM156 Rim (standard)
- FM532 Rim (SecureBolt®)
- FM164 SVR
- FM171 CVR
- FM168 Mortise

For door manufacturer templates visit
www.corbinrusswin.com and refer-
 ence template numbers:

	Wood	Metal
Rim	T31215	T31216
CVR	T31215	T31216
SVR	T31218	T31219
Mortise	T31217	

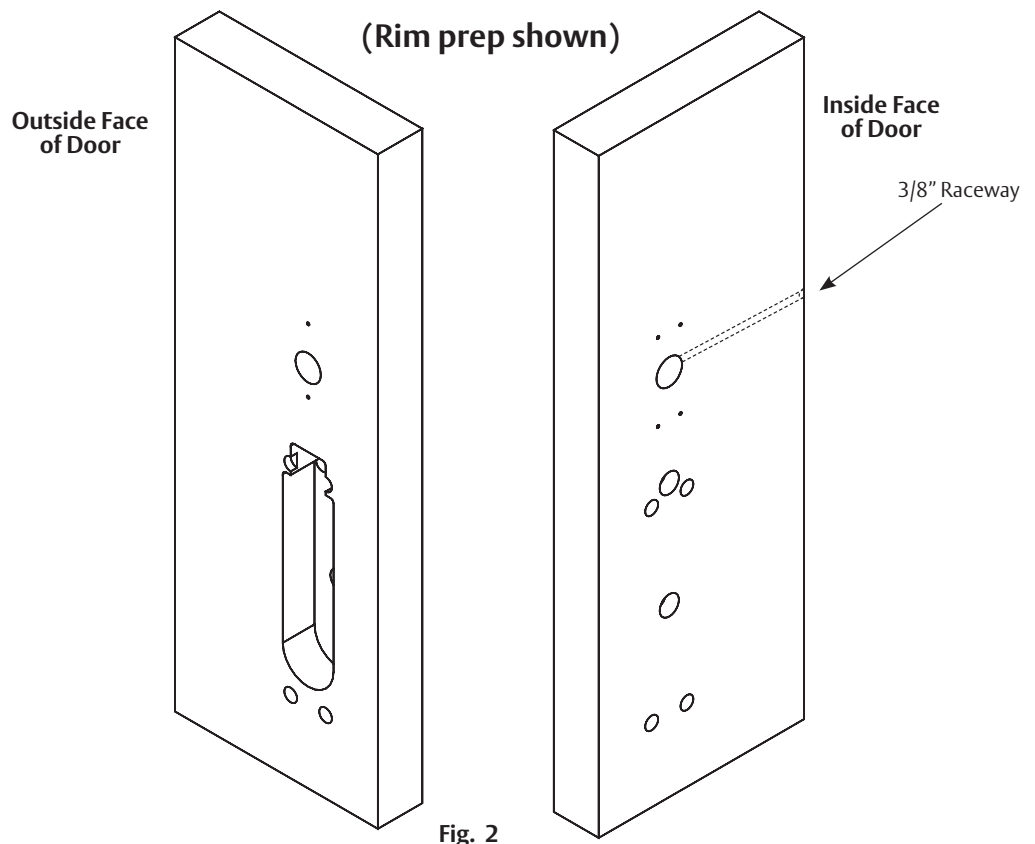

6) Installation Instructions (Continued)

3. Install Reader Backplate and (Optional*) Fire Shield

For fire-rated doors only, install reader backplate and fire shield to door using two (2) #8-18 x 5/8" Phillips flat head self-drilling screws (Fig. 3a, b).

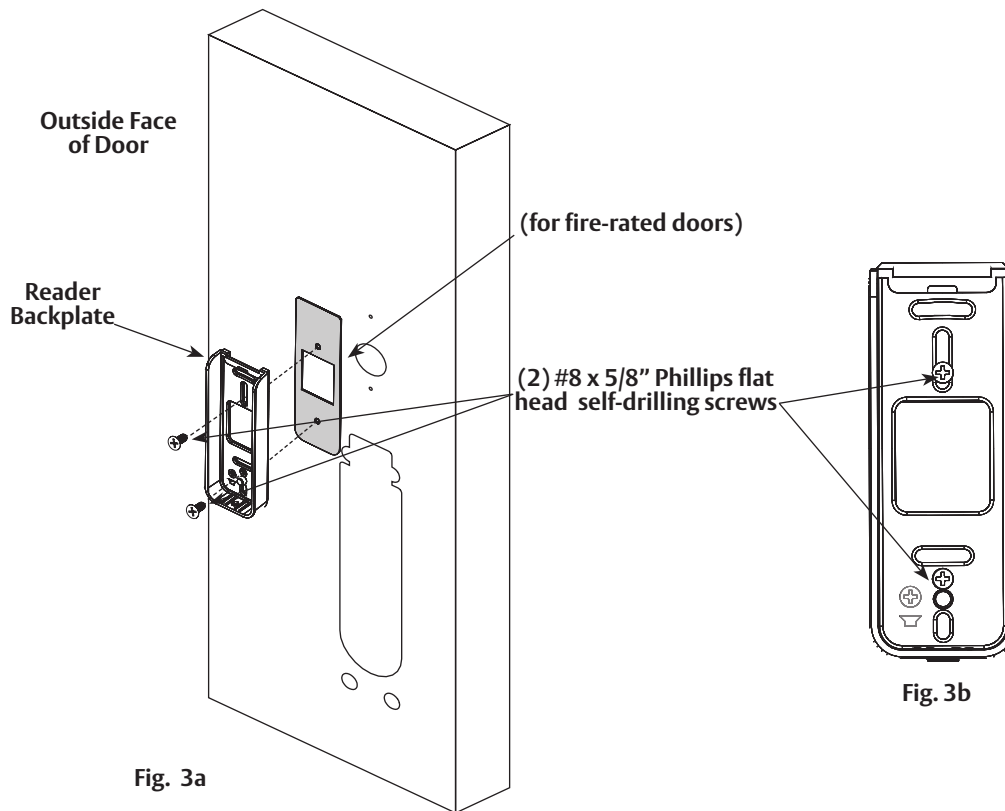

6) Installation Instructions (Continued)

4. Install SN200/210 Reader:



Observe precautions for handling electrostatic sensitive devices.

1. Hook the top of the reader on the top of the mounting plate.
2. Align the bottom of the reader with the bottom of the mounting plate.
3. Secure the reader to the mounting plate using the supplied 6-32 x 3/8" T10 security Torx machine screw (Fig. 4c).

Rim/SVR/CVR shown, assembly is same for mortise

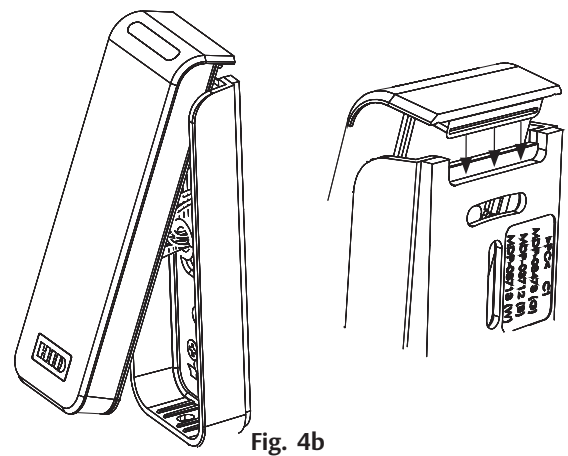
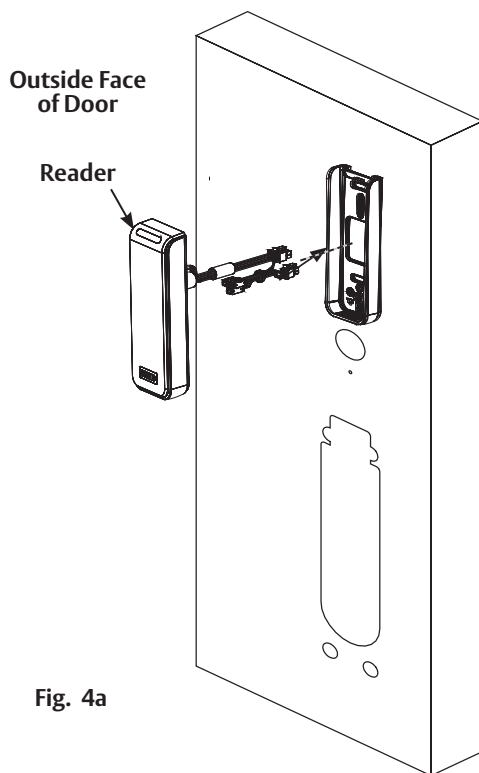

Bottom
View of
Reader



Detail

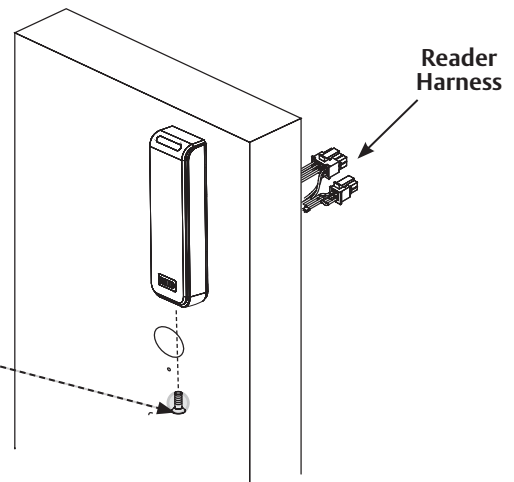

6) Installation Instructions (Continued)

5. Trim Assembly Instructions:

a. Check cylinder components:

Cylinders longer than 1-1/8" (29mm) require collars.
Refer to Cylinder Collar Chart (Fig. 5a).

(for Mortise, skip to Step 6)

b. If required, modify by cutting cylinder tailpiece:

Correct length is 1/16" to 3/16" (2 to 5mm)
beyond cylinder housing cam.

c. Assemble cylinder:

1. Insert cylinder housing prongs into matching notches of escutcheon.
2. Pass cylinder tailpiece through cylinder collar (if required) and slot in cylinder cam.
3. Fasten cylinder in escutcheon recess or collar using 2 mounting screws.

Do not overtighten screws.

d. Escutcheon Assembly (Fig. 5b):

The lever is handed (LHR shown).

Note: Lever Return Spring handing can be identified by color of the spring:

- LHR: (Red)
- RHR: (Blue)

Cylinder Collar Chart		
Cylinder Length		Collar
Inches	Millimeters	
1-1/8"	29mm	None
1-1/4"	32mm	422F88*
1-1/2"	38mm	686F98*

*Specify Finish

Fig. 5a

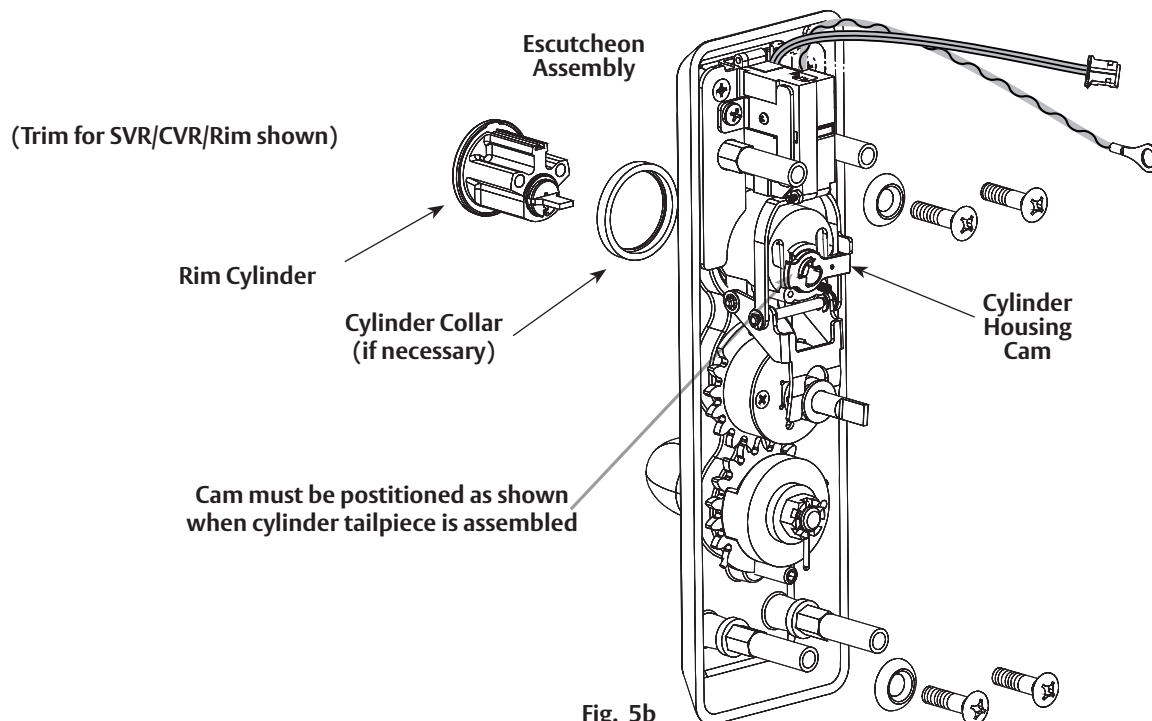

Fig. 5b

6) Installation Instructions (Continued)

6. Install Mortise and Outside Trim Assembly:

Install mortise lock following FM168 instructions, but do not install armored front at this time.

a. Feed lock wire through wire harness hole; seat lockbody firmly into mortised pocket (Fig. 6a).

b. Mount trim to door.

c. Fasten trim assembly to door using (2) 1/4-20 oval head screws and (2) finish washers (Fig. 6b).

Note: Finger tighten only.

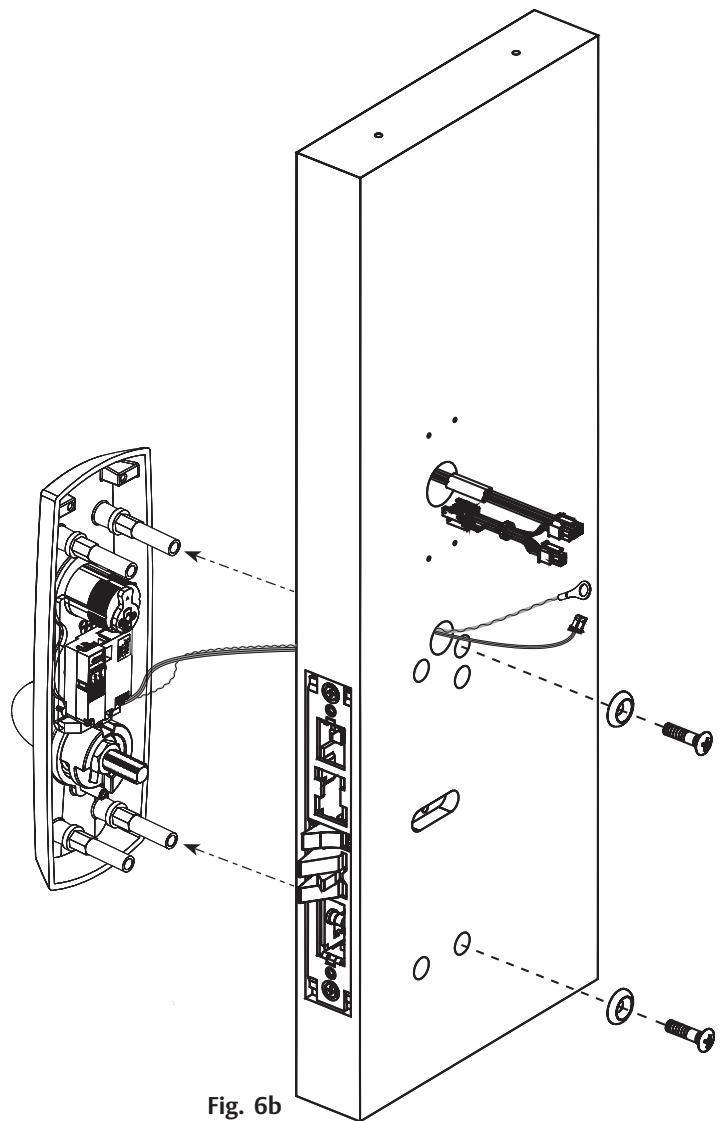
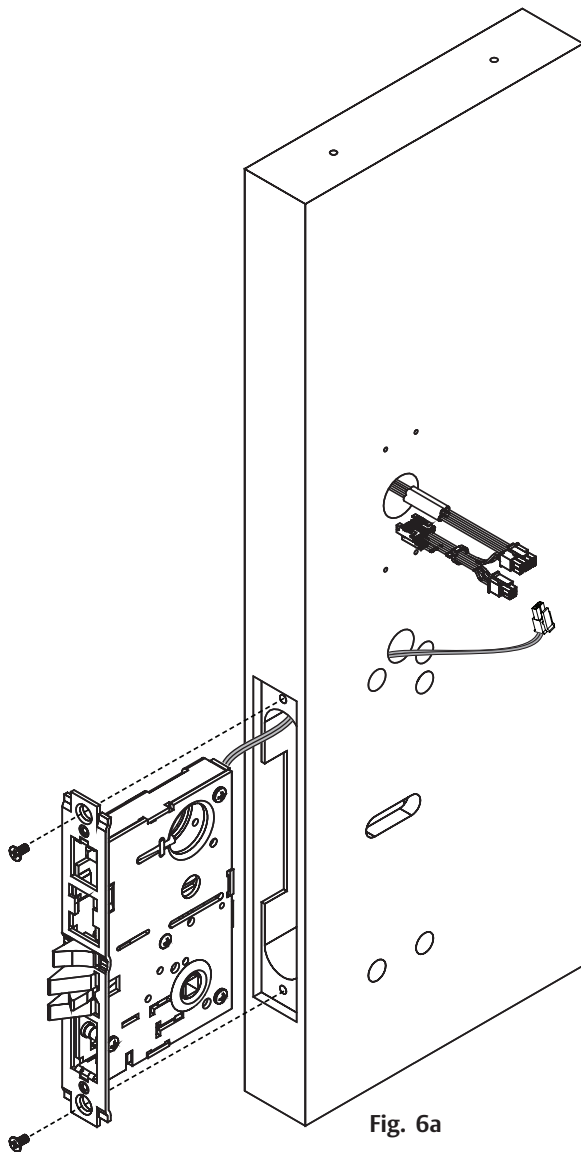

6) Installation Instructions (Continued)

6. Install Mortise and Outside Trim Assembly (Continued):

- d. Tighten down set screw to prevent cylinder movement (Fig. 6c).
- e. Install armored front (Fig. 6d).

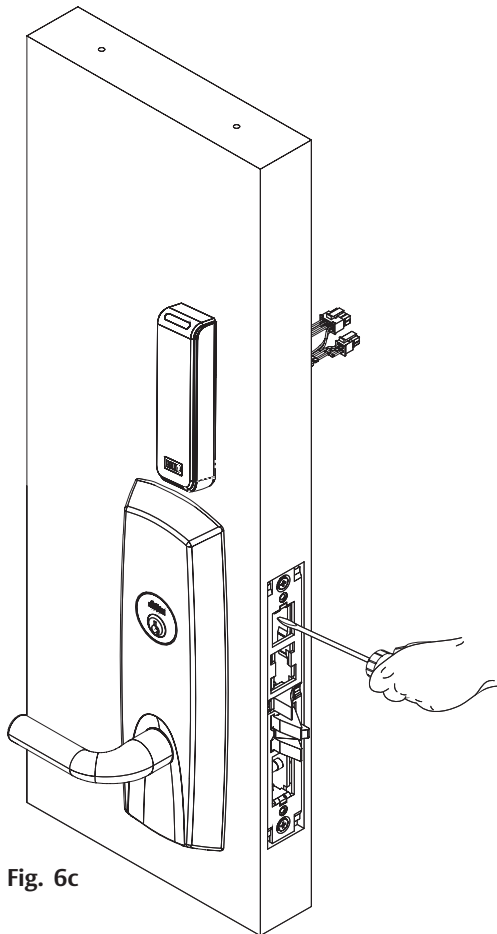

Fig. 6c

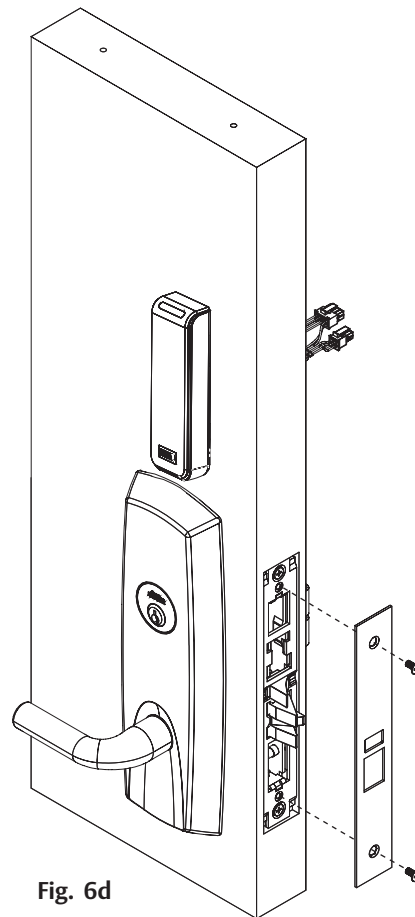

Fig. 6d

6) Installation Instructions (Continued)

7. Install Outside Trim Assembly (Rim/CVR/SVR):

- a. Make sure tailpiece is oriented vertically.
- b. Feed trim wire harness through wire harness hole (Fig. 7).
- c. Mount trim assembly to door pulling slack wire towards device side of door.
Note: Be careful not to pinch wire harness.
- d. When mounting trim, lift tailpiece to pass through hole on device side (Fig. 7).
Note: Ensure tailpiece is still oriented vertically.
- e. Fasten trim assembly to door using (2) 1/4-20 oval head screws and (2) finish washers (Fig. 7).
Note: Finger tighten only.

Caution: When installing trim, pull wires completely through door to avoid contacting motor assembly, as this may cause loss of function.

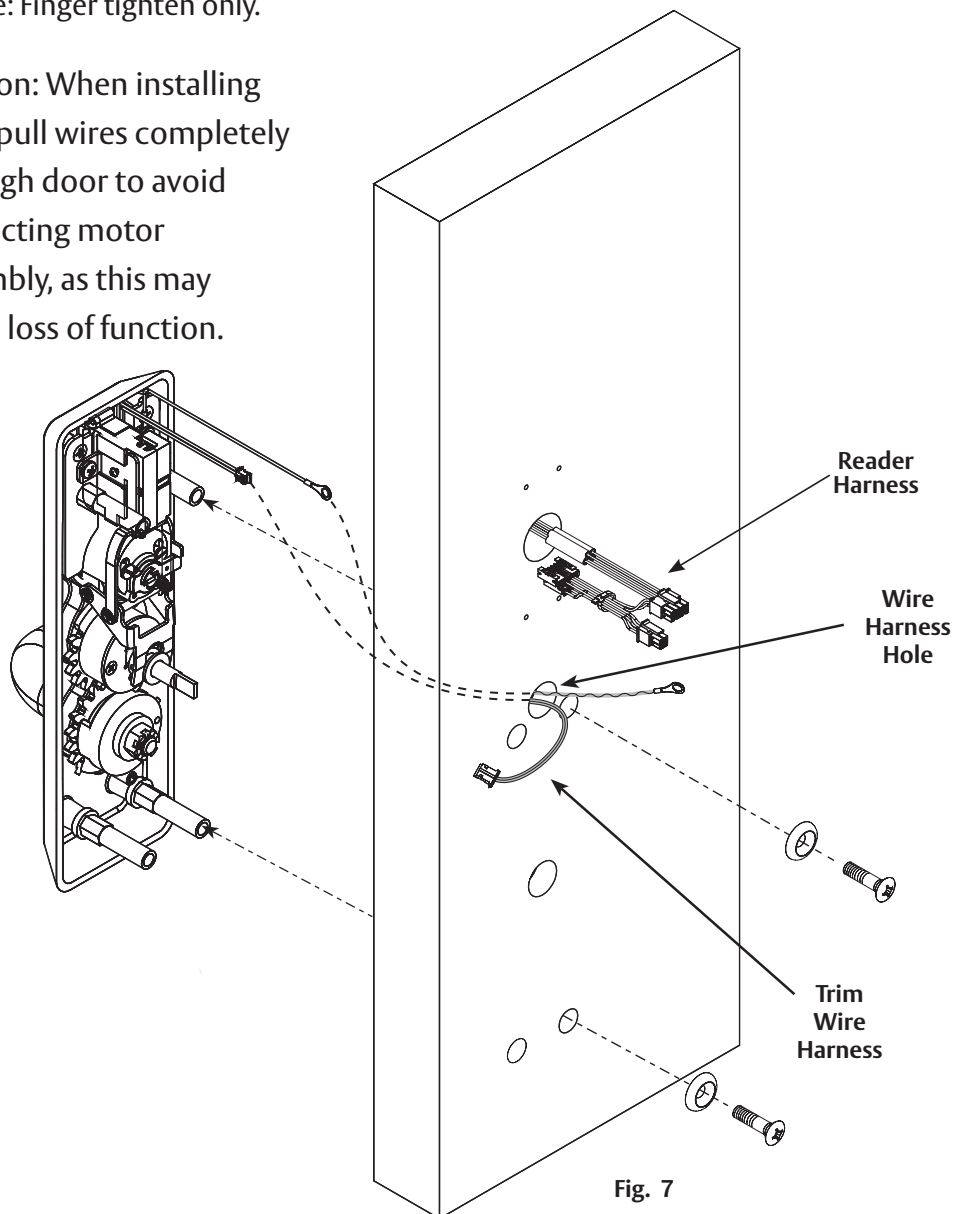

6) Installation Instructions (Continued)

8. Install Exit Device:

Follow instructions packed with device to secure device to door.

9. Install Head Cover:

- Lay wire device harnesses across $\frac{3}{4}$ " hole (Fig. 9a).
- Tuck wires into hole when installing cover so that wires are not pinched between head cover and door.
- Attach head cover using (2) #8-32 flat head screws (Fig. 9b).

Rim/SVR/CVR shown, assembly is same for mortise

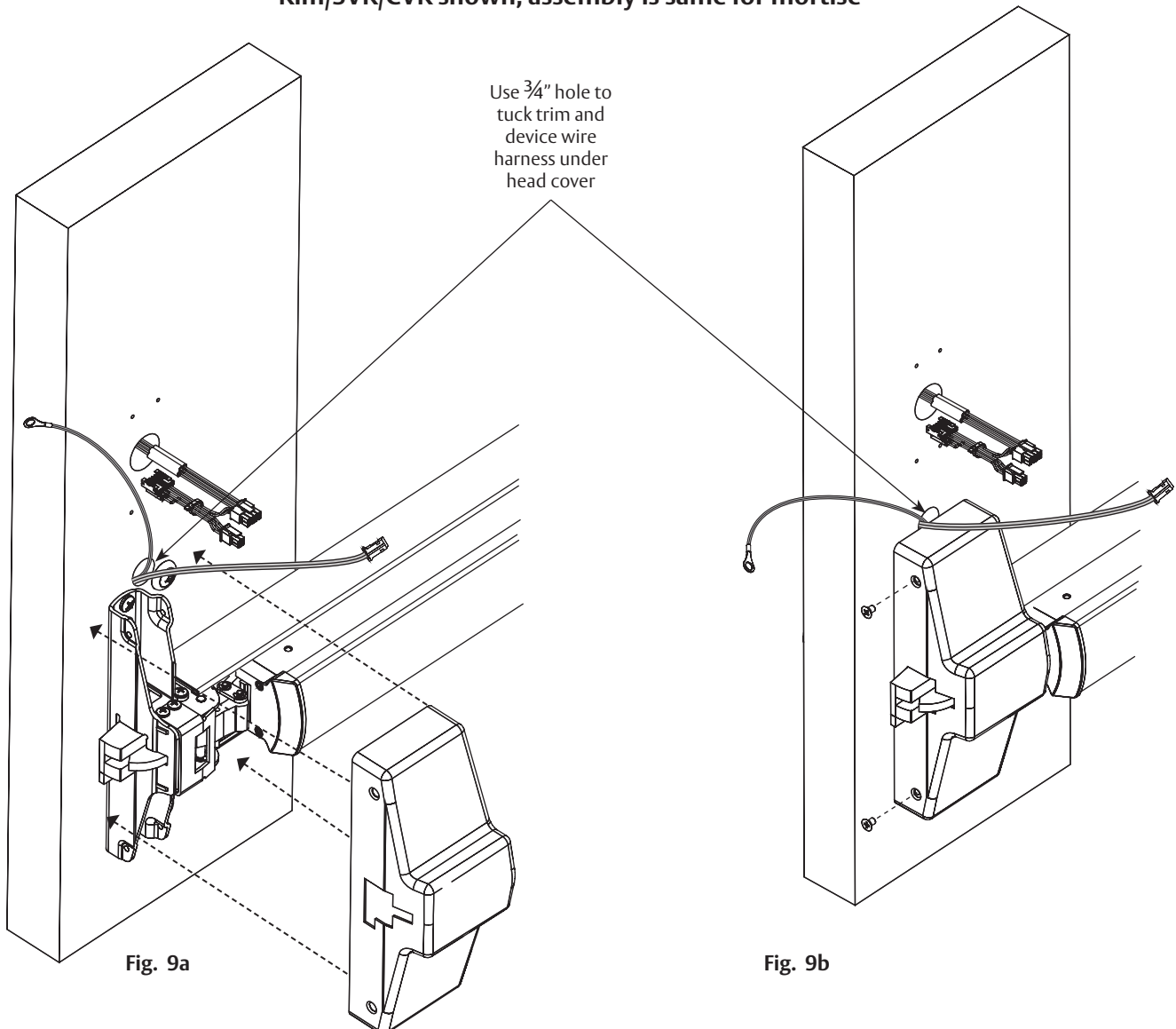

6) Installation Instructions (Continued)

10. Install Mounting Plate:

- a. Feed reader harness through mounting plate (Fig. 10a, b).
- b. For Rim, CVR and Mortise:
Begin to secure mounting plate to inside door surface by fastening (2) Phillips flat head machine screws to lower right and left holes on mounting plate (Fig. 10a).
- c. For SVR:
Secure mounting plate to inside door surface by fastening (2) Phillips flat head machine screws to holes on mounting plate (Fig. 10b)

Configuration for Rim/CVR/Mortise

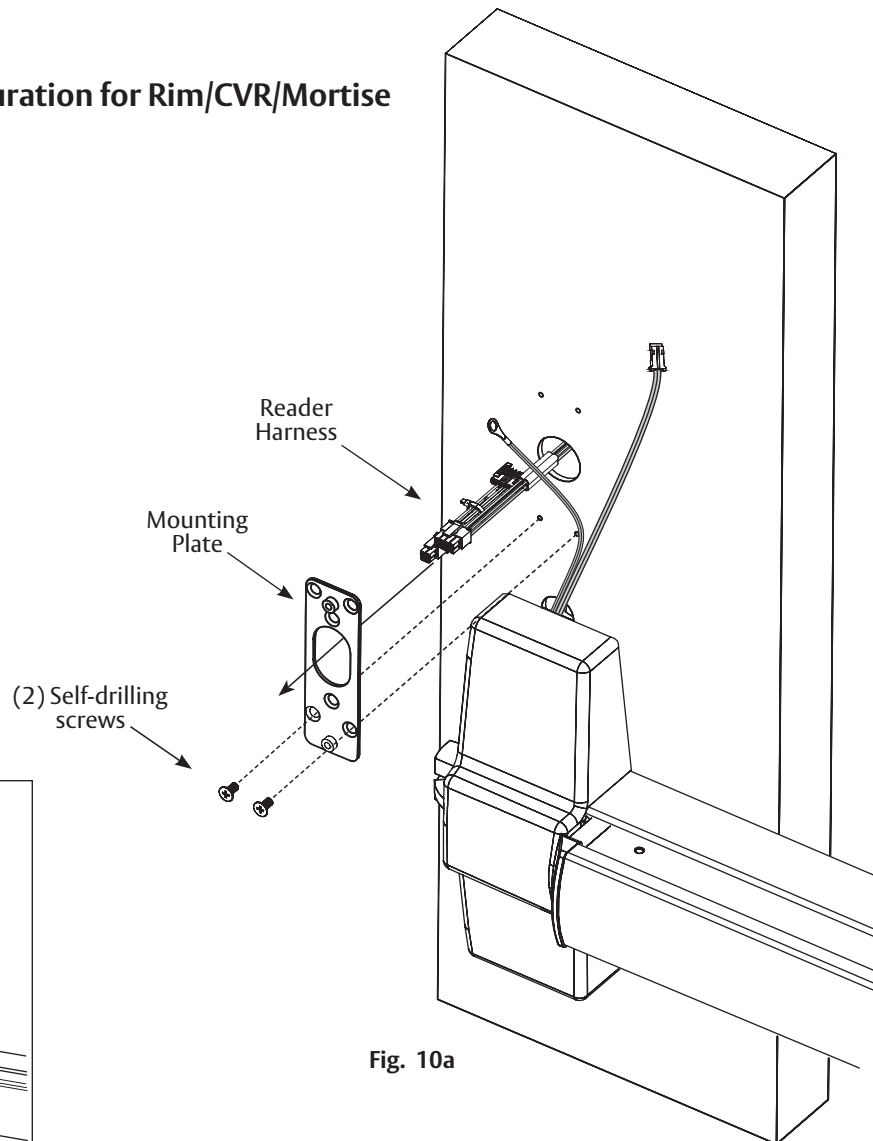

Configuration for SVR

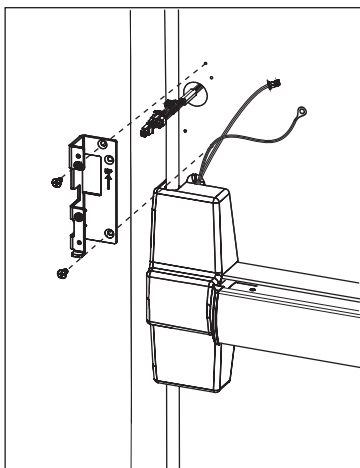

6) Installation Instructions (Continued)

11. Connector Attachments:

- a. Connect 6-pin connector from exit device to 6-pin connector on reader harness (Fig. 11a, b).
- b. Connect 2-pin connector from exit device to 2-pin connector on reader harness (Fig. 11a, b).

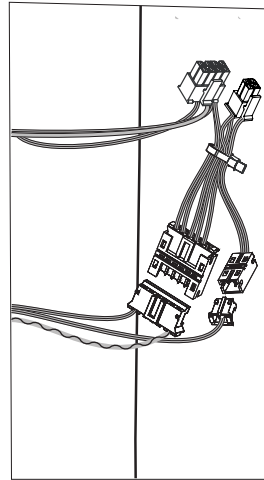

Fig. 11a

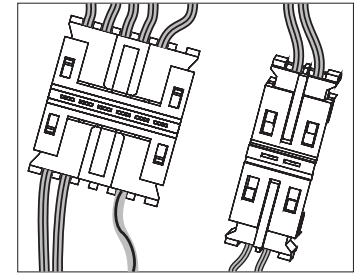

Fig. 11b

For the following refer to [page 7](#) for ElectroLynx door harness and lock interface:

- c. Connect ElectroLynx 4- and 8-pin connectors from the door harness to (black) 4- and 8-pin connectors of the reader harness (Fig. 11c).

Carefully tuck connected harnesses into one-inch hole in door.

NOTE: Neatly fold the wires into the remaining space to prevent pinching wires when mounting inside escutcheon.

Do not offset connectors and be sure they are completely seated.

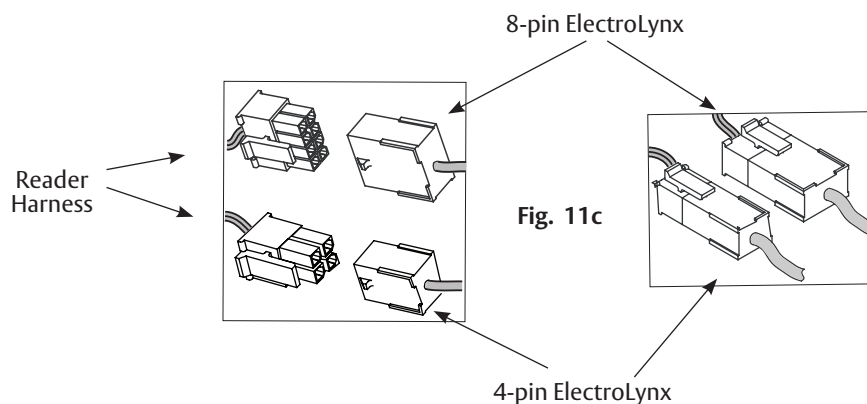

Fig. 11c

6) Installation Instructions (Continued)

12. Install Mounting Plate and (optional) Fire Plate:

- NOTE: For fire-rated doors only.** Secure mounting plate and fire plate using (2) #8 1-1/4" Phillips pan head self-drilling screws provided (Fig. 12a). Ensure wires from reader are properly routed under flap of fire plate.
- Secure mounting plate using (2) remaining Phillips flat head self-drilling screws provided. Ensure wires from reader are properly routed under flap of fire plate.
- Place ground wire eyelet between upper right mounting plate hole and screw when securing mounting plate (and fire plate if used) to door (Fig. 12a, b).

Configuration for Rim/CVR/Mortise

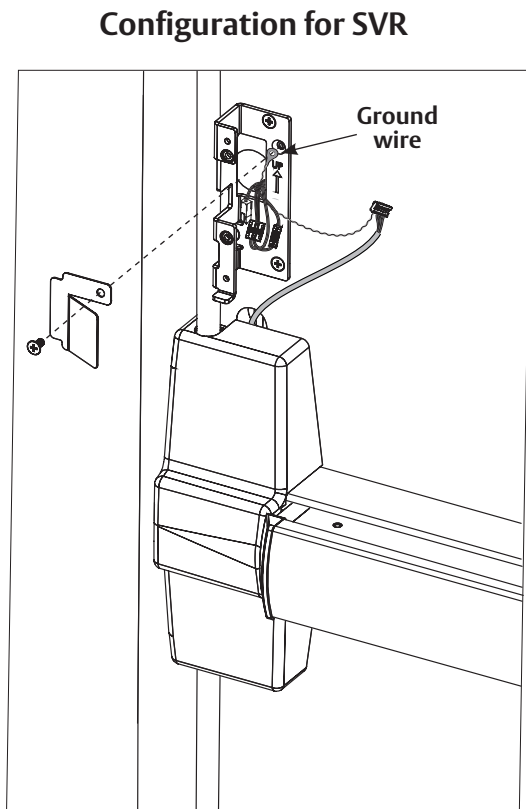

Fig. 12c

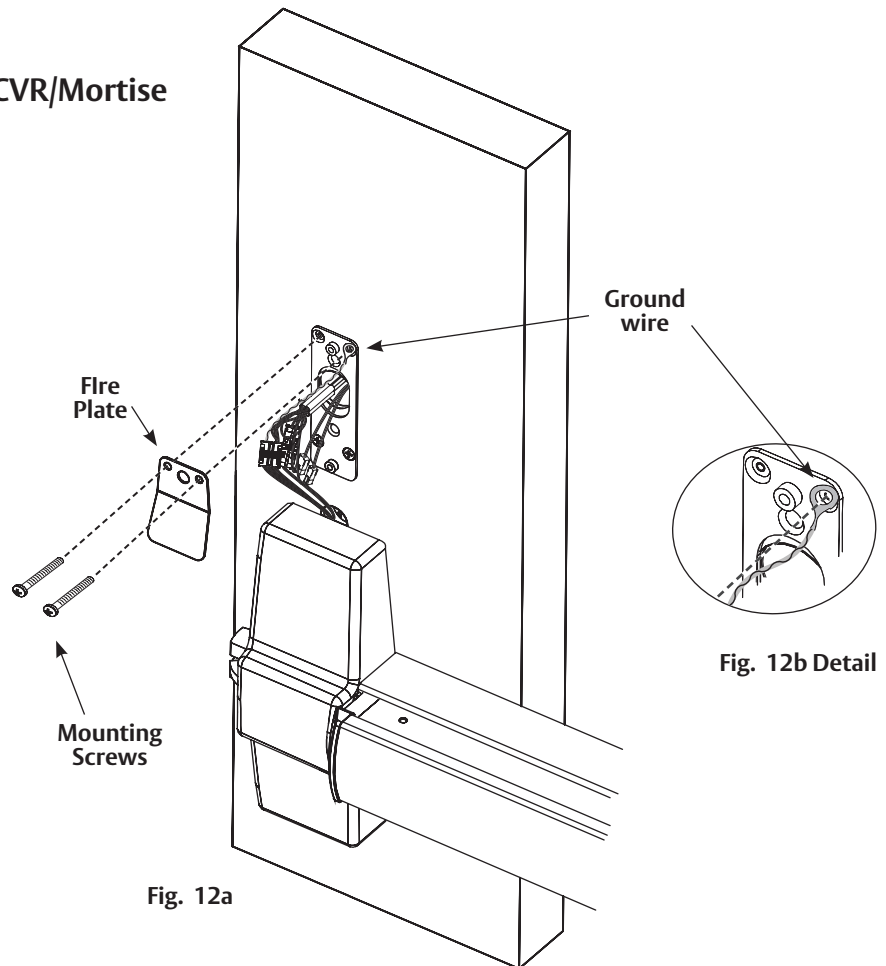

Fig. 12a

For non-fire rated door, use #8-5/8" Phillips pan head screws (no fire plate required).

6) Installation Instructions (Continued)

13. Install Inside Escutcheon:

Check electrical connections.

- Feed excess ElectroLynx wire harness back into door.
- Feed excess trim and exit device harnesses under head cover.
- Install inside escutcheon using (2) #8-32 x 5/8" oval head screws (Fig. 13a).

Note: Be careful not to pinch wires between escutcheon and door surface.

CAUTION:

- Neatly fold wires onto themselves and into the remaining space to prevent pinching wires when mounting escutcheon.

Configuration for SVR

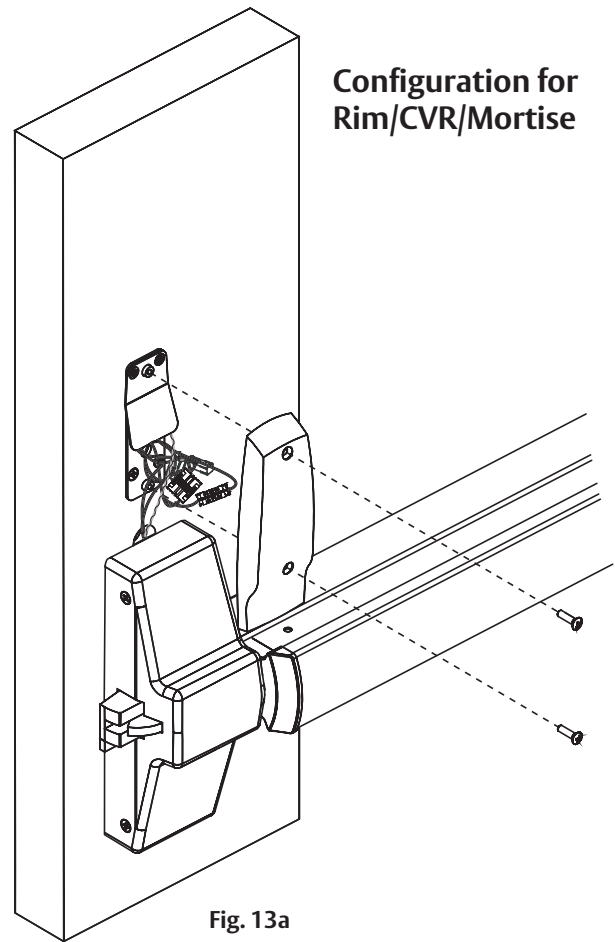
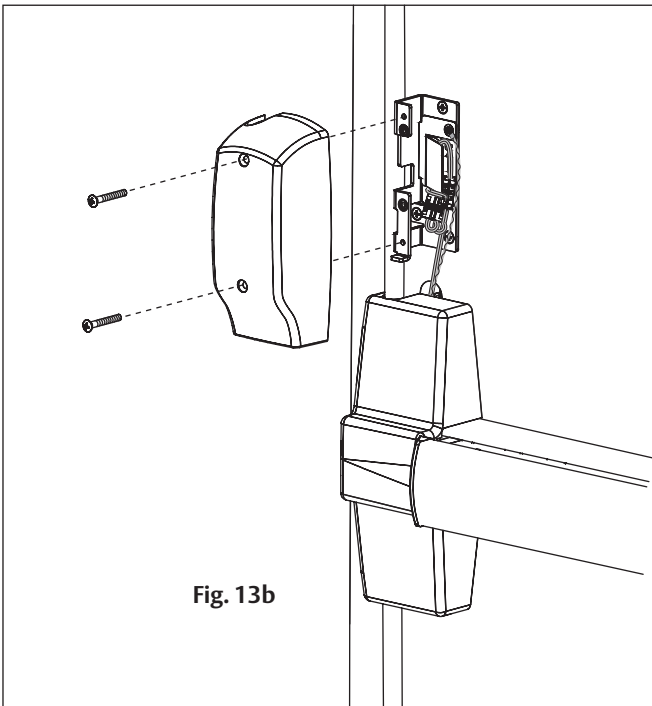

7) MELR Exit Device Configuration and Operational Check

Configuration Check

- Do not install the end cap until electrical operation is verified in order to confirm LED signaling.
- Do not discard the end cap and hardware.

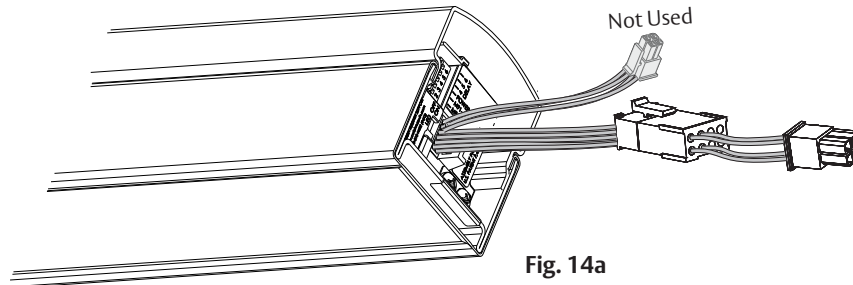

- Locate controller at end of rail (Fig. 14a).
- Ensure 'Power Mode' is set to ON as shown in Detail 14b.

NOTE: For more information, refer to FM434A MELR Exit Devices Installation & Wiring Instructions.

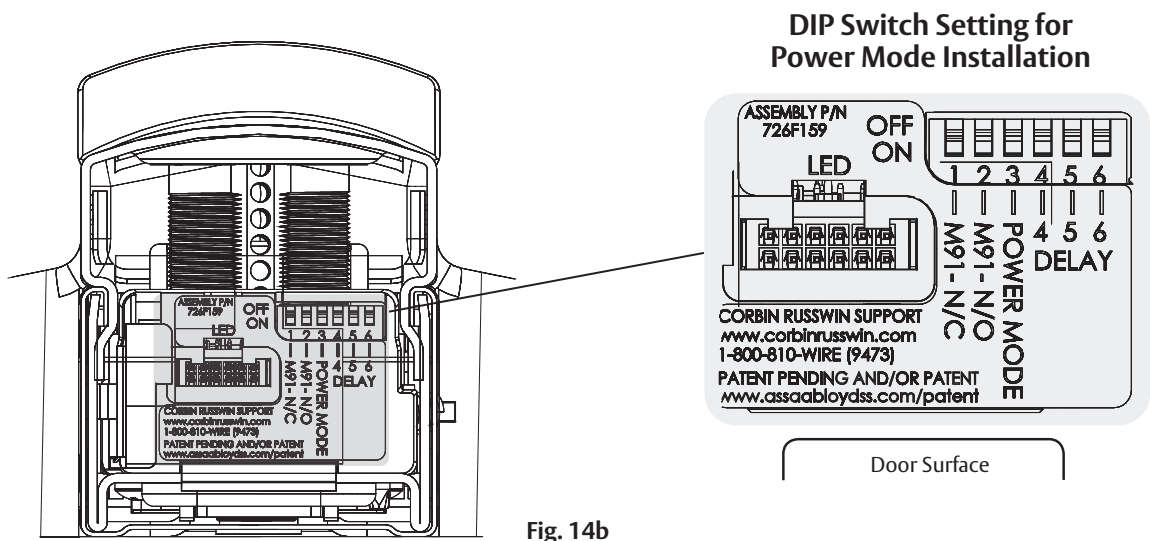

>> Reference Section 6 - Wiring Diagrams for wiring device to EAC panel <<

8) Door Position Switch Installation

- a. Install Door Position Switch supplied with product:
 - Drill 1" hole in door for magnet
 - Drill 1" hole in frame for switch
- b. Wire to ElectroLynx frame harness as shown in wiring diagram on previous page.

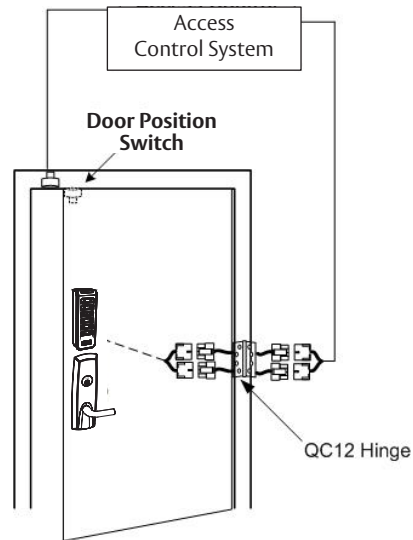

9) Operational Check

Wiegand Test Unit

The ASSA ABLOY Wiegand Test Unit verifies your installation in the field*. The test unit checks for:

- proper wiring
- card reader data integrity
- lock functionality including lock/unlock, door position status, and request-to-exit (REX) status

In addition, this tool provides demonstration abilities to highlight the product's features and capabilities**.

Feature	WT1	WT2
12 or 24VDC solenoid lock voltage adjustable	X	X
Operates as Fail Safe or Fail Secure	X	X
"Learn" mode allows testing of specific cards without programming at panel level	X	X
Card reader data integrity is validated at test unit	X	X
Displays detailed Wiegand data, including hexadecimal string and total bits received		X
Displays measured end-of-line resistor values (if applicable)		X
Displays key-press data from keypad readers†		X

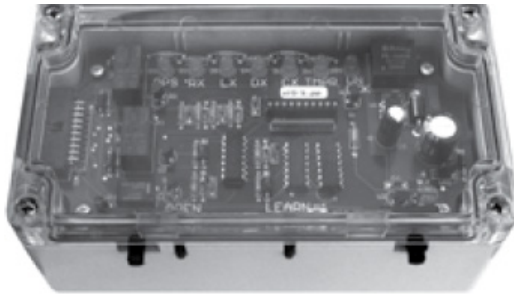

Wiegand Test Unit - WT1



Wiegand Test Unit - WT2

*For directions on use, see operating instructions provided with unit.

**SN200/210 keypad version works only with WT2

† WT2 unit with 1.03 firmware or later is required

The SNT1 is an adapter harness assembly that connects and converts OSDP lock signaling to work with a Wiegand Test Box (WTB).

If using the OSDP adapter, the WT1 will unlock on credential read or any key press, regardless of what credential is learned (OSDP reader only).

When connected to a Wiegand reader or using OSDP adapter: the WT2 will unlock on credential read and display credential value. Credentials can be learned, as usual. Individual key press will be displayed for any key press, but they cannot be learned.

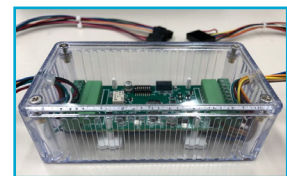

(SNT1) WTB OSDP adapter wiring harness

10) Operational Check (Continued)

Note: Once electrical wiring has been successfully completed according to proper application, perform the following steps:

- a. Ensure lock is interfaced with Wiegand Test Unit to verify installation and wiring up to (frame side) point of hinge.
- b. Turn power ON.
- c. Wait for LED to turn RED and then present compatible credential and verify LED and sounder activity.
- d. Verify valid card read on Wiegand Test Unit or at the EAC panel.
- e. Verify system operation functions; i.e., when credential is presented to reader, the door should unlock.

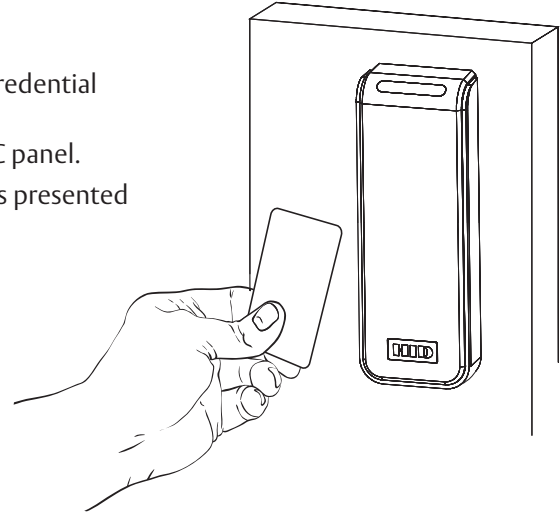

NOTE: Ensure LED operates as configured:

- LED remains green when panel asserts GREEN_LED signal or issues OSDP command

If the lock fails to operate when DC voltage is applied:

- A. Remove power.
- B. Confirm the polarity of the supply (i.e., '+' is positive).

If the lock is functioning opposite to the desired fail-safe or fail-secure operation:

- A. Remove power and check the "Fail" condition by attempting to rotate the outside lever (e.g. if fail-secure, the outside lever should be rigid with power removed).
- B. If the function is incorrect, remove the lock and repeat section 6, step 3 (DIP Switch configuration).

Installation Instructions
SN200/210 ED5000 Series Exit Device
With MELR



The ASSA ABLOY Group is the global leader in access solutions. Every day, we help billions of people experience a more open world.

ASSA ABLOY Opening Solutions leads the development within door openings and products for access solutions in homes, businesses and institutions. Our offering includes doors, frames, door and window hardware, mechanical and smart locks, access control and service.

**Corbin
Russwin** 

ASSA ABLOY

Corbin Russwin
225 Episcopal Road
Berlin, CT 06037
Phone: 800-543-3658
Fax: 800-447-6714
corbinrusswin.com

Copyright © 2020-2023 ASSA ABLOY Access and Egress Hardware Group, Inc. All rights reserved.
Reproduction in whole or in part without the express written permission of ASSA ABLOY Access and Egress Hardware Group, Inc. is prohibited.
Patent pending and/or patent - www.assaabloydss.com/patents.
HID, iCLASS, and Edge are trademarks or registered trademarks of HID Global Corporation.

For installation assistance contact Corbin Russwin
1-800-810-WIRE (9473) • techsupport.corbinrusswin@assaabloy.com

FM563 01/23