

**Notes:**

1. This template is an addition to the device template. Locate centerlines using horizontal and vertical references on device template.
2. Do not scale drawing.
3. Dimensions are in inches (mm).
4. RHR door shown. Preparation is typical for both door hands.
5. For door reinforcement see template T30800.
6. Prepare mounting holes when installing trim.
7. Provide adequate internal support to prevent door deformation after trim is bolted to the device.
8. Dimensions given about a centerline are symmetrical.

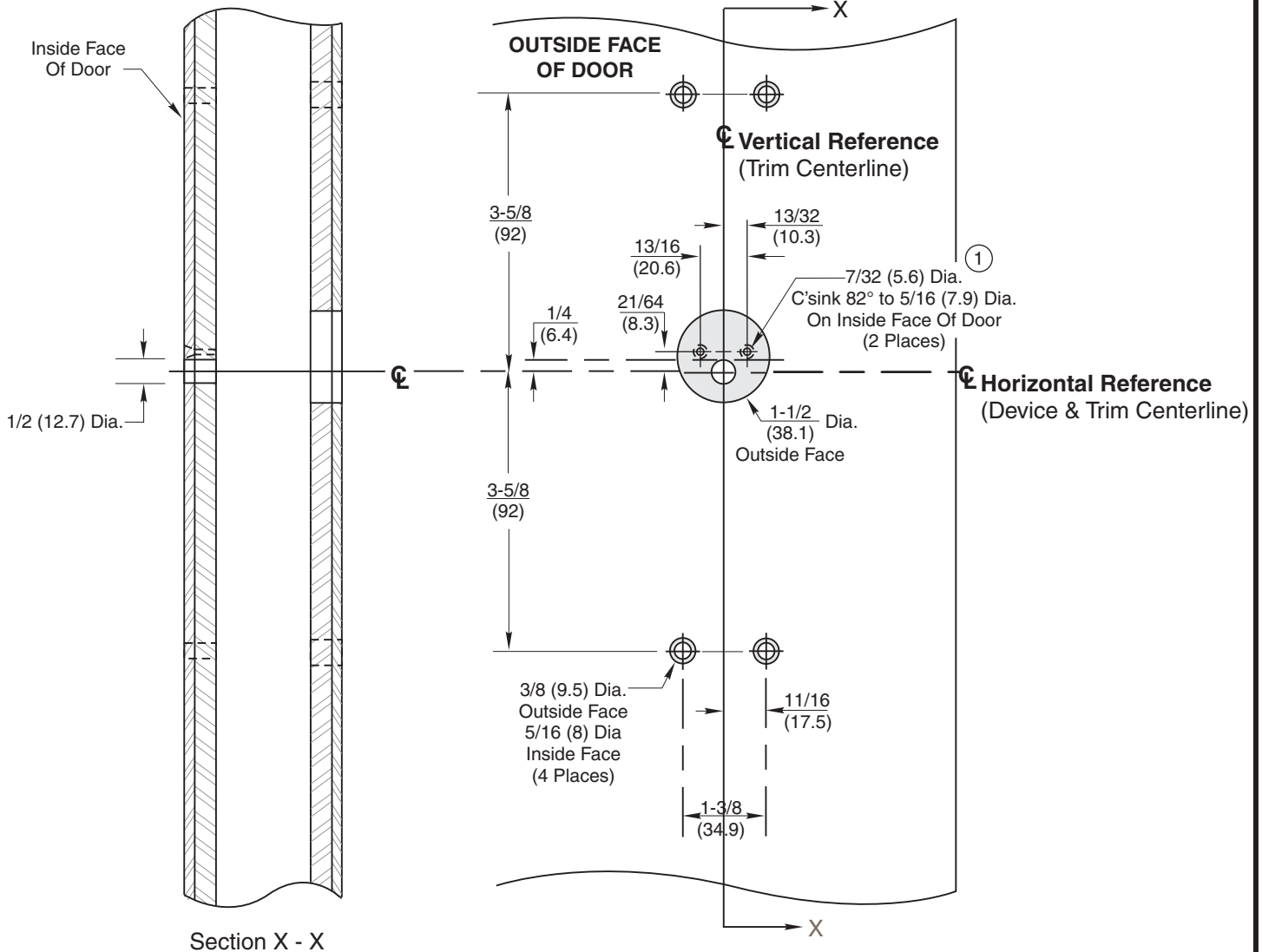

**VT957 & VTL957 Series Trim**  
 With ED5200, ED5400 or ED5800 Series  
 Rim, SecureBolt™, and Vertical Rod Exit Devices  
**Metal Door Preparation**

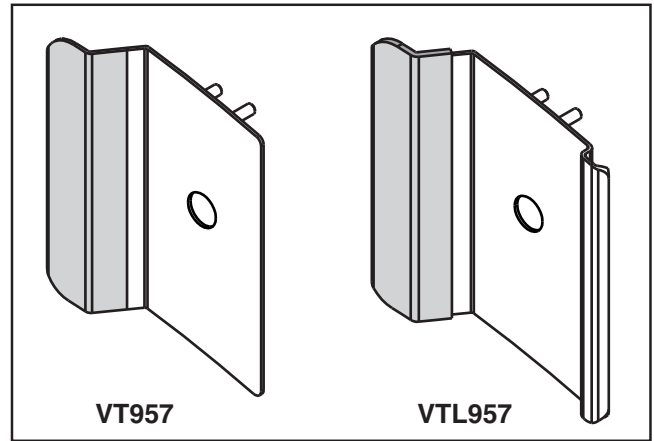

**ASSA ABLOY**

www.corbinrusswin.com

SUPERSEDES	T31088	DO NOT SCALE DRAWING
TEMPLATE NUMBER	T31088-1	DATE 08-09