

SARGENT®

ASSA ABLOY

degree[®]

Degree[®] Key System

Technical Manual



Table of Contents

Degree® Key System Technical Manual



Table of Contents

The Degree® Advantage	3
DG1 Key Cuts	4
DG2 & DG3 Key Cuts	5
Key Cutting Machines	6
Pinning Formula	7
Construction Master Keying (21-Option)	8
Visual Key Control Tamper Proof Packaging	9
Degree Pin Kits	10
Cylinder Parts: DG1-34 Rim/ DG1-40 Series Mortise	11
Cylinder Parts: 50-DG1-40 Series Mortise - Hotel Function	12
Cylinder Parts: DG2-34 Rim/ DG2-40 Series Mortise	13
Cylinder Parts: DG3-34 Rim/ DG3-40 Series Mortise	14
Cylinder Parts: DG1-6300 LFIC Cores	15
Cylinder Parts: DG2-6300 LFIC Cores	16
Cylinder Parts: DG3-6300 LFIC Cores	17
Cylinder Parts: DG1 Bored, Auxiliary, & Integrallock	18
Cylinder Parts: 50-DG1 Bored - Hotel Function	19
Cylinder Parts: DG2 Bored, Auxiliary, & Integrallock	20
Cylinder Parts: DG3 Bored, Auxiliary, & Integrallock	21

Copyright © 2013-2019, Sargent Manufacturing Company, an ASSA ABLOY Group company. All rights reserved.
Reproduction in whole or in part without the express written permission of Sargent Manufacturing Company is prohibited.

On The Cover

DG1-41 Mortise cylinder, Degree Key
and Degree DG1-6300 series core

90726 06/19

The Degree Key System

The patented Degree system from SARGENT provides the right level of security for each opening in your facility. Three levels of ANSI/ BHMA Grade 1 protection, from patented keyway to UL437 certified, secures every opening. A common key for all three levels of security enhances key control and simplifies administrative procedures. Key blanks are controlled through authorized distribution and geographical protection is available. Available for mortise, rim, component and Large Format Interchangeable Core (LFIC) cylinders, SARGENT offers the right Degree of protection for every door in your facility.

Benefits

- Patent protection from unauthorized key duplication through 2027
- New keyway family protects system integrity from legacy systems
- Keys are significantly stronger than competitive systems
- User-friendly design with minimal components provides easy field service
- Availability in all existing SARGENT cylinder types provides cost-effective upgrade for SARGENT facilities
- Bump resistance for added protection

Degree Level 1 (DG1) features a utility patented keyway and provides protection against bumping for mortise, rim and component fixed cylinders. These cylinders easily retrofit into existing hardware and are appropriate for most applications. The keys for DG1 can only open DG1 cylinders.

Degree Level 2 (DG2) builds on the utility patented keyway of DG1 and adds patented side bar locking with unique angled bottom pins that provide end users with geographical exclusivity. Cylinders provide protection against bumping and picking. Because of its superior key control and patent protection until 2027, DG2 products are recommended for use in conjunction with DG3 for new installations or when retrofitting systems, including large format interchangeable core systems.

Degree Level 3 (DG3) combines the utility patented keyway and side bar locking with unique angled bottom pins that provide end users with geographical exclusivity, and adds certification to UL437. They are classified as high security because of their superior resistance to physical attack and protection against unauthorized key duplication. Because of its superior key control, patent protection until 2027, and physical strength, we recommend DG3 products for new high-security installations or when retrofitting systems, including large format interchangeable core systems. SARGENT also offers anti-vandal and high security locksets that complement DG3 cylinders for those openings most vulnerable to attack.

IMPORTANT: Sargent DG1 key systems are available with 7 depths of cut while DG2 and DG3 are only available with 6 depths of cut. DG1 systems can utilize all 7 depths in system design only if not integrated with DG2 and/or DG3 systems. If DG1 patent protection is the only requirement in the key system and there is no expectation of combining with DG2 or DG3 levels of security, then all 7 depths are available for use.

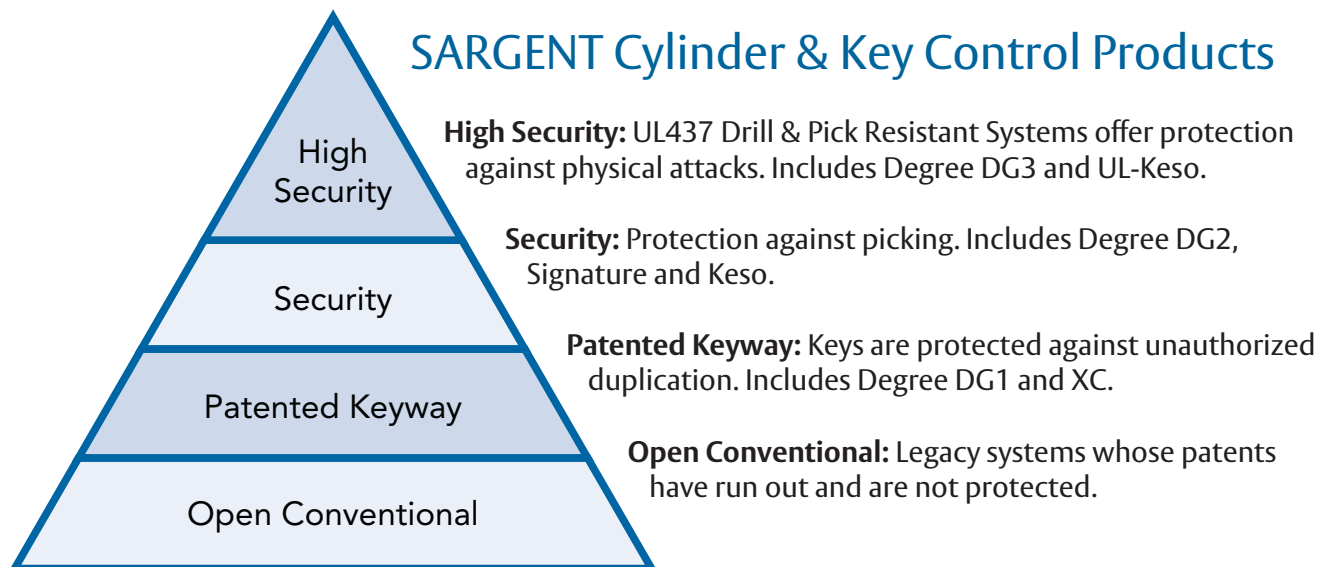

DG1 Key Cuts

Degree® Key System Technical Manual

DG1 cuts from Bow to Tip

MACF=4

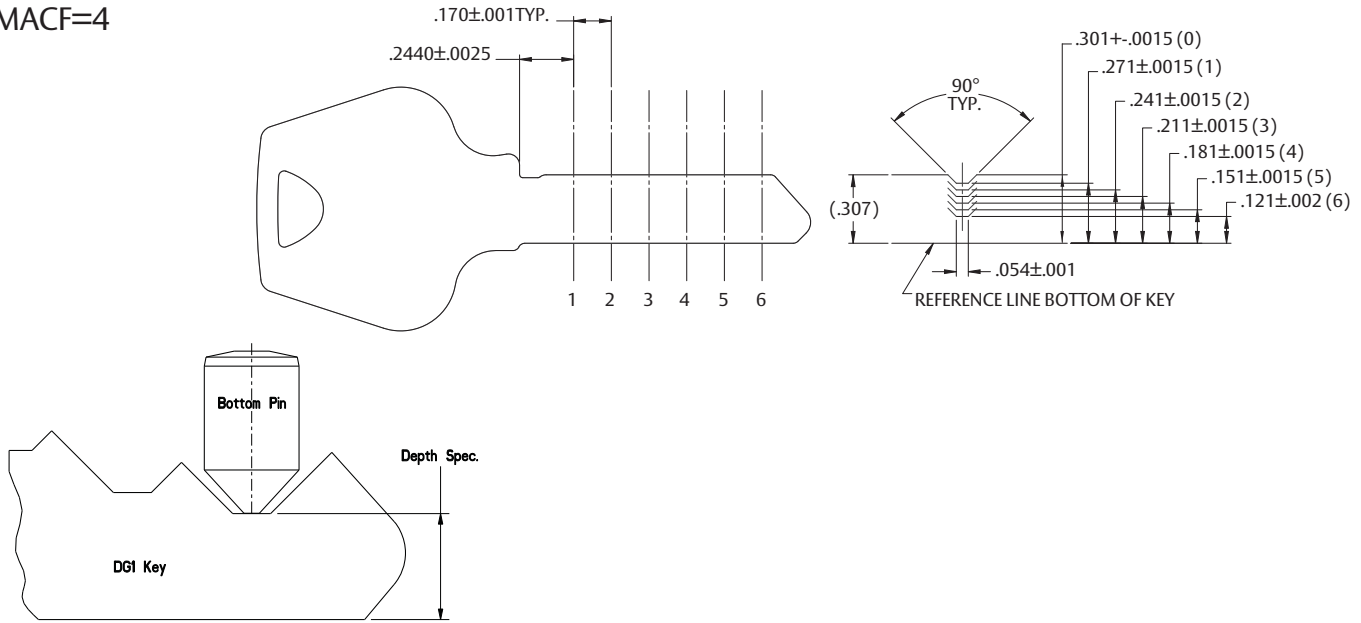

Bottom Pins (BP) for DG1- cylinders

Size #	Part No.	Length
0	DG-0027	.201
1	DG-0021	.231
2	DG-0022	.261
3	DG-0023	.291
4	DG-0024	.321
5	DG-0025	.351
6	DG-0026	.381

Driver Pins (DP) All Degree 6300 cores

Size #	Part No.	Length
1	DG-0051	.030
2	DG-0052	.060
3	DG-0053	.090
4	DG-0054	.120
5	DG-0045	.150
6	DG-0246	.180
7	DG-0247	.210
8	DG-0248	.240
9	DG-0249	.270
10	DG-0250	.300

Master Wafers (MW) for all DG- series

Size #	Part No.	Length
1	DG-0051	.030
2	DG-0052	.060
3	DG-0053	.090
4	DG-0054	.120
5	DG-0055	.150
6	DG-0246	.180

Driver Pins (DP) For all Degree Standard Cylinders

Size #	Part No.	Length
1	DG-0051	.030
2	DG-0052	.060
3	DG-0053	.090
4	DG-0054	.120
5	DG-0045	.150
6	DG-0044	.180
7	DG-0043	.210
8	DG-0042	.240
9	DG-0041	.270
10	DG-0250	.300

Control Drivers (CD) for all DG- 6300 Large Format Interchangeable Cores (3 & 4 Chambers)

Size #	Part No.	Length
1	DG-0051	.030
2	DG-0052	.060
3	DG-0053	.090
4	DG-0054	.120
5	DG-0045	.150
6	n/a	
7	DG-0247	.210
8	DG-0248	.240
9	DG-0249	.270
10	DG-0250	.300
11	DG-0251	.330
12	DG-0252	.360

Driver Pins (DP) for Bump Resistance (DG1 Fixed Core Cylinder Only)*

Size #	Part No.	Length
4	DG-0036	.120
5	DG-0035	.150
6	DG-0034	.180
7	DG-0033	.210
8	DG-0032	.240
9	DG-0031	.270
10	DG-0037	.300

*Not to be used with 6300 series Large Format Interchangeable Cores

Copyright © 2013-2019, Sargent Manufacturing Company, an ASSA ABLOY Group company. All rights reserved. Reproduction in whole or in part without the express written permission of Sargent Manufacturing Company is prohibited.

Pin diameters 0.135

DG2 & DG3 Key Cuts

Degree® Key System Technical Manual

SARGENT®

ASSA ABLOY

DG2 DG3 cuts

MACF=4

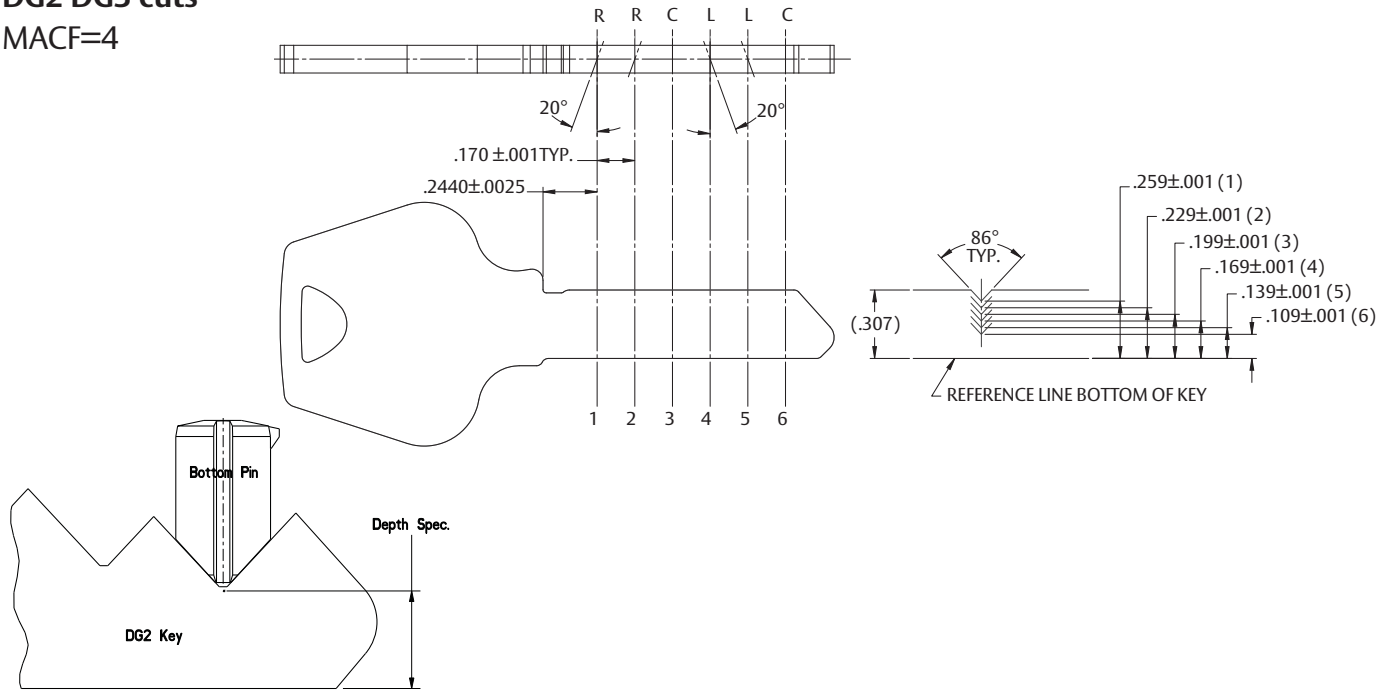

Dimensions shown are to theoretical intersection

Bottom Pins (BP) for DG2- & DG3- cylinders

First 5 positions (Angled Pins)			
Size #	Angle	Part No.	Length
1	L	DG-0111	.231
	C	DG-0121	
	R	DG-0131	
2	L	DG-0112	.261
	C	DG-0122	
	R	DG-0132	
3	L	DG-0113	.291
	C	DG-0123	
	R	DG-0133	
4	L	DG-0114	.321
	C	DG-0124	
	R	DG-0134	
5	L	DG-0115	.351
	C	DG-0125	
	R	DG-0135	
6	L	DG-0116	.381
	C	DG-0126	
	R	DG-0136	

Bottom Pins (BP) for DG2- & DG3- cylinders

6th (last) position		
Size #	Part No.	Length
1	DG-0021	.231
2	DG-0022	.261
3	DG-0023	.291
4	DG-0024	.321
5	DG-0025	.351
6	DG-0026	.381

Control Drivers (CD) for all DG- 6300 Large Format Interchangeable Cores (3 & 4 Chambers)

Size #	Part No.	Length
1	DG-0051	.030
2	DG-0052	.060
3	DG-0053	.090
4	DG-0054	.120
5	DG-0045	.150
6	n/a	
7	DG-0247	.210
8	DG-0248	.240
9	DG-0249	.270
10	DG-0250	.300
11	DG-0251	.330

Master Wafers (MW) for all DG- series

Size #	Part No.	Length
1	DG-0051	.030
2	DG-0052	.060
3	DG-0053	.090
4	DG-0054	.120
5	DG-0055	.150

Driver Pins (DP) for DG2- & DG3- cylinders and all DG- 6300 Large Format Interchangeable Cores

Size #	Part No.	Length
1	DG-0051	.030
2	DG-0052	.060
3	DG-0053	.090
4	DG-0054	.120
5	DG-0045	.150
6	DG-0044	.180
7	DG-0043	.210
8	DG-0042	.240
9	DG-0041	.270

Key Cutting Machines

Degree® Key System Technical Manual

SARGENT®

ASSA ABLOY

HPC Machines

Degree level	Key Cutting Machine	Card #	DSD#	Cutter #	Jaw
DG1	1200 (Blitz)	C389	N/A	CW-90MC	B
DG2/3	1200 (Blitz)	C390	N/A	CW-1012	DJ-1
DG1	Code Max	N/A	DSD389	CW-90MC	B
DG2/3	Code Max	N/A	DSD390	CW-1012	DJ-1
DG1	Tiger Shark	N/A	DSD389	CW-90MC	STD
DG2/3	Tiger Shark	N/A	DSD390	CW-1012	DJ-1S
DG1	Blue Shark	N/A	DSD389	CW-90MC	STD
DG2/3	Blue Shark	N/A	DSD390	CW-1012	DJ-1S

ITL Machines

Degree level	Key Cutting Machine	Vice Insert	Cutter #
DG1	9700A	3	CW-1012
DG2/3	9700A	3M3	CW-1012

Framon Machines

Degree level	Key Cutting Machine	Kit*
DG1	KX-1	KX-DG104
DG2/3	KX-1	KX-DG204

* Each kit comes complete with cam, cutter, and vice insert

Pinning Formula

Degree® Key System Technical Manual

SARGENT®

ASSA ABLOY

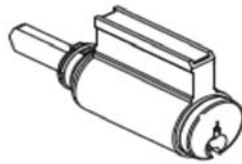

**Fixed Core Cylinders - All 6 Chambers
Large Format Interchangeable Cores
(Chambers 1-2-5-6)**



**6300 Large Format Interchangeable Core -
Control Chambers
(Chambers 3 and 4 Only)**

Non-LFIC

Driver Pin (DP)
10 MINUS
Plug Total

Master Wafer (MW) Pin =
Deepest Minus
Shallowest
Operating Cut

Bottom Pin =
Shallowest
Operating Cut

Example

Master Key	1	2	3	4	6	4
Change Key	3	4	5	2	0	2
Driver Pin (DP)	7	6	5	6	4	6
Master Wafer (MW)	2	2	2	2	6	2
Bottom Pin (BP)	1	2	3	2	0	2

Plug Total (MW + BP)

LFIC

Driver Pin (DP)
13 MINUS Plug
Total and
Control Driver

**Control
Driver (CD) =**
Control Cut PLUS 6
MINUS Plug Total

Master Wafer (MW) Pin =
Deepest MINUS
Shallowest
Operating Cut

Bottom Pin =
Shallowest
Operating Cut

Example

Control Key	1	5	5	4	3	2
Master Key	1	5	2	6	3	2
Change Key	3	1	4	3	1	5
Driver Pin (DP)	7	5	2	3	7	5
Control Driver (CD)	x	x	7	4	x	x
Master Wafer (MW)	2	4	2	3	2	3
Bottom Pin (BP)	1	1	2	3	1	2

Plug Total (MW + BP)

Instructions

Bottom Pin = shallowest operating cut
 Master Wafer (if required) = Deepest minus shallowest operating cut
 (Plug Total = Bottom Pin + Master Wafer)
 Driver Pin = 10 MINUS Plug Total

Note: "0" depth of cut only available for DG1 key systems. Not used with DG2 or DG3.

Instructions

Bottom Pin = shallowest operating cut
 Master Wafer (if required) = Deepest minus shallowest operating cut
 (Plug Total = Bottom Pin + Master Wafer)
 Control Driver (CD) = Control cut PLUS 6 MINUS Plug Total
 Driver Pin = 13 MINUS Plug Total and CD# = DP

Note: "0" depth of cut only available for DG1 key systems. Not used with DG2 or DG3.

Note: The 50-DG1 hotel mortise cylinder uses 6 pin change/master keys but with a # 5 depth cut in what would be the 7th position at the tip of the key. The 7th chamber is always loaded with a # 5 bottom pin and # 8 driver.

All other chambers are loaded as if a standard fixed core cylinder

For DG1- standard fixed cylinders use spool drivers (DG-0031 through DG-0037) in all chambers where sizes are offered for Bump Resistance.

Construction Master Keying (21- Option)

Degree® Key System Technical Manual

SARGENT®
ASSA ABLOY

Construction Master Keying (Lost/Wafer Design) for DG1-, DG2- & DG3-

SARGENT Degree cylinders when master keyed are offered with the convenience of construction keying when specified with the 21- option. This is not recommended with DG3 key systems or any system where strict key control and management is enforced.

Construction keying simplifies the process when the building gets turned over. With this feature, the 21- cylinder is master keyed with a special construction feature in one of the chambers. The plug is prepped in two places along both sides of the same chamber containing the construction feature. This allows the construction master key to be used during the construction phases.

It is highly recommended that all construction keys are collected and accounted for once the project is complete to protect the integrity of the key system. This is not recommended with DG3 key systems or any system where strict key control & management is enforced.

New systems supplied with six construction master keys unless otherwise specified. Orders to existing key systems that require additional construction keys are to be specified and ordered separately.

Orders with 21- will have all change keys shipped separately from hardware. Six construction master keys provided per system unless otherwise specified.

The 21- is not available with hotel function cylinders or large format interchangeable cores (6300 series). If construction keying is required for LFIC, specify 64-DG- construction keyed cores.

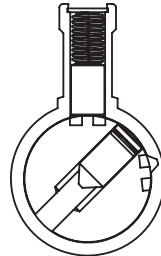
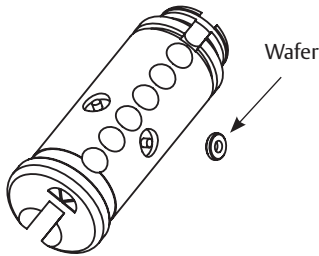

Cutaway cylinder showing construction master key being used, putting the wafer below the shear line while key is turned. Note the two empty "donut" holes on either side of the chamber.

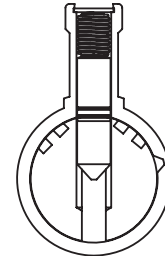

Change key inserted in cylinder putting the wafer at the shear line.

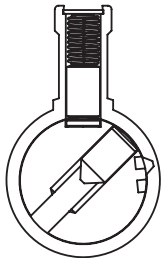

As change key rotates, construction wafer falls into "donut" hole in the side of plug. Only construction wafer will fall due to hole through its center. This voids the construction feature.

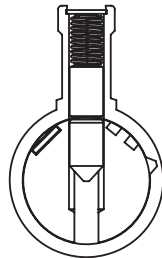

Change key rotated to position for extraction.

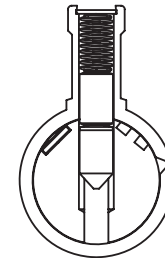

Construction key inserted after wafer is trapped. Driver now extends into plug chamber. Construction key if used will not rotate.

Copyright © 2013-2019, Sargent Manufacturing Company, an ASSA ABLOY Group company. All rights reserved. Reproduction in whole or in part without the express written permission of Sargent Manufacturing Company is prohibited.

Visual Key Control Tamper Proof Packaging

Degree® Key System Technical Manual

SARGENT®

ASSA ABLOY

Visual Key Control (Stamping)

To allow for easier key and cylinder identification, SARGENT offers permanent stamping of keys and/or optional cylinder concealed stamping with industry standard alpha-numeric key set symbols.

All DG keys are stamped with key set symbol and “DO NOT DUPLICATE” as standard.

All DG master and control keys are stamped with the key set symbol and the key system register # cylinders as standard, (Item B) unless alternate stamping is requested on the order.

Master level keys do not include bitting numbers. Master level keys include system register numbers stamped on the first line and the standard visual key control designations on the second line (Item B).

Change keys have one line for up to 7 characters for key set stamping available for permanent Visual Key Control

- Key and cylinder identified by industry standard alpha-numeric keyset symbols
- Cylinder-slide stamping available on mortise, rim, LFIC and all bored cylinders except for 8-Line and 7600 (Items C, D, & E)
- Core side engraving available for 8-Line and 7600 (Item F)

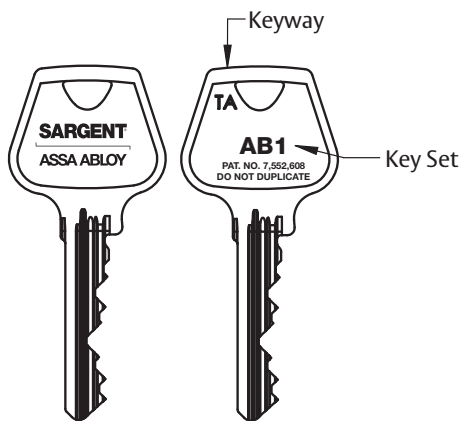

Item A
Change (Day)
Key Stamping

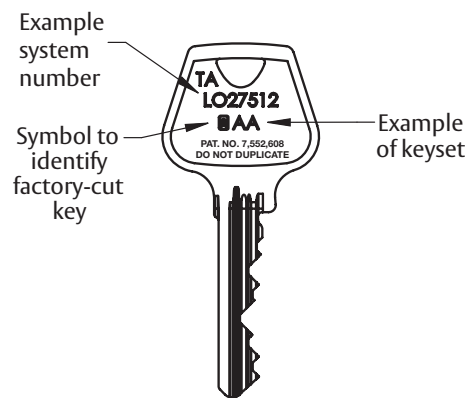

Item B
Master Level
Key Stamping



Item C

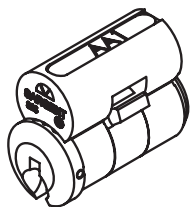

Item D

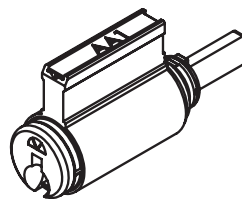

Item E

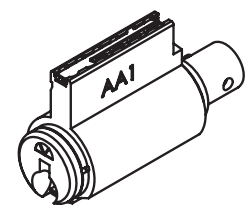

Item F

Tamper Proof Packaging

For the highest level of security for the end user, tamper proof packaging is used on all Degree master keys and key blanks. This heat sealed shrink wrap identified with “SARGENT Sealed For Your Security” provides assurance of the integrity of the factory generated key system.

437 DG1 Standard Pinning Kit

The 437 DG1 Kit is used to pin DG1 fixed and LFIC cylinders. The heavy duty steel kit prevents pins from mixing.

The kit includes:

- 100 each of bottom pins sizes 0-6
- 100 each of control drivers sizes 1-12
- 100 each of driver pins sizes 1-10
- 100 each of bump resistant pins sizes 4-10
- 25 sidebar springs part number DG-0059
- 100 KIK spring cover part number 13-1341
- 25 KIL/MRT/RIM/LFIC spring cover DG-0040
- 10 each Sidebar (LFIC only) part number DG-2818
- 100 each compression spring part number DG-0017
- 100 each compression spring (LFIC only) part number DG-0097
- Tweezer
- DG1 key key gauge part number 435DG

See pages 4 and 5 for individual pin part #s.

The kit has additional empty compartments for future upgrades to DG2 and DG3 cylinders.

The 437 DGM "Master Kit" has all pins needed for pinning DG1, DG2 and DG3 cylinders.



437 DGM Master Shown

437 DGM Master Pinning Kit

The 437 DGM "Master Kit" includes all pins needed to re-pin DG1, DG2 and DG3 cylinders.

Kit includes all the same components as in the 437 DG1 kit, with the additional parts to service DG2 and DG3 cylinders.

- 10 each Side bar part number DG 0056
- 25 each slider spring part number DG 0060
- 100 each of Left, Center and Right "Chisel Bottom Pins" sizes 1 thru 6

See pages 4 and 5 for individual part numbers.

Cylinder Spray Lubricant

Degree cylinders are mechanical devices and require preventive maintenance. At a minimum, Degree cylinders should be lubricated twice a year; more if installed in extreme installations.

Degree cylinders should not be exposed to chemical washes or painted.

3.0 oz aerosol part number 18-0070.

Cylinder Spray Cleaner/Deicer: 3.0 oz aerosol part number 18-0435.

Cylinder Parts: DG1-34 Rim/ DG1-40 Series Mortise

Degree® Key System Technical Manual



DG1-34 Rim/ DG1-40 Series Mortise Cylinder Parts

Item	Description	Part Number	Where Used / Cylinder Length		Comment
1	Plug	DG-2894	DG1-34	-	Plug finishes: 04, 15
		DG-2911	DG1-41 & 78-DG1-41	1-1/8" (29mm)	
		DG-2912	DG1-42 & 78-DG1-42	1-1/4" (32mm)	
		DG-2913	DG1-43 & 78-DG1-43	1-3/8" (35mm)	
		DG-2914	DG1-44	1-1/2" (38mm)	
		DG-2915	DG1-46	1-3/4" (44mm)	
2	Cylinder Shell	DG-0621	DG1-41 & DG1-34	1-1/8" (29mm)	Shell finishes: 03, 04, 09, 10, 10B, 10BE, 10BL, 14, 15, 20D, 26, 26D, BSP, WSP
		DG-0622	DG1-42	1-1/4" (32mm)	
		DG-0623	DG1-43	1-3/8" (35mm)	
		DG-0624	DG1-44	1-1/2" (38mm)	
		DG-0625	DG1-46	1-3/4" (44mm)	
		DG-0221	78-DG1-41	1-1/8" (29mm)	No finish. For use with mortise locks with LE3 or LE4 trim only.
		DG-0222	78-DG1-42	1-1/4" (32mm)	
		DG-0223	78-DG1-43	1-3/8" (35mm)	
3	Conical Bottom Pin	See Page 4 and 5	DG1-40 Series Mortise & DG1-34 Rim		
4	Master Wafer	See Page 4 and 5	DG1-40 Series Mortise & DG1-34 Rim		
5	Bump-Resistant Driver Pin	See Page 4 and 5	DG1-40 Series Mortise & DG1-34 Rim		
6	Compression Spring	DG-0017	DG1-40 Series Mortise & DG1-34 Rim		
7	Cam	See Degree Catalog	DG1-40 Series Mortise		
8	Screw	DG-0016	DG1-40 Series Mortise		# 2-56 x 5/16" (8mm) PH. FL.
10	Retainer	DG-0090	DG1-34 Rim		
11	Tailpiece Retainer	DG-0195	DG1-34 Rim		
12	Tailpiece	DG-0196	DG1-34 Rim		
13	Spring Cover	DG-0040	DG1-40 Series Mortise & DG1-34 Rim		
14	Standard Connecting Screws	13-0074	DG1-34 Rim		# 12-24 x 2-1/8" (54mm)
15	Rim Cylinder Back Plate	13-0086	DG1-34 Rim		

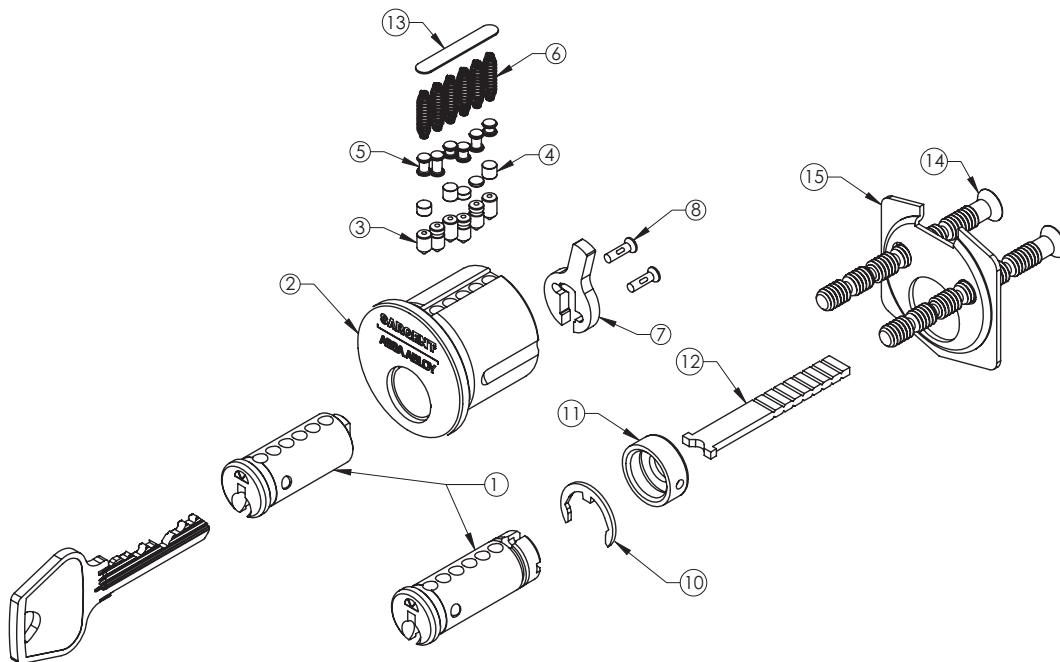

Cylinder Parts: 50-DG1-40 Series Mortise - Hotel Function

Degree® Key System Technical Manual

SARGENT®

ASSA ABLOY

50-DG1-40 Series Mortise Cylinder Parts For use with 78/8250 lock sets only

Item	Description	Part Number	Where Used / Cylinder Length		Comment
1	Plug	DG-2923	50-DG1-43	1-3/8" (35mm)	Plug finishes: 04, 15
		DG-2924	50-DG1-44	1-1/2" (38mm)	
2	Cylinder Shell	DG-0310	50-DG1-43	1-3/8" (35mm)	Shell finishes: 03, 04, 09, 10, 10B, 10BE, 10BL, 14, 15, 20D, 26, 26D, BSP, WSP
		DG-0311	50-DG1-44	1-1/2" (38mm)	
3	Hotel Function Sleeve	DG-0314	50-DG1-43	1-3/8" (35mm)	
		DG-0315	50-DG1-44	1-1/2" (38mm)	
4	Conical Bottom Pin	See Page 4 and 5	All Cylinders		7th chamber always uses #5 bottom pin
5	Master Wafer	See Page 4 and 7	All Cylinders		
6	Bump-Resistant Driver Pin	See Page 4 and 8	All Cylinders		
7	Driver Pin	DG-0042	All Cylinders		7th chamber always uses #8 driver
8	Compression Spring	DG-0017	All Cylinders		Front six pin chambers
9	Compression Spring, LFIC	DG-0097	All Cylinders		Unique to the 7th chamber only
10	Cam	DG-2808	50-DG1-43/44 cylinders only		
11	Screw	DG-0016	All Cylinders		#2-56 x 5/16" (8mm) PH. FL.
12	Spring Cover (7-pin)	DG-0038	50-DG1-43/44 cylinders only		

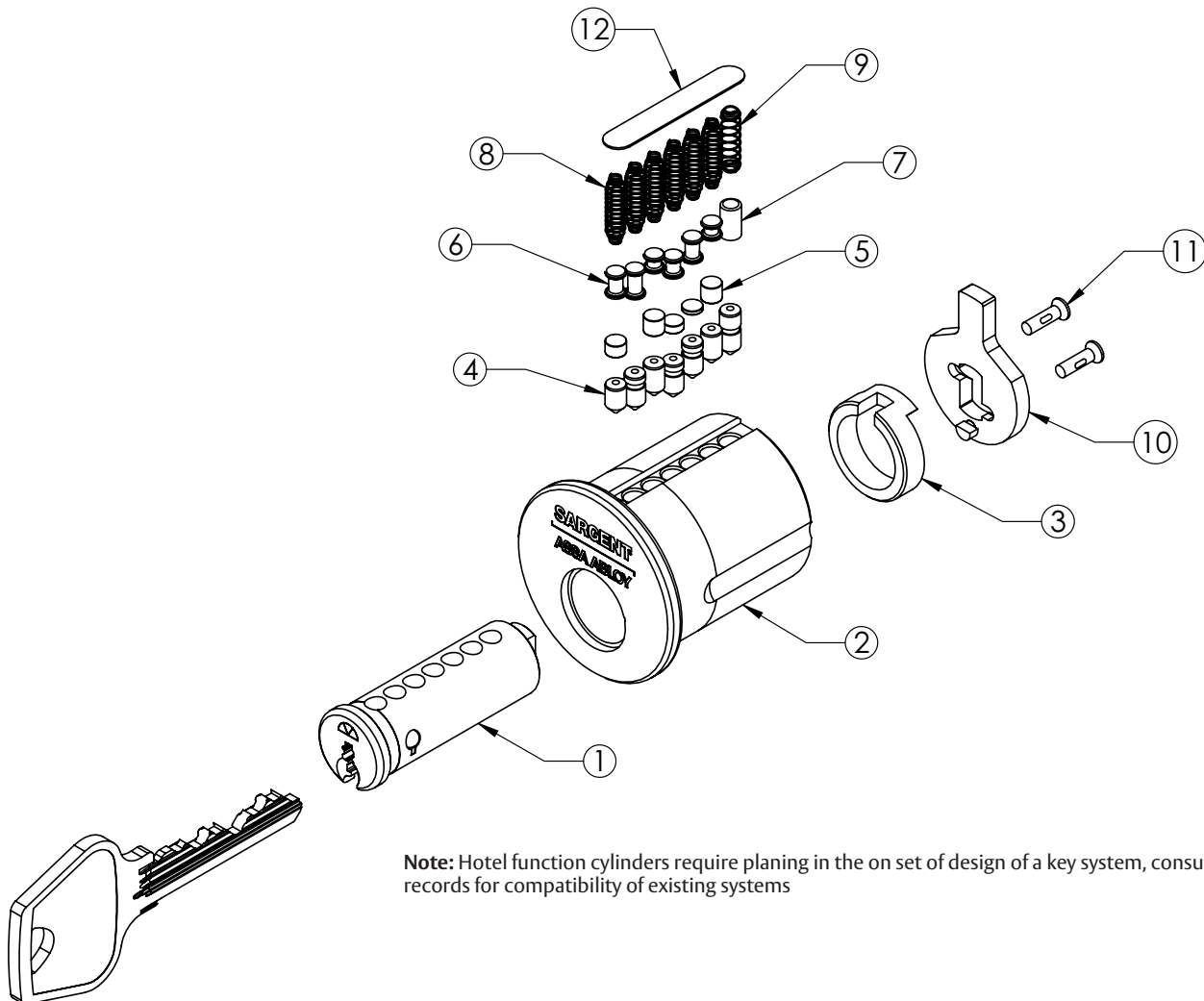

Copyright © 2013-2019, Sargent Manufacturing Company, an ASSA ABLOY Group company. All rights reserved. Reproduction in whole or in part without the express written permission of Sargent Manufacturing Company is prohibited.

90726 06/19

Cylinder Parts: DG2-34 Rim/ DG2-40 Series Mortise

Degree® Key System Technical Manual

SARGENT®

ASSA ABLOY

DG2-34 Rim / DG2-40 Series Mortise Cylinder Parts

Item	Description	Part Number	Where Used / Cylinder Length		Comment
1	Plug	DG-0191	DG2-34	-	Plug finishes: 04, 15
		DG-0411	DG2-41 & 78-DG2-41	1-1/8" (29mm)	
		DG-0412	DG2-42 & 78-DG2-42	1-1/4" (32mm)	
		DG-0413	DG2-43 & 78-DG2-43	1-3/8" (35mm)	
		DG-0414	DG2-44	1-1/2" (38mm)	
		DG-0415	DG2-46	1-3/4" (44mm)	
2	Cylinder Shell	DG-0631	DG2-41 & DG2-34	1-1/8" (29mm)	Shell finishes: 03, 04, 09, 10, 10B, 10BE, 10BL, 14, 15, 20D, 26, 26D, BSP, WSP
		DG-0632	DG2-42	1-1/4" (32mm)	
		DG-0633	DG2-43	1-3/8" (35mm)	
		DG-0634	DG2-44	1-1/2" (38mm)	
		DG-0635	DG2-46	1-3/4" (44mm)	No finish. For use with mortise locks with LE3 or LE4 trim only.
		DG-0231	78-DG2-41	1-1/8" (29mm)	
		DG-0232	78-DG2-42	1-1/4" (32mm)	
	DG-0233	78-DG2-43	1-3/8" (35mm)		
3	Chisel Tipped Bottom Pin	See Page 4 and 5	DG2-40 Series Mortise & DG2-34 Rim		In pin chambers 1 through 5
4	Conical Bottom Pin	See Page 4 and 5	DG2-40 Series Mortise & DG2-34 Rim		In pin chamber 6 only
5	Master Wafer	See Page 4 and 5	DG2-40 Series Mortise & DG2-34 Rim		
6	Driver Pin	See Page 4 and 5	DG2-40 Series Mortise & DG2-34 Rim		
7	Compression Spring	DG-0017	DG2-40 Series Mortise & DG2-34 Rim		
8	Slider C6M6	DG-0087	DG2-40 Series Mortise & DG2-34 Rim		For keys with a #6 slider cut
9	Slider Spring	DG-0060	DG2-40 Series Mortise & DG2-34 Rim		
10	Sidebar Spring	DG-0059	DG2-40 Series Mortise & DG2-34 Rim		
11	Sidebar	DG -2818	DG2-40 Series Mortise & DG2-34 Rim		
12	Cam	See Degree Catalog	DG2-40 Series Mortise		
13	Screw	DG-0016	DG2-40 Series Mortise		# 2-56 x 5/16" (8mm) PH. FL.
15	Retainer	DG-0090	DG2-34 Rim		
16	Tailpiece Retainer	DG-0195	DG2-34 Rim		
17	Tailpiece	DG-0196	DG2-34 Rim		
18	Spring Cover	DG-0040	DG2-40 Series Mortise & DG2-34 Rim		
19	Standard Connecting Screws	13-0074	DG2-34 Rim		# 12-24 x 2-1/8" (54mm)
20	Rim Cylinder Back Plate	13-0086	DG2-34 Rim		

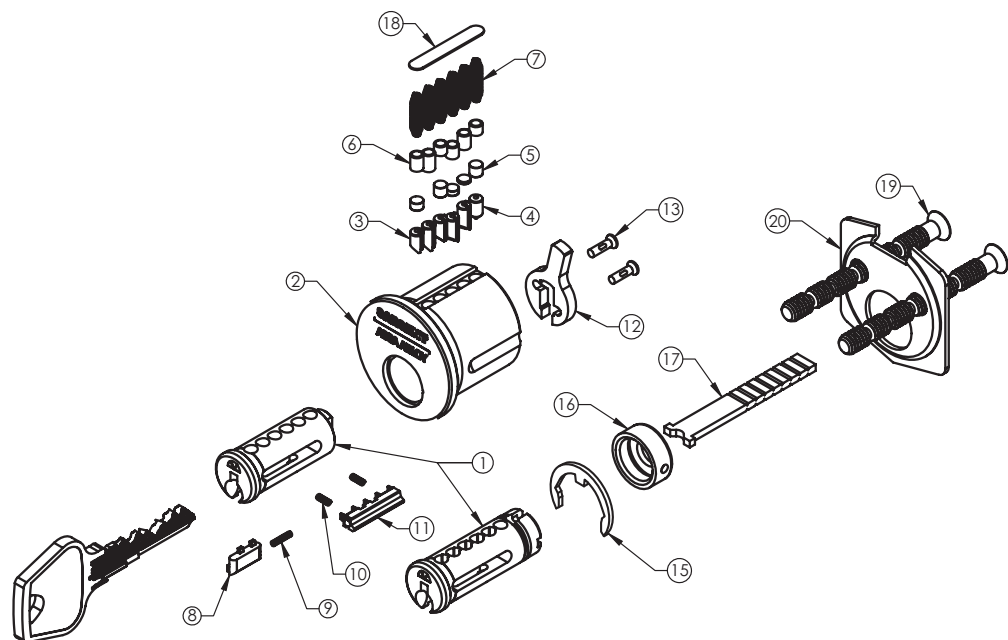

Copyright © 2013-2019, Sargent Manufacturing Company, an ASSA ABLOY Group company. All rights reserved. Reproduction in whole or in part without the express written permission of Sargent Manufacturing Company is prohibited.

Cylinder Parts: DG3-34 Rim/ DG3-40 Series Mortise

Degree® Key System Technical Manual

SARGENT®

ASSA ABLOY

DG3-34 Rim / DG3-40 Series Mortise Cylinder Parts

Item	Description	Part Number	Where Used / Cylinder Length	Comment	
1	Plug	DG-2895	DG3-34	-	Plug finishes: 04, 15
		DG-2881	DG3-41 & 78-DG3-41	1-1/8" (29mm)	
		DG-2882	DG3-42 & 78-DG3-42	1-1" (32mm)	
		DG-2883	DG3-43 & 78-DG3-43	1-3/8" (35mm)	
		DG-2884	DG3-44	1-1/2" (38mm)	
2	Cylinder Shell	DG-2885	DG3-46	1-3/4" (44mm)	Shell finishes: 03, 04, 09, 10, 10B, 10BE, 10BL, 14, 15, 20D, 26, 26D, BSP, WSP
		DG-0641	DG3-41 & DG3-34	1-1/8" (29mm)	
		DG-0642	DG3-42	1-1/4" (32mm)	
		DG-0643	DG3-43	1-3/8" (35mm)	
		DG-0644	DG3-44	1-1/2" (38mm)	No finish. For use with mortise locks with LE3 or LE4 trim only.
		DG-0645	DG3-46	1-3/4" (44mm)	
		DG-0241	78-DG3-41	1-1/8" (29mm)	
		DG-0242	78-DG3-42	1-1/4" (32mm)	
		DG-0243	78-DG3-43	1-3/8" (35mm)	
3	Chisel Tipped Bottom Pin	See Page 4 and 5	DG3-40 Series Mortise & DG3-34 Rim	In pin chambers 1 through 5	
4	Conical Bottom Pin	See Page 4 and 5	DG3-40 Series Mortise & DG3-34 Rim	In pin chamber 6 only	
5	Master Wafer	See Page 4 and 5	DG3-40 Series Mortise & DG3-34 Rim		
6	Driver Pin	See Page 4 and 5	DG3-40 Series Mortise & DG3-34 Rim		
7	Compression Spring	DG-0017	DG3-40 Series Mortise & DG3-34 Rim		
8	Slider C6M6	DG-0087	DG3-40 Series Mortise & DG3-34 Rim	For keys with a #6 slider cut	
9	Slider Spring	DG-0060	DG3-40 Series Mortise & DG3-34 Rim		
10	Sidebar Spring	DG-0059	DG3-40 Series Mortise & DG3-34 Rim		
11	Sidebar	DG-2818	DG3-40 Series Mortise & DG3-34 Rim		
12	Security Plate	DG-0057	DG3-40 Series Mortise & DG3-34 Rim	Required for UL437	
13	Cam	See Degree Catalog	DG3-40 Series Mortise		
14	Screw	DG-0016	DG3-40 Series Mortise	# 2-56 x 5/16" (8mm) PH. FL.	
16	Retainer	DG-0090	DG3-34 Rim		
17	Tailpiece Retainer	DG-0195	DG3-34 Rim		
18	Tailpiece	DG-0196	DG3-34 Rim		
19	Spring Cover	DG-0040	DG3-40 Series Mortise & DG3-34 Rim		
20	Standard Connecting Screws	13-0074	DG3-34 Rim	# 12-24 x 2-1/8" (54mm)	
21	Cylinder Back Plate	13-0086	DG3-34 Rim		

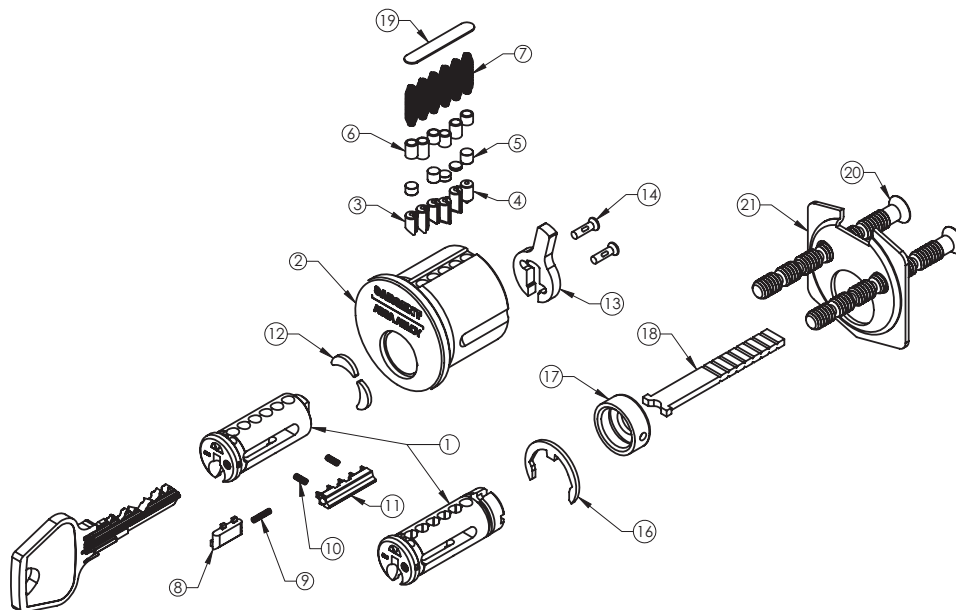

Copyright © 2013-2019, Sargent Manufacturing Company, an ASSA ABLOY Group company. All rights reserved. Reproduction in whole or in part without the express written permission of Sargent Manufacturing Company is prohibited.

Cylinder Parts: DG1-LFIC Cores

Degree® Key System Technical Manual

SARGENT®

ASSA ABLOY

DG1 LFIC Cores

Item	Description	Part Number	Comment
1	Plug	DG-0200	Plug finishes: 04, 15
2	Cylinder Shell	DG-0290	Shell finishes: 04, 15
3	Control Sleeve	DG-0215	
4	Conical Bottom Pin	See Page 4 and 5	
5	Master Wafer	See Page 4 and 5	
6	Control Pin	See Page 4 and 5	
7	Driver Pin	See Page 4 and 5	
8	Compression Spring, LFIC	DG-0097	Control Sleeve Pin Chambers Only
9	Compression Spring	DG-0017	All Other Pin Chambers
10	Plug Retainer	DG-0090	
11	Sidebar Spring	DG-0059	
12	Sidebar	DG-0056	
13	Spring Cover	DG-0040	

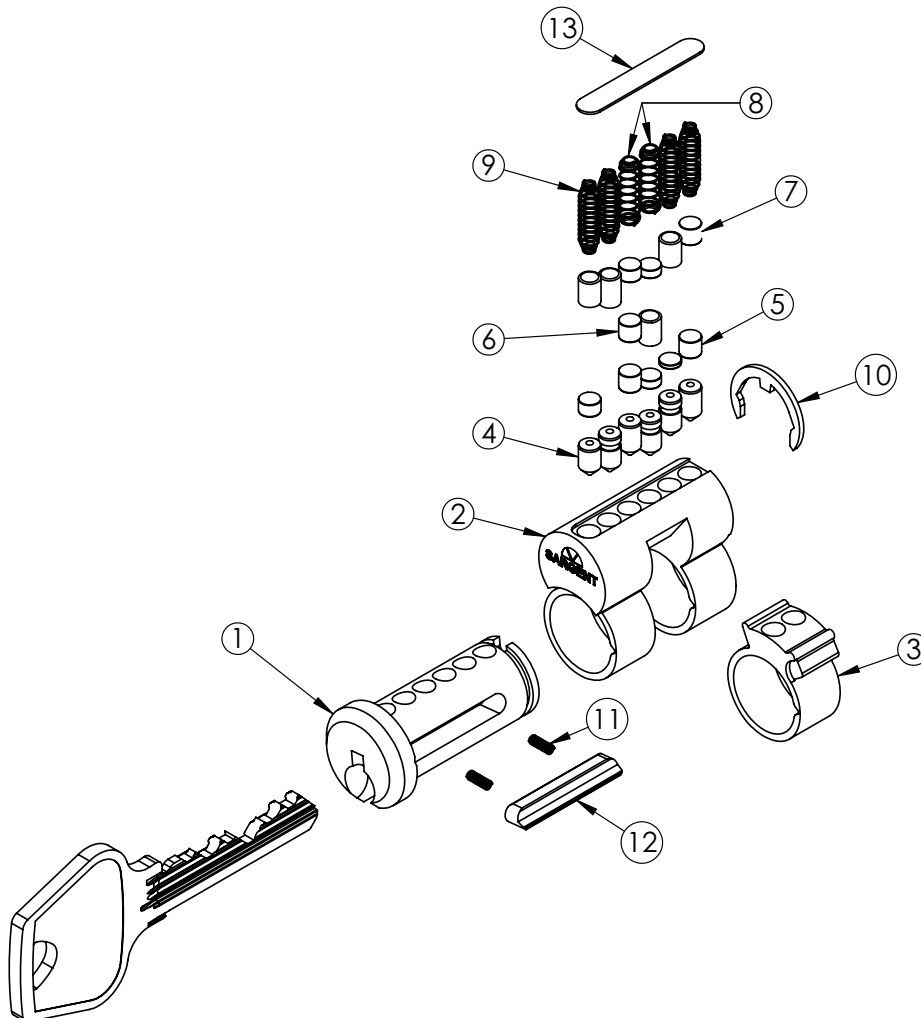

Copyright © 2013-2019, Sargent Manufacturing Company, an ASSA ABLOY Group company. All rights reserved. Reproduction in whole or in part without the express written permission of Sargent Manufacturing Company is prohibited.

DG2 LFIC Cores

Item	Description	Part Number	Comment
1	Plug	DG-0201	Plug finishes: 04, 15
2	Cylinder Shell	DG-0291	Shell finishes: 04, 15
3	Control Sleeve	DG-0216	
4	Chisel Tipped Bottom Pin	See Page 4 and 5	In pin chambers 1 through 5
5	Conical Bottom Pin	See Page 4 and 5	In pin chamber 6 only
6	Master Wafer	See Page 4 and 5	
7	Control Pin	See Page 4 and 5	
8	Driver Pin	See Page 4 and 5	
9	Compression Spring, LFIC	DG-0097	Control Sleeve Pin Chambers Only
10	Compression Spring	DG-0017	All Other Pin Chambers
11	Slider C6M6	DG-0087	For keys with a #6 slider cut
12	Slider Spring	DG-0060	
13	Sidebar Spring	DG-0059	
14	Sidebar	DG-2818	
15	Plug Retainer	DG-0090	
16	Spring Cover	DG-0040	

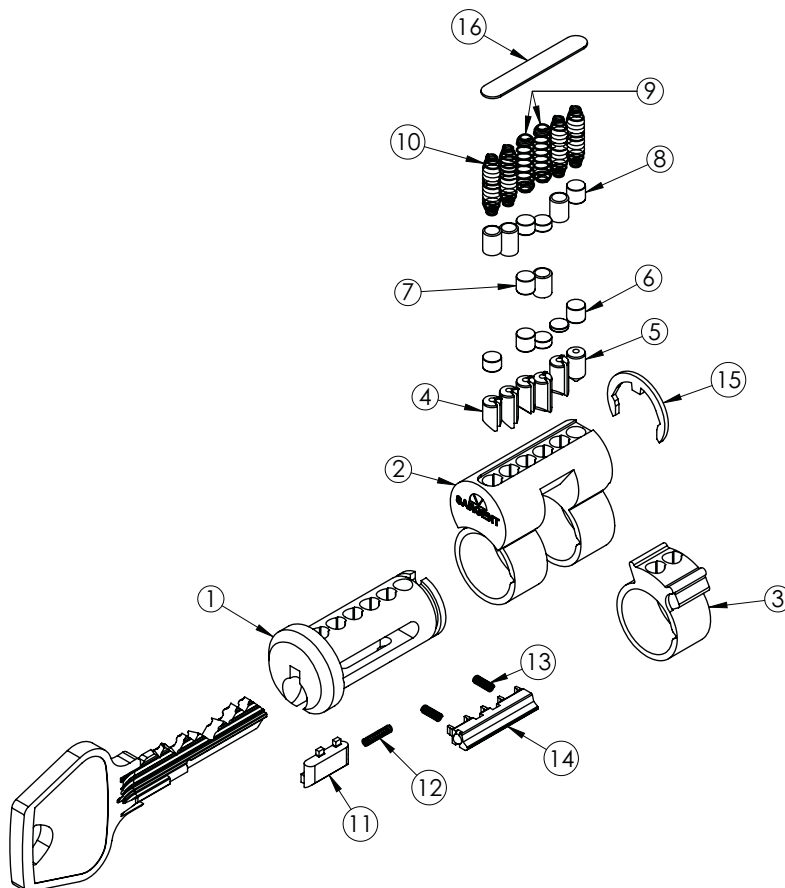

Copyright © 2013-2019, Sargent Manufacturing Company, an ASSA ABLOY Group company. All rights reserved. Reproduction in whole or in part without the express written permission of Sargent Manufacturing Company is prohibited.

Cylinder Parts: DG3-LFIC Cores

Degree® Key System Technical Manual

SARGENT®

ASSA ABLOY

DG3 LFIC Cores

Item	Description	Part Number	Comment
1	Plug	DG-2901	Plug finishes: 04, 15
2	Cylinder Shell	DG-0292	Shell finishes: 04, 15
3	Control Sleeve	DG-0216	
4	Chisel Tipped Bottom Pin	See Page 4 and 5	In pin chambers 1 through 5
5	Conical Bottom Pin	See Page 4 and 5	In pin chamber 6 only
6	Master Wafer	See Page 4 and 5	
7	Control Pin	See Page 4 and 5	
8	Driver Pin	See Page 4 and 5	
9	Compression Spring, LFIC	DG-0097	Control Sleeve Pin Chambers Only
10	Compression Spring	DG-0017	All Other Pin Chambers
11	Slider C6M6	DG-0087	For keys with a #6 slider cut
12	Slider Spring	DG-0060	
13	Sidebar Spring	DG-0059	
14	Sidebar	DG-2818	
15	Plug Retainer	DG-0090	
16	Spring Cover	DG-0040	

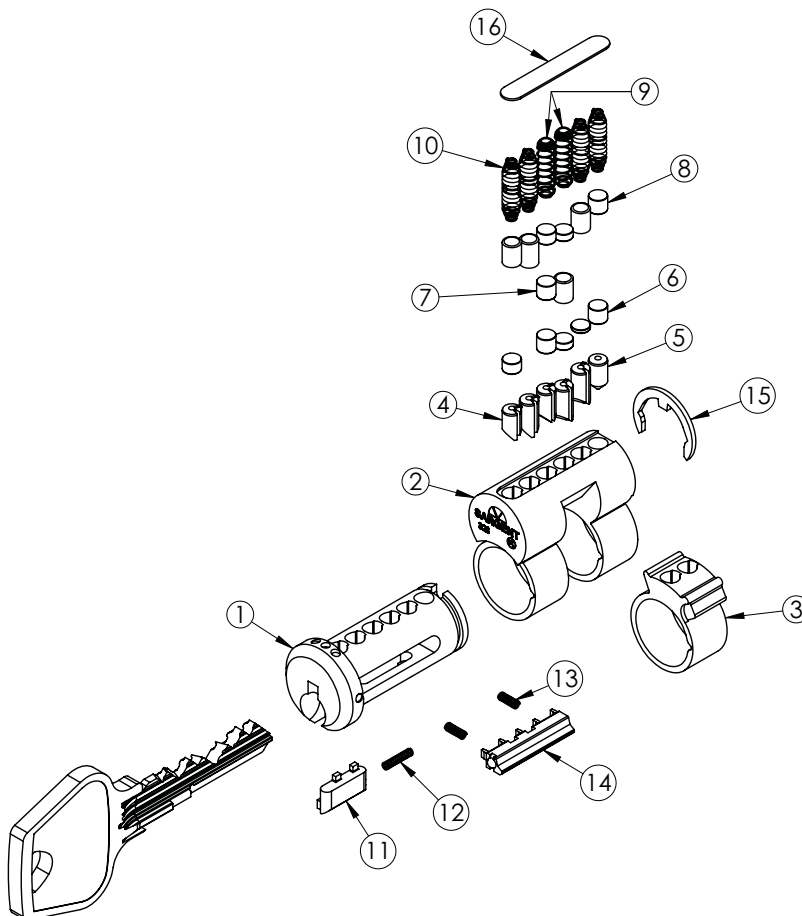

Cylinder Parts: DG1 Bored, Auxiliary & Integrallock

Degree® Key System Technical Manual

SARGENT®
ASSA ABLOY

DG1 Bored, Auxiliary, & Integrallock Cylinder Parts

Item	Description	Part Number	Where Used / Cylinder Length	Comment
1	Plug with tailpiece retainer (item 7)	DG-3061	6, 7, 8L, 10, 11, 6500, 7500 Line Cylinders (Lever Locks)	Plug finishes: 04, 15
		DG-3091	8X Line Cylinders (Knob Locks)	
	Plug with roll pin	DG-3071	7, 8, 9 Line Cylinders (Knob Locks)	
		DG-3029	460, 470, 480, 7500DB Series Deadbolt Cylinders	
	Plug	DG-3043	7600 Integrallock Cylinder	
2	Cylinder Shell	DG-0171	6, 7, 8L, 10, 11, 6500, 7500 Line Cylinders (Lever Locks) 8X Line Cylinders (Knob Locks)	No finish
		DG-0261	7, 8, 9 Line Cylinders (Knob Locks)	
		DG-0161	460, 470, 480, 7500DB Series Deadbolt Cylinders	
		DG-0271	7600 Integrallock Cylinder	
3	Conical Bottom Pin	See Page 4 and 5	All Cylinders	
4	Master Wafer	See Page 4 and 5	All Cylinders	
5	Driver Pin	See Page 4 and 5	All Cylinders	
6	Compression Spring	DG-0017	All Cylinders	
7	Tailpiece Retainer	13-0680	6, 7, 8L, 10, 11, 6500, 7500 Line Cylinders (Lever Locks) 8X Line Cylinders (Knob Locks)	
8	Tailpiece	13-0895	7, 8L, 10, 6500, 7500 Line Cylinders (Lever Locks)	
		13-1385	11 Line Cylinders	
		13-0907	6 Line (S & N knobs) Cylinders	
		13-0908	6 Line (B knob) Cylinders	
		AC-0007	8X Line Cylinders (Knob Locks)	
9	Plug Retainer	DG-0090	6, 7, 8L, 10, 11, 6500, 7500 Line Cylinders (Lever Locks) 7, 8, 8X, 9 Line Cylinders (Knob Locks) 7600 Integrallock Cylinder	
10	Plug Retainer (Deadbolt)	DG-0150	460, 470, 480, 7500DB Series Deadbolt Cylinders	
11	Retainer Screw	DG-0151	460, 470, 480, 7500DB Series Deadbolt Cylinders	# 2-56 x 1/4" (6mm) PH. PAN
12	Tailpiece	DG-2875	Single-Cylinder Deadbolts	
		DG-2876	Double-Cylinder Deadbolts	
13	Spring Cover	13-1341	6, 7, 8L, 10, 11, 6500, 7500 Line Cylinders (Lever Locks) 460, 470, 480, 7500DB Series Deadbolt Cylinders	
		DG-0039	7, 8, 9 Line Cylinders (Knob Locks) 7600 Integrallock Cylinder	

Copyright © 2013-2019, Sargent Manufacturing Company, an ASSA ABLOY Group company. All rights reserved. Reproduction in whole or in part without the express written permission of Sargent Manufacturing Company is prohibited.

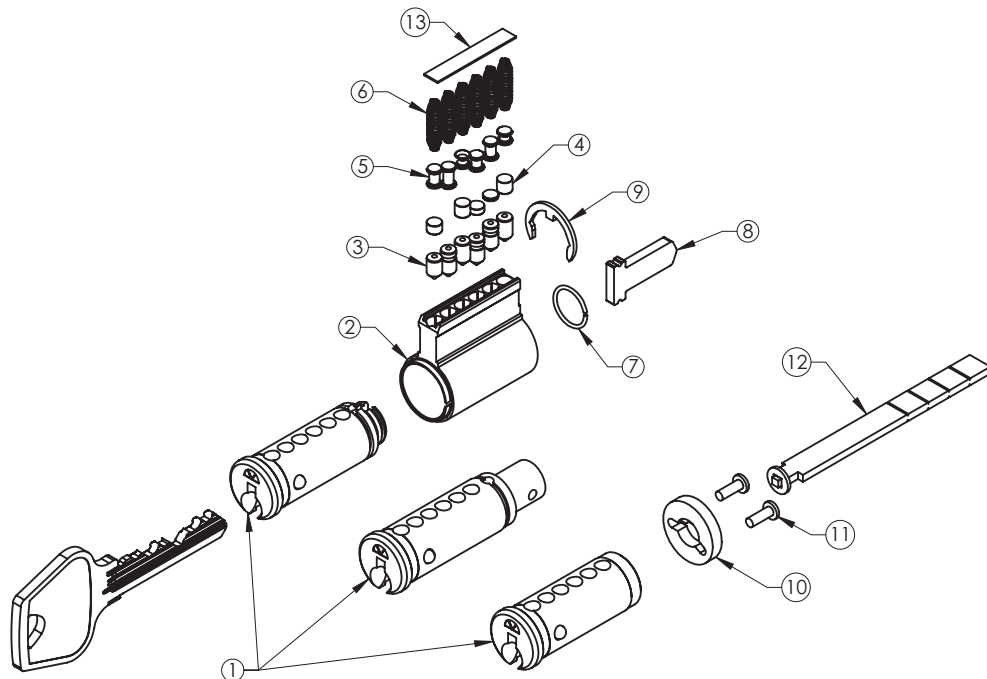

Cylinder Parts: 50-DG1 Bored - Hotel Function

Degree® Key System Technical Manual

SARGENT®

ASSA ABLOY

50-DG1 Bored Cylinder Parts

Item	Description	Part Number	Where Used	Comment
1	Plug	DG-0179	50- 10 Line Cylinders	Plug finishes: 04, 15
		DG-0279	50- 8 Line & 50- 11 Line Cylinders	
2	Cylinder Shell	DG-0171	50- 10 Line Cylinders	No Finish
		DG-0261	50- 8 Line Cylinders	
		DG-0295	50- 11 Line Cylinders	
3	Conical Bottom Pin	See Page 4 and 5	All Cylinders	
4	Master Wafer	See Page 4 and 7	All Cylinders	
5	Bump-Resistant Driver Pin	See Page 4 and 8	All Cylinders	
6	Compression Spring	DG-0017	All Cylinders	
7	Plug Retainer	DG-0090	All Cylinders	
8	Tailpiece Retainer	13-0680	50- 10 Line Cylinders	
9	Tailpiece	13-0845	50- 10 Line Cylinders	
10	Indicator Button	13-0675	50- 10 Line Cylinders	
11	Indicator Button Spring	01-0502	50- 10 Line Cylinders	
12	Indicator Button Pin	01-0503	50- 10 Line Cylinders	
13	Visual Indicator	08-0183	50- 8 Line & 50- 11 Line Cylinders	Shipped with 50- Function Lockset
14	Visual Indicator Spring	08-0213	50- 8 Line & 50- 11 Line Cylinders	
15	Key Block-Out	08-0169	50- 8 Line & 50- 11 Line Cylinders	
16	Spring Cover	DG-0039	All Cylinders	

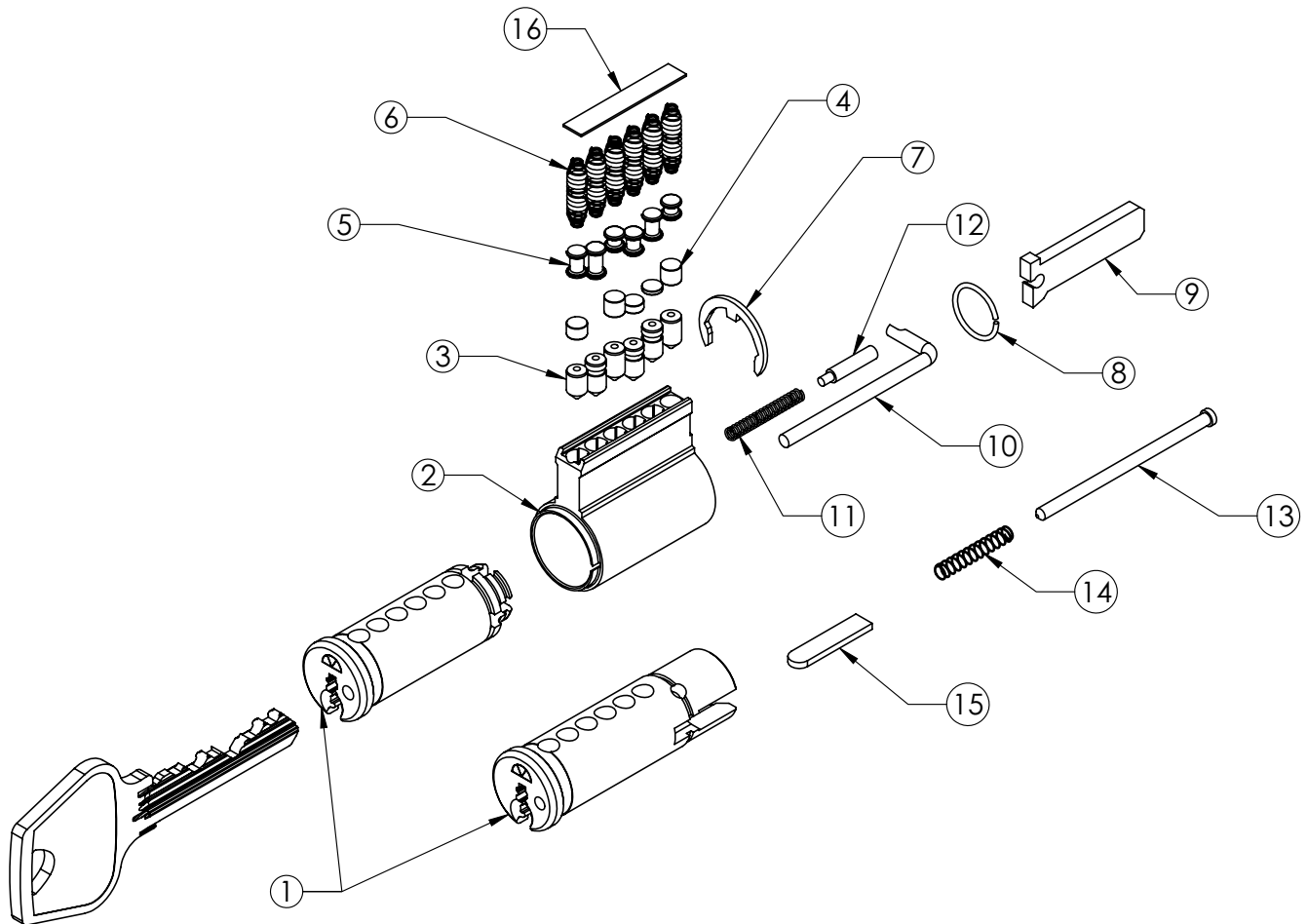

Copyright © 2013-2019, Sargent Manufacturing Company, an ASSA ABLOY Group company. All rights reserved. Reproduction in whole or in part without the express written permission of Sargent Manufacturing Company is prohibited.

Cylinder Parts: DG2 Bored, Auxiliary & Integrallock

Degree® Key System Technical Manual

SARGENT®

ASSA ABLOY

DG2 Bored, Auxiliary, & Integrallock Cylinder Parts

Item	Description	Part Number	Where Used / Cylinder Length	Comment
1	Plug with tailpiece retainer (item 12)	DG-3062	6, 7, 8L, 10, 11, 6500, 7500 Line Cylinders (Lever Locks)	Plug finishes: 04, 15
		DG-3092	8X Line Cylinders (Knob Locks)	
	Plug with roll pin	DG-3072	7, 8, 9 Line Cylinders (Knob Locks)	
		DG-0166	460, 470, 480, 7500DB Series Deadbolt Cylinders	
	Plug	DG-0276	7600 Integrallock Cylinder	
2	Cylinder Shell	DG-0172	6, 7, 8L, 10, 11, 6500, 7500 Line Cylinders (Lever Locks) 8X Line Cylinders (Knob Locks)	No finish
		DG-0262	7, 8, 9 Line Cylinders (Knob Locks)	
		DG-0162	460, 470, 480, 7500DB Series Deadbolt Cylinders	
		DG-0272	7600 Integrallock Cylinder	
3	Chisel Tipped Bottom Pin	See Page 4 and 5	All Cylinders	In pin chambers 1 through 5
4	Conical Bottom Pin	See Page 4 and 5	All Cylinders	In pin chamber 6 only
5	Master Wafer	See Page 4 and 5	All Cylinders	
6	Driver Pin	See Page 4 and 5	All Cylinders	
7	Compression Spring	DG-0017	All Cylinders	
8	Slider C6M6	DG-0087	All Cylinders	For keys with a #6 slider cut
9	Slider Spring	DG-0060	All Cylinders	
10	Sidebar Spring	DG-0059	All Cylinders	
11	Sidebar	DG -2818	All Cylinders	
12	Tailpiece Retainer	13-0680	6, 7, 8L, 10, 11, 6500, 7500 Line Cylinders (Lever Locks) 8X Line Cylinders (Knob Locks)	
13	Tailpiece	13-0895	7, 8L, 10, 6500, 7500 Line Cylinders (Lever Locks)	
		13-1385	11 Line Cylinders	
		13-0907	6 Line (S & N knobs) Cylinders	
		13-0908	6 Line (B knob) Cylinders	
		AC-0007	8X Line Cylinders (Knob Locks)	
14	Plug Retainer	DG-0090	6, 7, 8L, 10, 11, 6500, 7500 Line Cylinders (Lever Locks) 7, 8, 8X, 9 Line Cylinders (Knob Locks) 7600 Integrallock Cylinder	
15	Plug Retainer (Deadbolt)	DG-0150	460, 470, 480, 7500DB Series Deadbolt Cylinders	
16	Retainer Screw	DG-0151	460, 470, 480, 7500DB Series Deadbolt Cylinders	# 2-56 x 1/4" (6mm) PH. PAN
17	Tailpiece	DG-2875	Single-Cylinder Deadbolts	
		DG-2876	Double-Cylinder Deadbolts	
18	Spring Cover	13-1341	6, 7, 8L, 10, 11, 6500, 7500 Line Cylinders (Lever Locks) 460, 470, 480, 7500DB Series Deadbolt Cylinders	
		DG-0039	7, 8, 9 Line Cylinders (Knob Locks) 7600 Integrallock Cylinder	

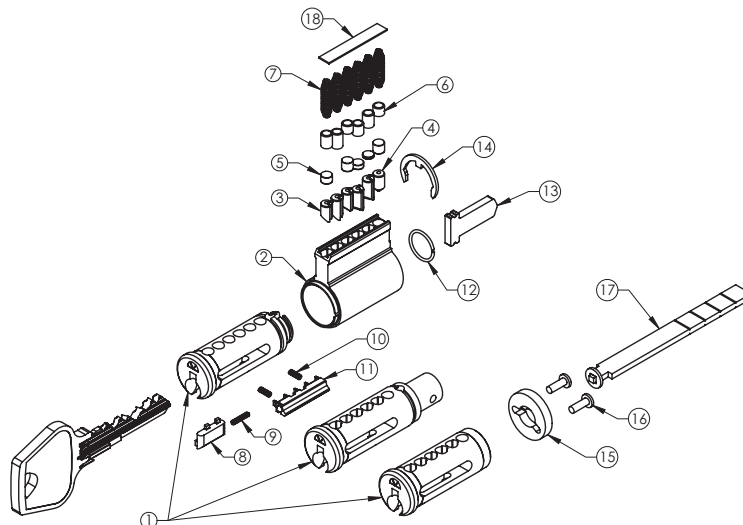

Copyright © 2013-2019, Sargent Manufacturing Company, an ASSA ABLOY Group company. All rights reserved. Reproduction in whole or in part without the express written permission of Sargent Manufacturing Company is prohibited.

90726 06/19

Cylinder Parts: DG3 Bored, Auxiliary & Integrallock

Degree® Key System Technical Manual

SARGENT®

ASSA ABLOY

DG3 Bored, Auxiliary, & Integrallock Cylinder Parts

Item	Description	Part Number	Where Used / Cylinder Length	Comment
1	Plug with tailpiece retainer (item 12)	DG-3063	6, 7, 8L, 10, 11, 6500, 7500 Line Cylinders (Lever Locks)	Plug finishes: 04, 15
		DG-3093	8X Line Cylinders (Knob Locks)	
	Plug with roll pin	DG-3073	7, 8, 9 Line Cylinders (Knob Locks)	
	Plug	DG-3030	460, 470, 480, 7500DB Series Deadbolt Cylinders	
	Plug	DG-3044	7600 Integrallock Cylinder	
2	Cylinder Shell	DG-0172	6, 7, 8L, 10, 11, 6500, 7500 Line Cylinders (Lever Locks) 8X Line Cylinders (Knob Lock)	No finish
		DG-0262	7, 8, 9 Line Cylinders (Knob Locks)	
		DG-0162	460, 470, 480, 7500DB Series Deadbolt Cylinders	
		DG-0272	7600 Integrallock Cylinder	
3	Chisel Tipped Bottom Pin	See Page 4 and 5	All Cylinders	In pin chambers 1 through 5
4	Conical Bottom Pin	See Page 4 and 5	All Cylinders	In pin chamber 6 only
5	Master Wafer	See Page 4 and 5	All Cylinders	
6	Driver Pin	See Page 4 and 5	All Cylinders	
7	Compression Spring	DG-0017	All Cylinders	
8	Slider C6M6	DG-0087	All Cylinders	For keys with a #6 slider cut
9	Slider Spring	DG-0060	All Cylinders	
10	Sidebar Spring	DG-0059	All Cylinders	
11	Sidebar	DG -2818	All Cylinders	
12	Tailpiece Retainer	13-0680	6, 7, 8L, 10, 11, 6500, 7500 Line Cylinders (Lever Locks) 8X Line Cylinders (Knob Locks)	
13	Tailpiece	13-0895	7, 8L, 10, 6500, 7500 Line Cylinders (Lever Locks)	
		13-1385	11 Line Cylinders	
		13-0907	6 Line (S & N knobs) Cylinders	
		13-0908	6 Line (B knob) Cylinders	
		AC-0007	8X Line Cylinders (Knob Locks)	
14	Plug Retainer	DG-0090	6, 7, 8L, 10, 11, 6500, 7500 Line Cylinders (Lever Locks) 7, 8, 8X, 9 Line Cylinders (Knob Locks) 7600 Integrallock Cylinder	
15	Plug Retainer (Deadbolt)	DG-0150	460, 470, 480, 7500DB Series Deadbolt Cylinders	
16	Retainer Screw	DG-0151	460, 470, 480, 7500DB Series Deadbolt Cylinders	# 2-56 x 1/4" (6mm) PH. PAN
17	Tailpiece	DG-2875	Single-Cylinder Deadbolts	
		DG-2876	Double-Cylinder Deadbolts	
18	Spring Cover	13-1341	6, 7, 8L, 10, 11, 6500, 7500 Line Cylinders (Lever Locks) 460, 470, 480, 7500DB Series Deadbolt Cylinders	
		DG-0039	7, 8, 9 Line Cylinders (Knob Locks) 7600 Integrallock Cylinder	

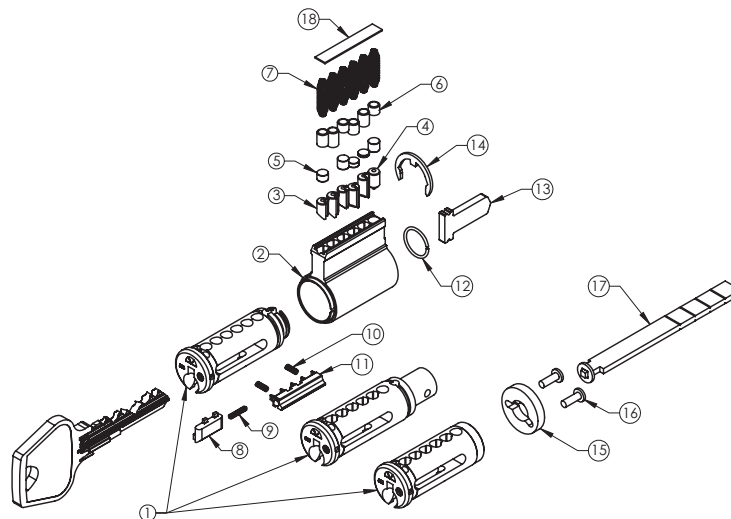

SARGENT Manufacturing Company
100 Sargent Drive
New Haven, CT 06511 USA
800-727-5477
www.sargentlock.com

ASSA ABLOY is the global
leader in door opening solutions,
dedicated to satisfying
end-user needs for security,
safety and convenience