

INSTALLATION INSTRUCTIONS FOR "10 FUNCTION" LEVER TRIM (10 and 30 series)

Drawing: 107123

Table of Contents	Page
Device parts breakdown view.....	2
Device parts breakdown list with part numbers.....	3
Trim Prep.....	4
Door Prep Rim.....	5
Door Prep Mortise.....	6
Trim Installation.....	7

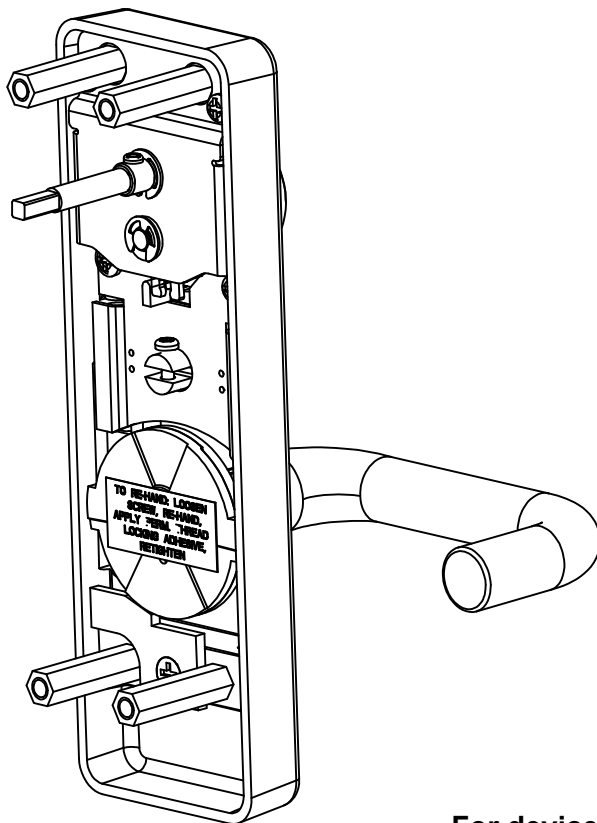

For WARRANTY information,
scan code below or
go to www.detex.com/warranty



For device installation videos,
scan code below or
go to www.detex.com/videos



Owner's Copy

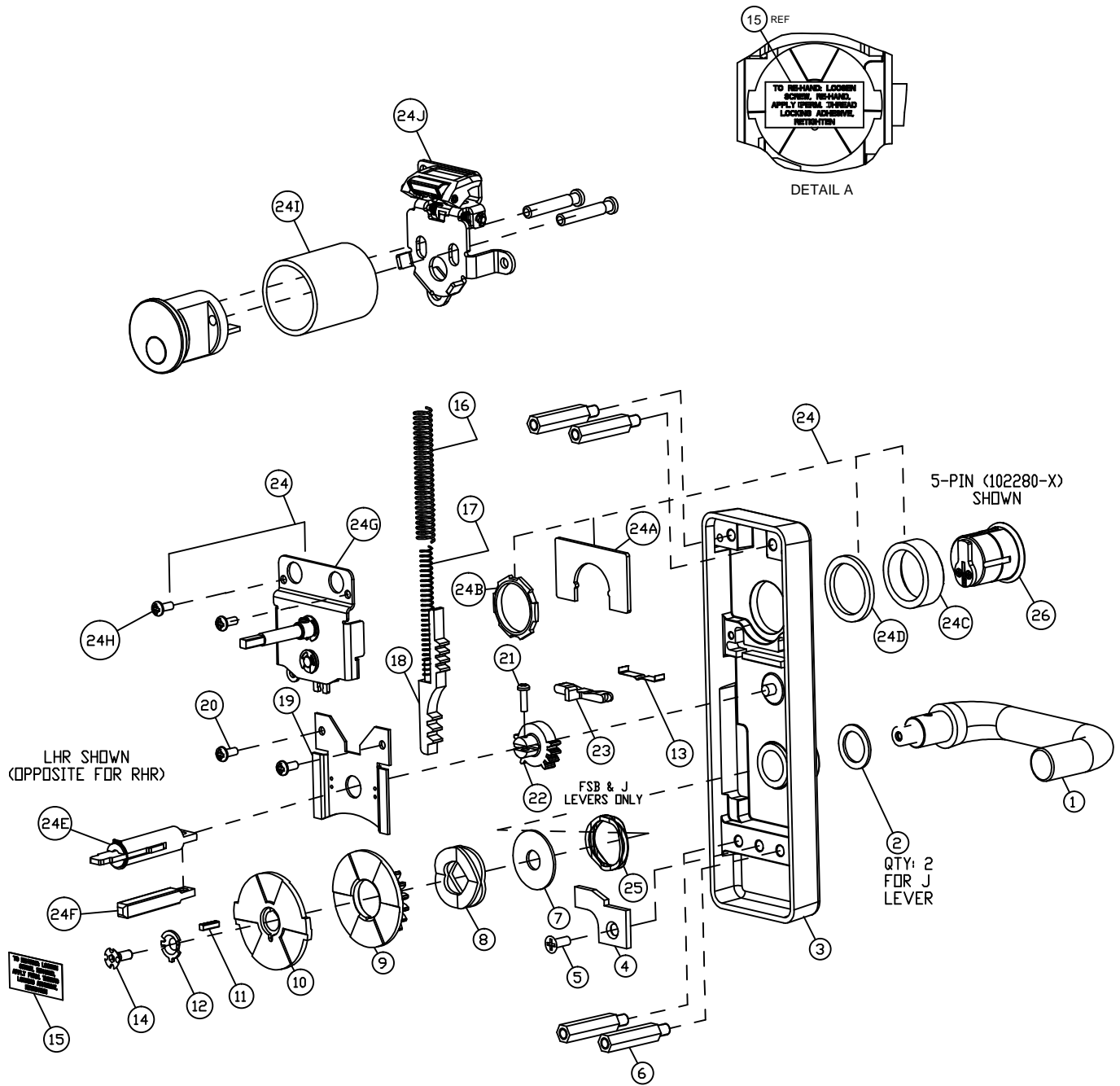

PARTS BREAKDOWN			
Item	Order Part #	QTY	Description
1	106494-8	1	LEVER ASSY, J, LHR, 629
	106494-9		LEVER ASSY, J, LHR, 630
	106495-8		LEVER ASSY, J, RHR, 629
	106495-9		LEVER ASSY, J, RHR, 630
	105965-1016		LEVER ASSY, FSB, 1016, 630
	105965-1035		LEVER ASSY, FSB, 1035, 630
	105965-1058		LEVER ASSY, FSB, 1058, 630
	105965-1075		LEVER ASSY, FSB, 1075, 630
	105965-1076		LEVER ASSY, FSB, 1076, 630
	105965-1093		LEVER ASSY, FSB, 1093, 630
	105965-1108		LEVER ASSY, FSB, 1108, 630
	105965-1119-1		LEVER ASSY, FSB, 1119, RHR, 630
	105965-1119-2		LEVER ASSY, FSB, 1119, LHR, 630
	105965-1147		LEVER ASSY, FSB, 1147, 630
	106264-7		LEVER ASSY, Q, 626
	106264-14		LEVER ASSY, Q, 693
	106264-15		LEVER ASSY, Q, 695
	101376-7		LEVER ASSY, S, 626
	101376-14		LEVER ASSY, S, 693
	101376-15		LEVER ASSY, S, 695
	101375-7		LEVER ASSY, U, 626
	101375-14		LEVER ASSY, U, 693
	101375-15		LEVER ASSY, U, 695
	101374-7		LEVER ASSY, T, 626
	101374-14		LEVER ASSY, T, 693
	101374-15		LEVER ASSY, T, 695
	2		106603
100851		1	WASHER, FLAT, 1"x0.06 THK (ALL EXCEPT J LEVER)
3	103344-7	1	EXCUTCHEON ASY 08D BP1 10 FUNC IND, 626
	103344-9		EXCUTCHEON ASY 08D BP1 10 FUNC IND, 630
	103344-14		EXCUTCHEON ASY 08D BP1 10 FUNC IND, 693
	103344-15		EXCUTCHEON ASY 08D BP1 10 FUNC IND, 695
4	100771	1	STOP, ROTATIONAL
5	PP-5305-108	1	SCREW, MACH, 10-24 X 1/2 PFH
6	100777	4	STANDOFF, HEX
7	100775	1	WASHER, FLAT
8	103047	1	CLUTCH SPRING
9	103043	1	BOTTOM GEAR, WIDE
10	103044	1	TORQUE PLATE, WIDE
11	103994	1	KEY, SHEAR PIN, STEEL
12	100821	1	WASHER CLUTCH
13	100773	1	FLAT SPRING LOCKING
14	102536-1	1	SCREW, 10-24, CUSTOM
15	103029	1	LABEL, REHANDING
16	100766	1	SPRING, RETURN
17	101509	1	SPRING, RETURN, HELPER

Your particular part or configuration
may not be shown:
Contact Detex technical support
at 800-729-3839 (option 2)

PARTS BREAKDOWN CONTINUED			
Item	Order Part #	QTY	Description
18	101436	1	RACK ASSEMBLY
19	100753	1	COVER PLATE
20	PP-5378-106	2	SCREW, MACH, 8-32 x 3/8 PPH
21	PP-5367-108	1	SCREW, MACH, 6-32 x 1/2 PPH
22	100762	1	TOP GEAR
23	101993	1	LOCK SLIDE
24KIT	107112-5	1	HARDWARE KIT 08D TRIM 10 FUNC LHR, 613, RIM
	107112-7		HARDWARE KIT 08D TRIM 10 FUNC LHR, 626, RIM
	107112-12		HARDWARE KIT 08D TRIM 10 FUNC LHR, 613, MORTISE
	107112-14		HARDWARE KIT 08D TRIM 10 FUNC LHR, 626, MORTISE
	107113-5		HARDWARE KIT 08D TRIM 10 FUNC RHR, 613, RIM
	107113-7		HARDWARE KIT 08D TRIM 10 FUNC RHR, 626, RIM
	107113-12		HARDWARE KIT 08D TRIM 10 FUNC RHR, 613, MORTISE
	107113-14		HARDWARE KIT 08D TRIM 10 FUNC RHR, 626, MORTISE
24A	100754	1	PLATE, CYLINDER POSITION
24B	100783	1	NUT, HEXAGON, CYLINDER
24C	103332-7	1	CYLINDER COLLAR, 5-PIN, CHROME 626
24D	103346-7	3	CYLINDER COLLAR, 1/8, CHROME 626
24E	101478	1	SHAFT EXTENSION ASSEMBLY
24F	103218	1	SHAFT, INPUT (MORTISE)
24G	107110-1	1	TRIM GEAR ASY 10-FUNCTION
24H	PP-5378-106	2	SCREW, MACH, 8-32 x 3/8 PPH
24I	NO SALE	1	COLLAR, CYLINDER
24J	107114-1	1	CYL BRKT ASY, 10-FUNCTION IND LHR
	107115-1		CYL BRKT ASY, 10-FUNCTION IND RHR
25	NO SALE	1	WASHER, WAVE
26	103800-612	1	CYLINDER HOUSING, MORTISE, 7 PIN, BRONZE
	103800-613		CYLINDER HOUSING, MORTISE, 7 PIN, OIL RUB BRONZE
	103800-626		CYLINDER HOUSING, MORTISE, 7 PIN, CHROME
	102281-4-X		CYLINDER, MORTISE, 5 PIN, BRONZE
	102281-5-X		CYLINDER, MORTISE, 5 PIN, OIL RUB BRONZE
	102281-7-X		CYLINDER, MORTISE, 5 PIN, CHROME

FOR ITEM 26
"-X" REFERS TO
KEY CODE
AA THRU KK



Your particular part or configuration
may not be shown:
Contact Detex technical support
at 800-729-3839 (option 2)

STEP 1: PREP TRIM

NOTE:

1. Mortise cylinder NOT supplied with trim, but can be ordered separately.
2. Trim handing is field reversible. Device cover is handed and must be ordered RHR or LHR (see step 4).
3. 6-pin cylinder installation shown.

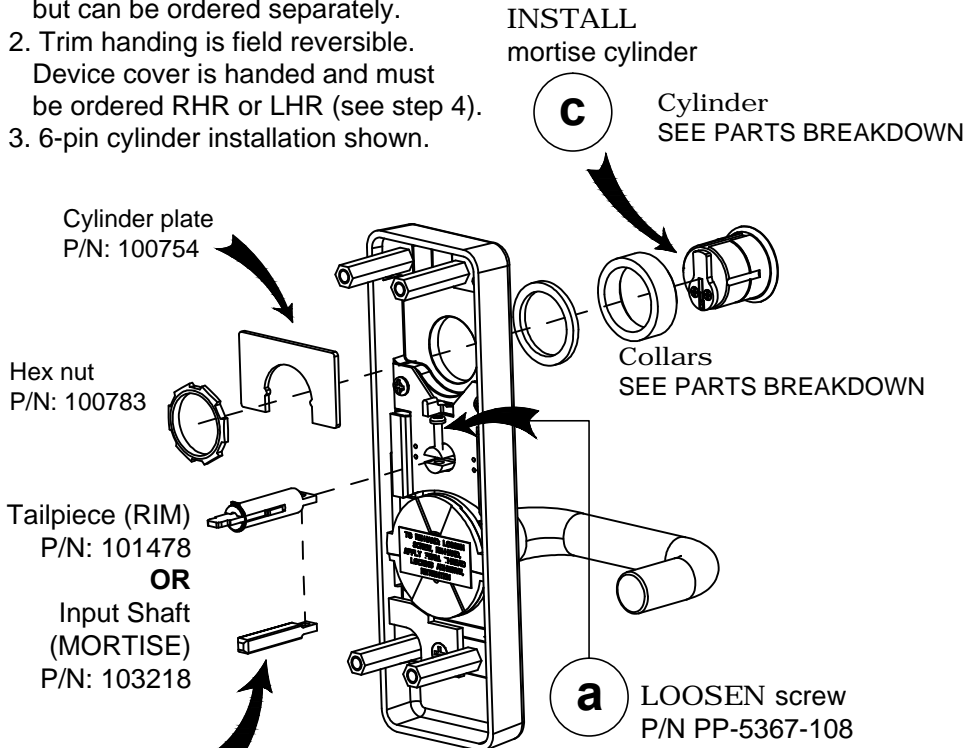





Collar & Spacer Combinations	
	5 pin cylinder (use collar only)
	6 pin cylinder (use collar & 1 spacer)
	7 pin cylinder (use collar & 2 spacers)
	7 pin IC cylinder (use collar & 3 spacers)
Collar & Spacer	

STEP 2: PREP DOOR (Rim)

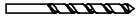
Mark and drill holes

(LHR installation shown, reverse all steps for RHR)

(Metal Doors Only)			
Hole "A"	Hole "B"	Hole "C"	Hole "D"
DRILL 5/16 hole through Device Side	DRILL 1/2 hole through Trim Side	DRILL 3/4 hole through Trim & Device Side	DRILL 1/4 hole through Device Side
			
5/16"	1/2"	3/4"	1/4"

MARK HOLES

DRILL HOLES

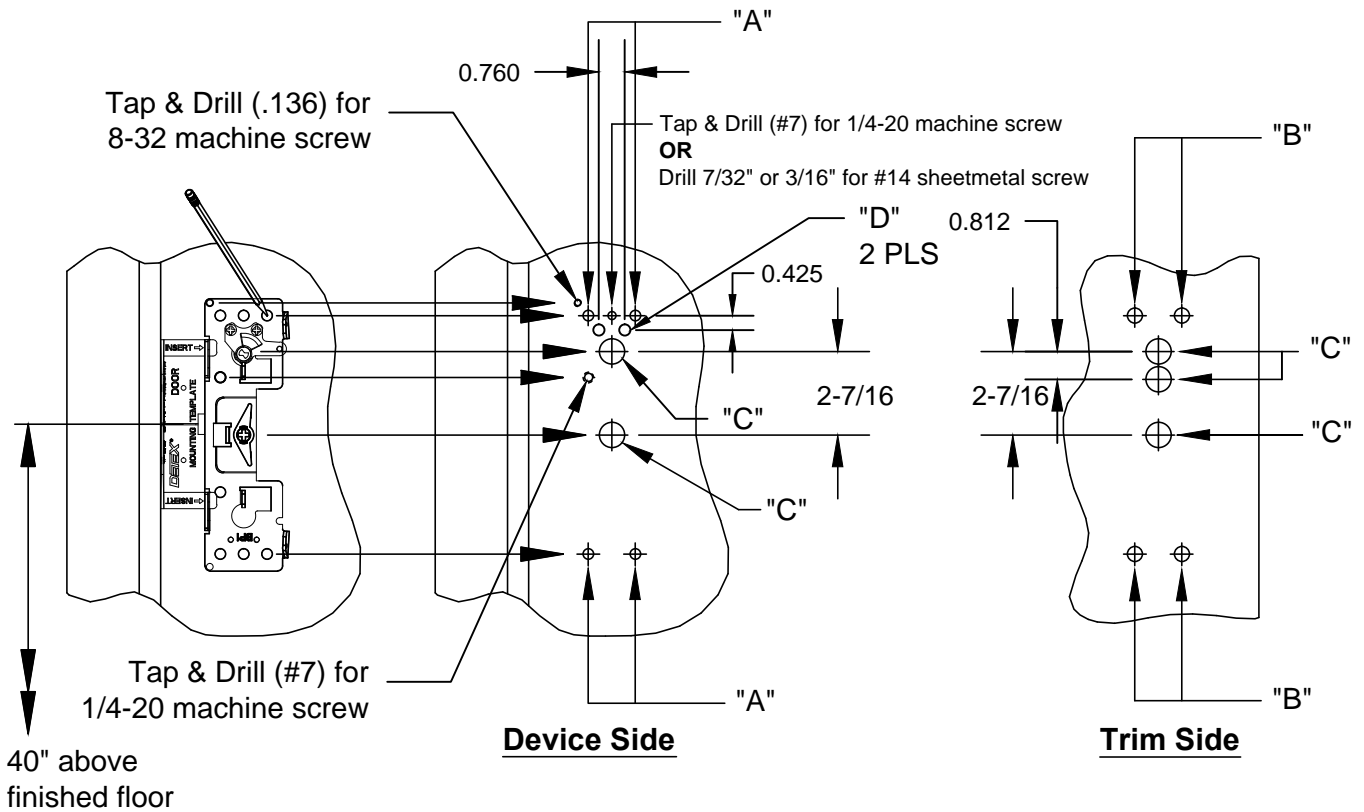

STEP 2: PREP DOOR (Mortise)

TRIM SIDE: Use plastic template to mark and drill TRIM holes

(LHR installation shown, reverse all steps for RHR)

MARK HOLES

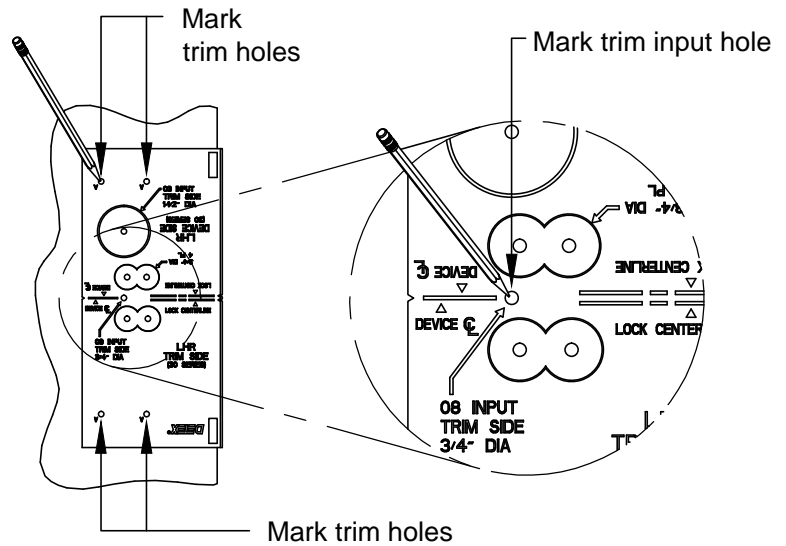
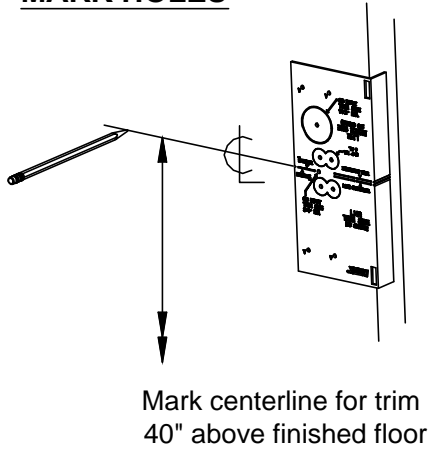

DRILL HOLES ON TRIM SIDE

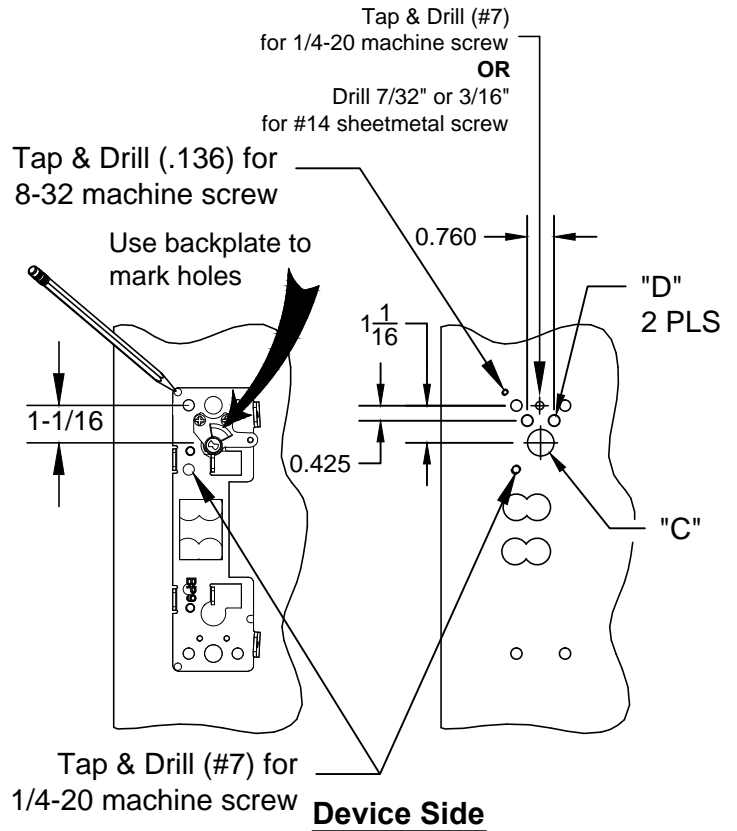
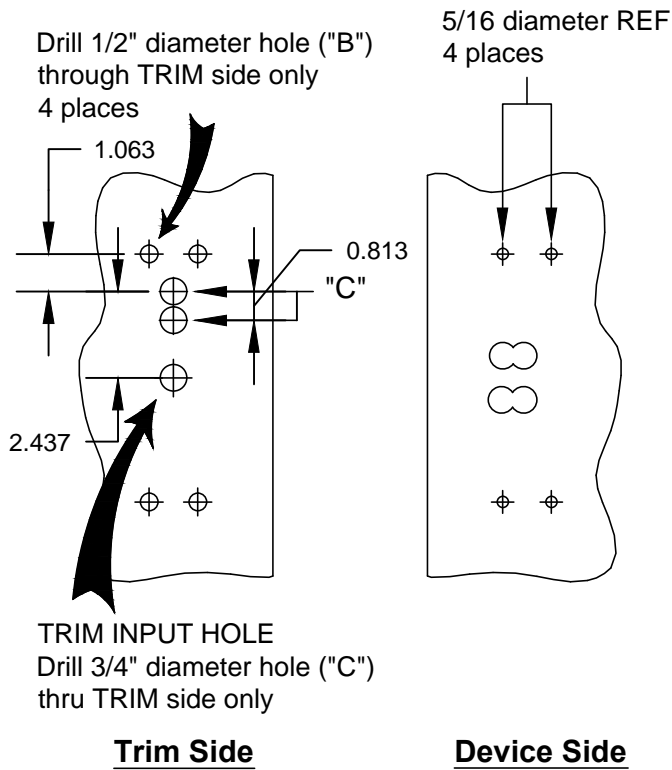

NOTE:

1) For a retrofit application, remove mortise lock (if required) and device before installing new trim.

STEP 3: INSTALL TRIM (RIM installation shown)

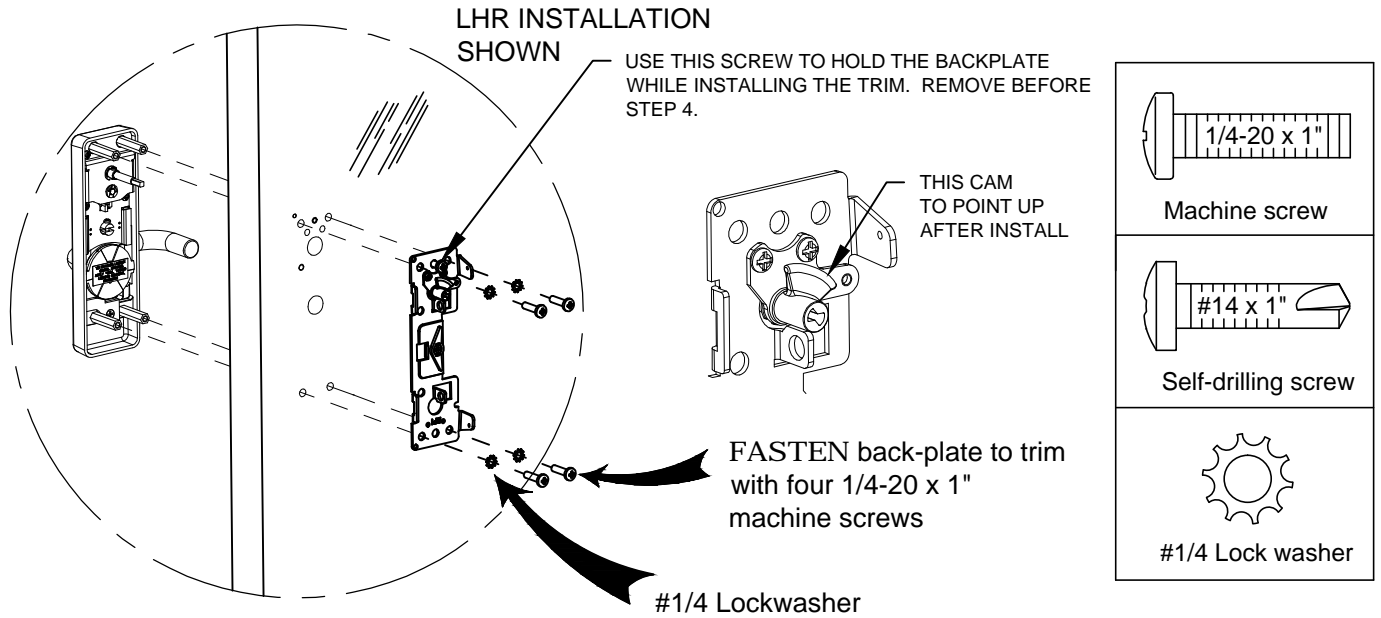

STEP 4: INSTALL DEVICE AND BRACKET ASSEMBLY (RIM installation shown)

