

METAL DOOR

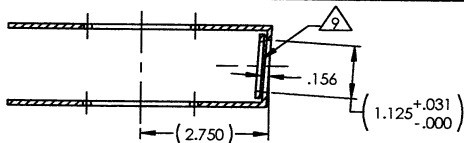

SECTION A-A

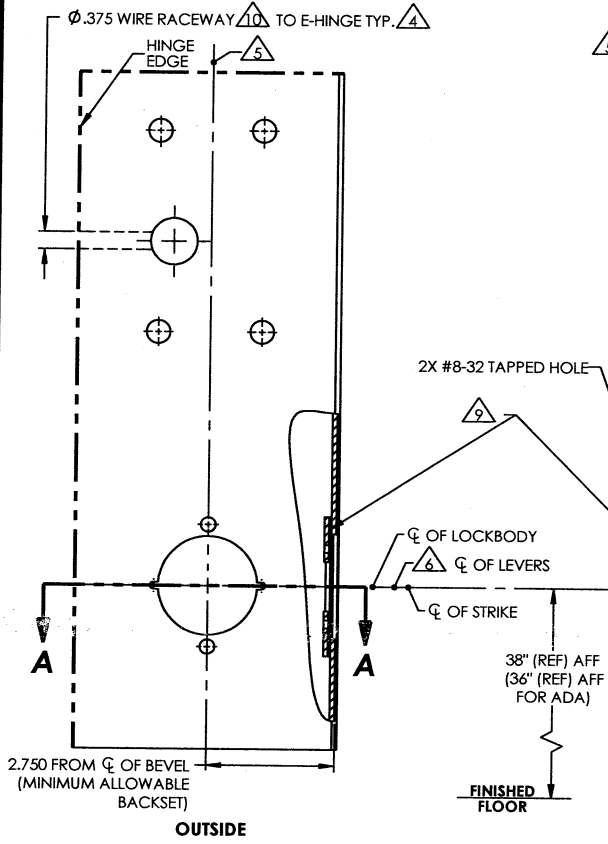

OUTSIDE

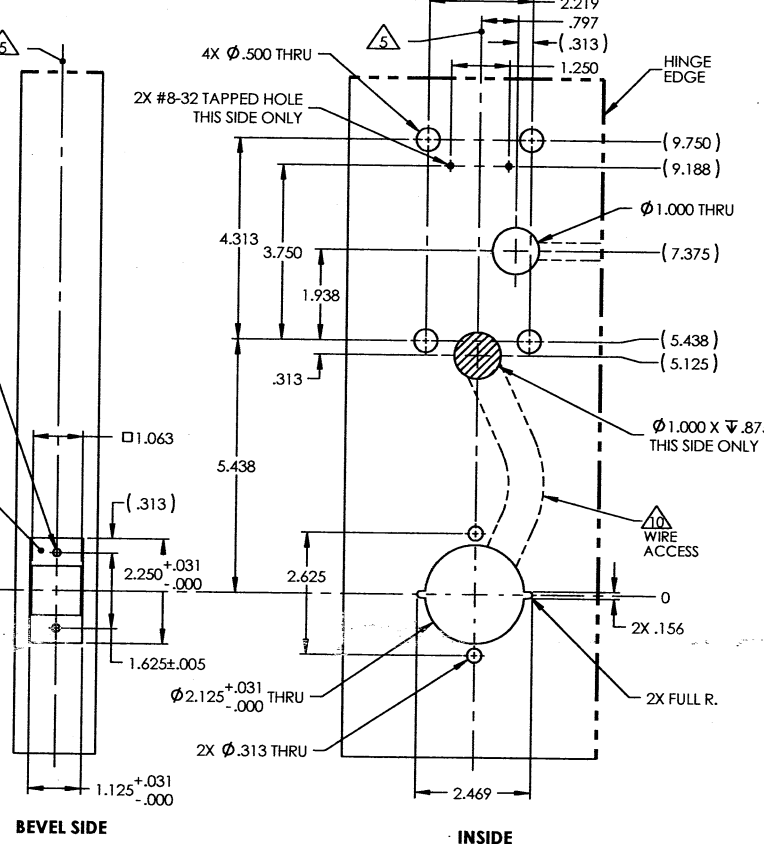

BEVEL SIDE

INSIDE

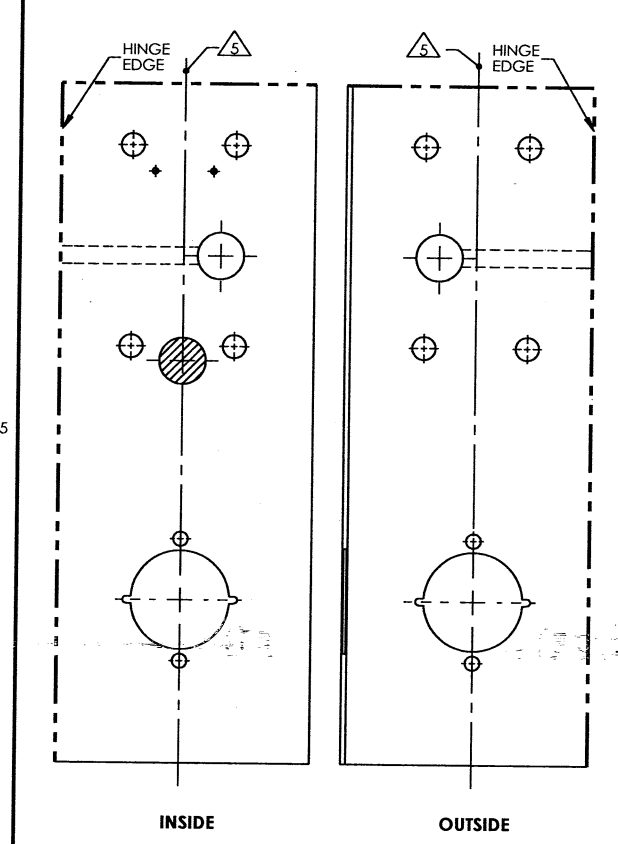

INSIDE

OUTSIDE

- NOTES:
- DRAWING IS NOT TO SCALE.
 - PREPARATION DETAILS ARE IN SUPPLEMENT TO ANSI/BHMA A156.115 AND/OR A115W.
 - REFERENCE STRIKE TEMPLATE FOR DETAILS TO PREPARE FRAME.
 - FOR ELECTROLYNX APPLICATIONS, REFER TO MCKINNEY TRANSFER DEVICE CATALOG.
 - VERTICAL CENTERLINE IS REFERENCED FROM THE CENTERLINE OF THE BEVEL. (INDUSTRY STANDARD BEVEL IS 1/8 INCH IN 2 INCHES.)
 - CONSULT THE AUTHORITY HAVING JURISDICTION (AHJ) TO VERIFY THE RECOMMENDED MOUNTING HEIGHT ABOVE THE FINISHED FLOOR (AFF). LIMITATIONS IN THE DOOR CONSTRUCTION PROCESS MAY REQUIRE SOME HOLES TO BE FIELD-LOCATED USING THE PHYSICAL PART AS A TEMPLATE.
 - STANDARD TOLERANCE OF ± .015 APPLIES TO ALL DOOR PREPARATION REQUIREMENTS, UNLESS OTHERWISE SPECIFIED.
 - DOOR REINFORCEMENT IS RECOMMENDED TO IMPROVE (SURFACE MOUNTED) FASTENER HOLDING POWER AND CRUSH RESISTANCE (WHEN THRU-BOLTING IS EMPLOYED). CONSTRUCTION TECHNIQUES SHOULD REFLECT INDUSTRY BEST PRACTICES (I.E. WDMA, SDI) AND AUTHORIZED METHODS WHERE LABEL SERVICE (I.E. UL, W-H) IS IN EFFECT.
 - WIRE RACEWAY AREAS SHALL BE FREE OF OBSTRUCTIONS & SHARP EDGES TO PROTECT WIRES FROM CUTS & ABRASIONS.
 - CAREFULLY NOTE WHICH FEATURES ARE OPTIONAL, (WHETHER THE FEATURE APPLIES TO BOTH SIDES OF THE DOOR AND/OR IF A DEPTH APPLIES.)
 - MAXIMUM PRODUCT DIMENSIONS ARE SHOWN FOR THE PURPOSE OF VERIFYING FITMENT WITH DOOR FRAME STOPS, DOOR STILE SIZE & LIGHT/LOUVER KITS.
 - IF OPTIONAL LEVERS OR ROSES ARE USED REFERENCE THE RELATED PRODUCT DIMENSIONS TO VERIFY THE FITMENT REQUIREMENTS.

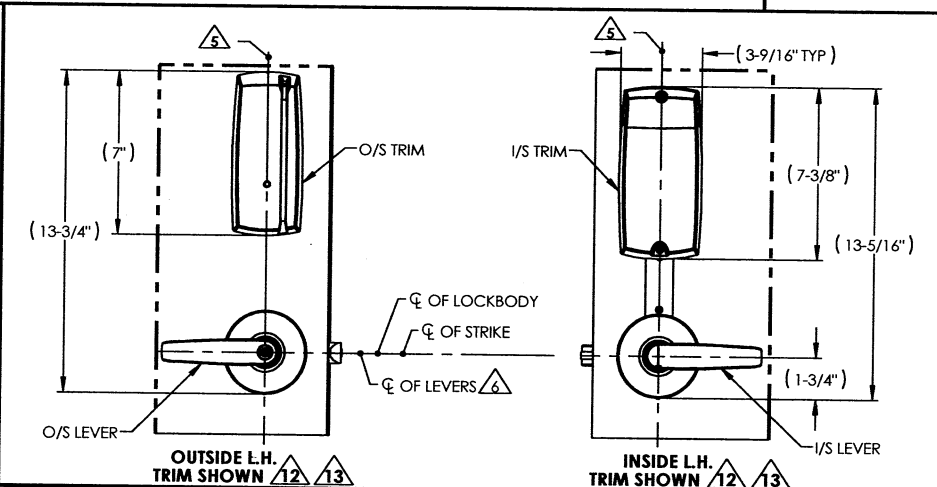

OUTSIDE L.H. TRIM SHOWN 12 13

INSIDE L.H. TRIM SHOWN 12 13

AUTHORIZED PREFIXES	
P1	
BACKSET DEFINITION	DOOR HANDING
<p>SARGENT Sargent Manufacturing Company 100 Sargent Drive New Haven, CT 06511</p>	
<p>ASSA ABLOY DOOR MANUFACTURERS TEMPLATE: P1 PASSPORT 1000 TRIM "W/O DPS" METAL DOOR 10 LINE BORED LOCK</p>	<p>RELEASE DATE 03-NOV-10 TEMPLATE NO. 4658 B</p>
SHEET 1 OF 2	

WOOD DOOR

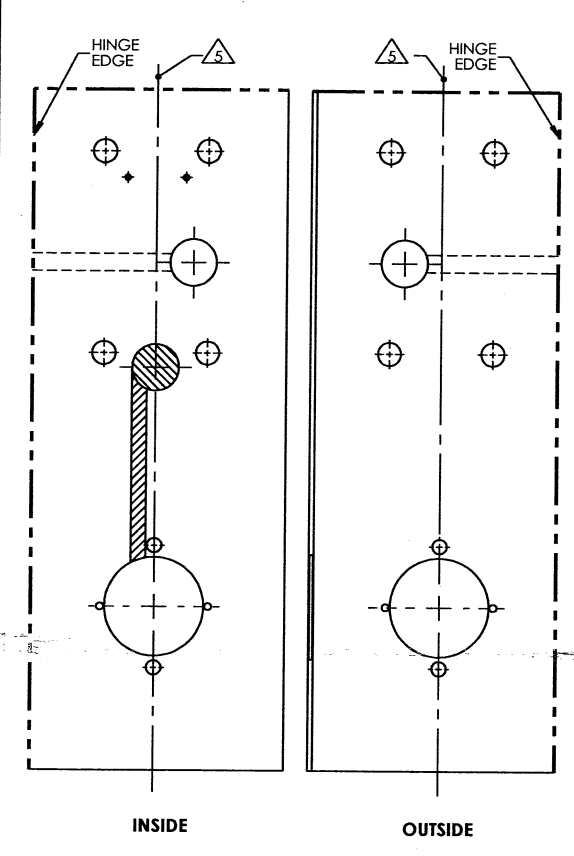
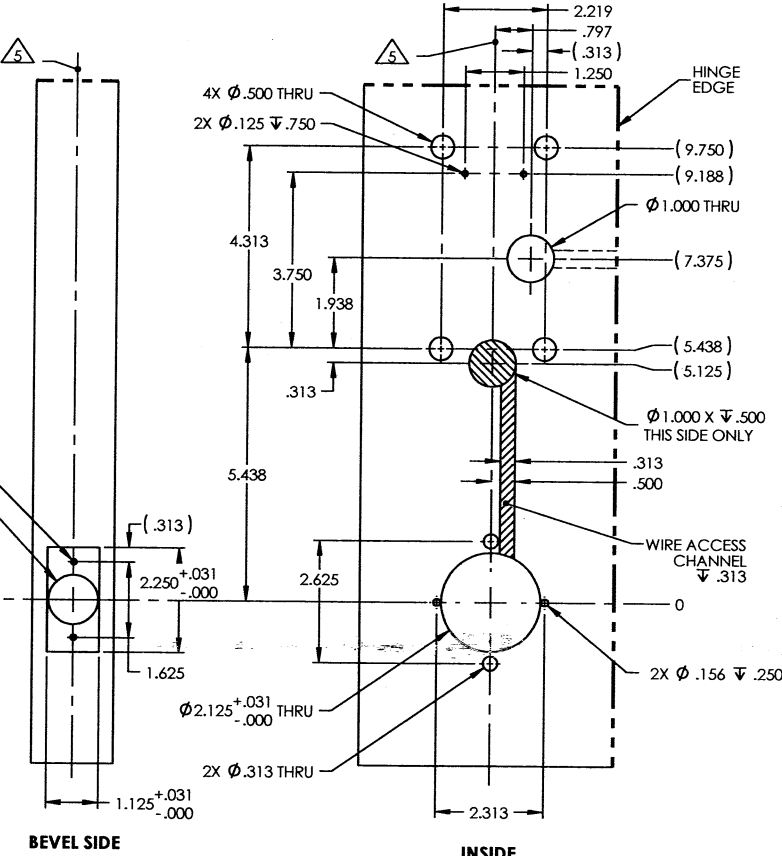
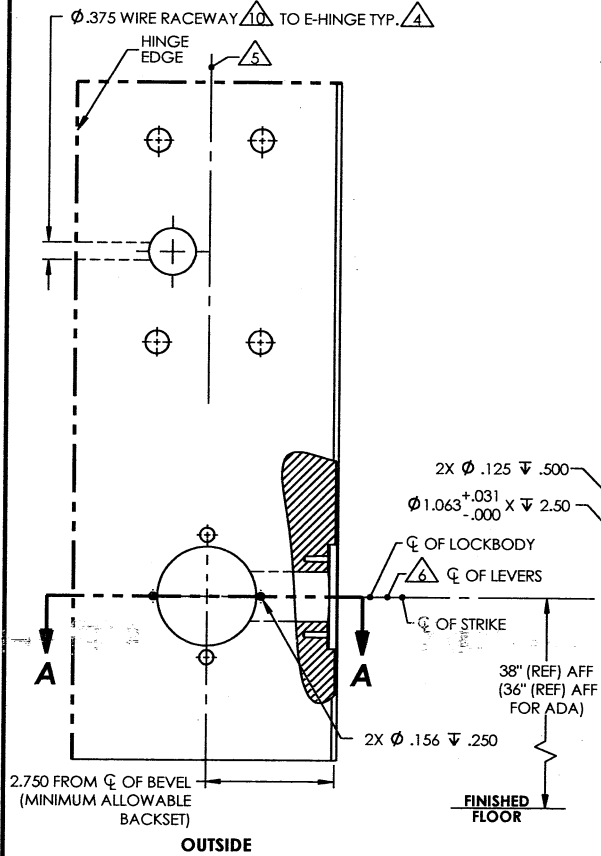
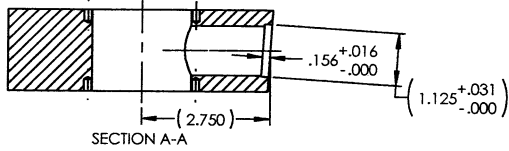

- NOTES:**
- DRAWING IS NOT TO SCALE.
 - PREPARATION DETAILS ARE IN SUPPLEMENT TO ANSI/BHMA A156.115 AND/OR A115W.
 - REFERENCE STRIKE TEMPLATE FOR DETAILS TO PREPARE FRAME.
 - FOR ELECTROLYNX APPLICATIONS, REFER TO MCKINNEY TRANSFER DEVICE CATALOG.
 - VERTICAL CENTERLINE IS REFERENCED FROM THE CENTERLINE OF THE BEVEL (INDUSTRY STANDARD BEVEL IS 1/8 INCH IN 2 INCHES.)
 - CONSULT THE AUTHORITY HAVING JURISDICTION (AHJ) TO VERIFY THE RECOMMENDED MOUNTING HEIGHT ABOVE THE FINISHED FLOOR (AFF). LIMITATIONS IN THE DOOR CONSTRUCTION PROCESS MAY REQUIRE SOME HOLES TO BE FIELD-LOCATED USING THE PHYSICAL PART AS A TEMPLATE.
 - STANDARD TOLERANCE OF $\pm .015$ APPLIES TO ALL DOOR PREPARATION REQUIREMENTS, UNLESS OTHERWISE SPECIFIED.
 - DOOR REINFORCEMENT IS RECOMMENDED TO IMPROVE (SURFACE MOUNTED) FASTENER HOLDING POWER AND CRUSH RESISTANCE (WHEN THRU-BOLTING IS EMPLOYED). CONSTRUCTION TECHNIQUES SHOULD REFLECT INDUSTRY BEST PRACTICES (I.E. WDMA, SDI) AND AUTHORIZED METHODS WHERE LABEL SERVICE (I.E. UL, W-H) IS IN EFFECT.
 - WIRE RACEWAY AREAS SHALL BE FREE OF OBSTRUCTIONS & SHARP EDGES TO PROTECT WIRES FROM CUTS & ABRASIONS.
 - CAREFULLY NOTE WHICH FEATURES ARE OPTIONAL, (WHETHER THE FEATURE APPLIES TO BOTH SIDES OF THE DOOR AND/OR IF A DEPTH APPLIES.)
 - MAXIMUM PRODUCT DIMENSIONS ARE SHOWN FOR THE PURPOSE OF VERIFYING FITMENT WITH DOOR FRAME STOPS, DOOR STILE SIZE & LIGHT/LOUVER KITS.
 - IF OPTIONAL LEVERS OR ROSES ARE USED REFERENCE THE RELATED PRODUCT DIMENSIONS TO VERIFY THE FITMENT REQUIREMENTS.

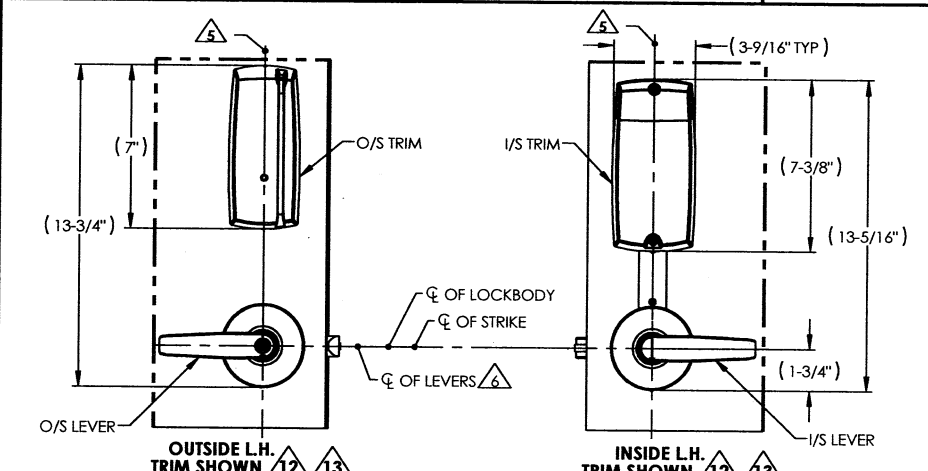

AUTHORIZED PREFIXES	
P1	
BACKSET DEFINITION	DOOR HANDING
SARGENT ASSA ABLDY Sargent Manufacturing Company 100 Sargent Drive New Haven, CT 06511	
DOOR MANUFACTURERS TEMPLATE: P1 PASSPORT 1000 TRIM "W/O DPS" WOOD DOOR 10 LINE BORED LOCK	RELEASE DATE 03-NOV-10 TEMPLATE NO. 4658 B
SHEET 2 OF 2	