



ELECTRIC EXIT DEVICE KIT INSTALLATION INSTRUCTIONS MOTOR DRIVE ELECTRIC LATCH RETRACTION

1550K-MDD DORMA 9000 SERIES

Electrical Input Requirements:

Filtered and Regulated Power Supply
Voltage: 24VDC \pm 10%
Current: 1A MAX Inrush, 400mA MAX Holding
Non-polarized Leads

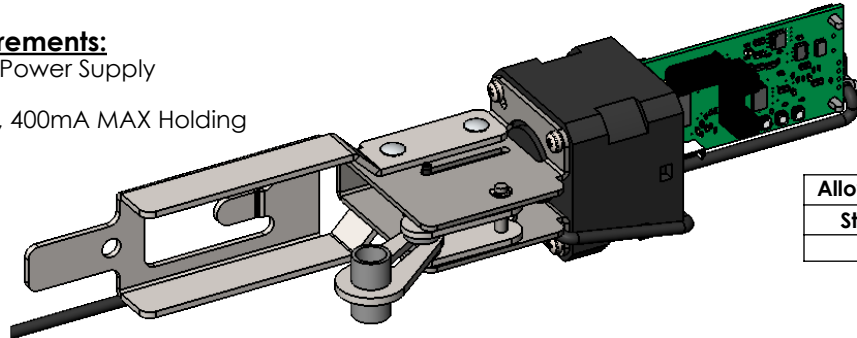

Allowable Cutoff From Device Length	
Standard 36"	Standard 48"
8.00"	14.00"

PROVIDES SIMULTANEOUS ELECTRIC LATCH RETRACTION AND DOGGING (TOUCH BAR DEPRESSED)

Installation:

1. Separate the rail from the touch bar assembly.
2. Separate the sub-plate from the front arm assembly.
3. Remove and discard the pivot bumper from the front pivot arm.
4. Attach the sub-plate to the front arm assembly.
5. Separate the rear arm assembly from the touch bar assembly.
6. Separate the sub-plate from the rear arm assembly and modify.
7. Remove and discard the pivot bumper from the rear pivot arm.

2-Conductor Wire Run	
Distance	Wire Gauge
70'	22
110'	20
180'	18
280'	16
450'	14
720'	12

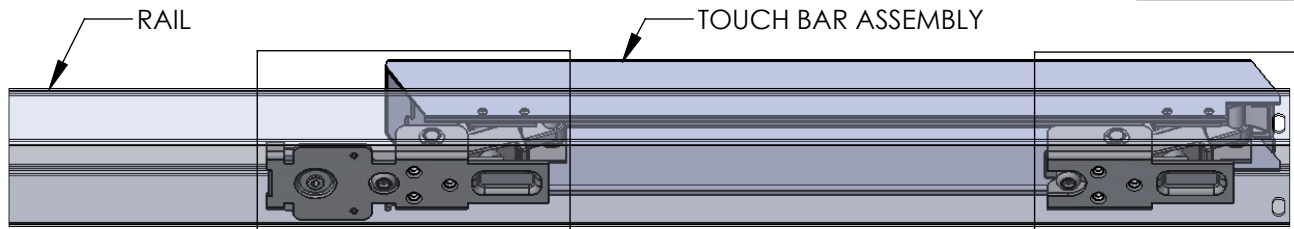

REAR ARM ASSEMBLY

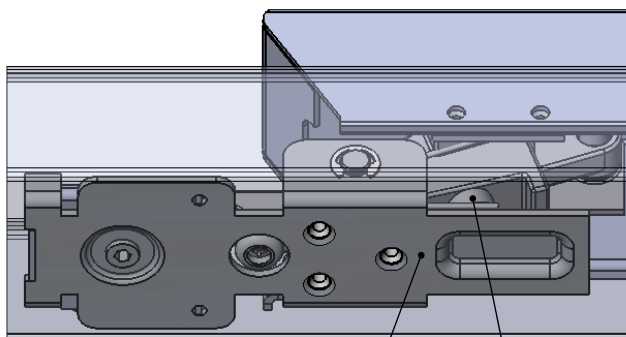

SUB-PLATE PIVOT BUMPER

FRONT ARM ASSEMBLY

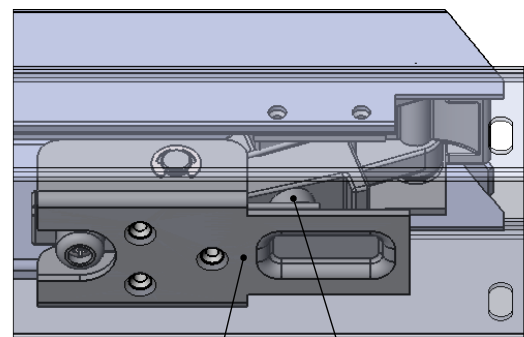

SUB-PLATE PIVOT BUMPER

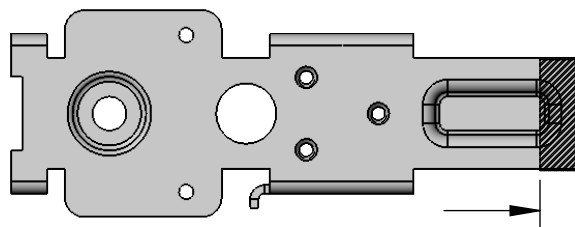

REMOVE 3/8" FROM SUB-PLATE

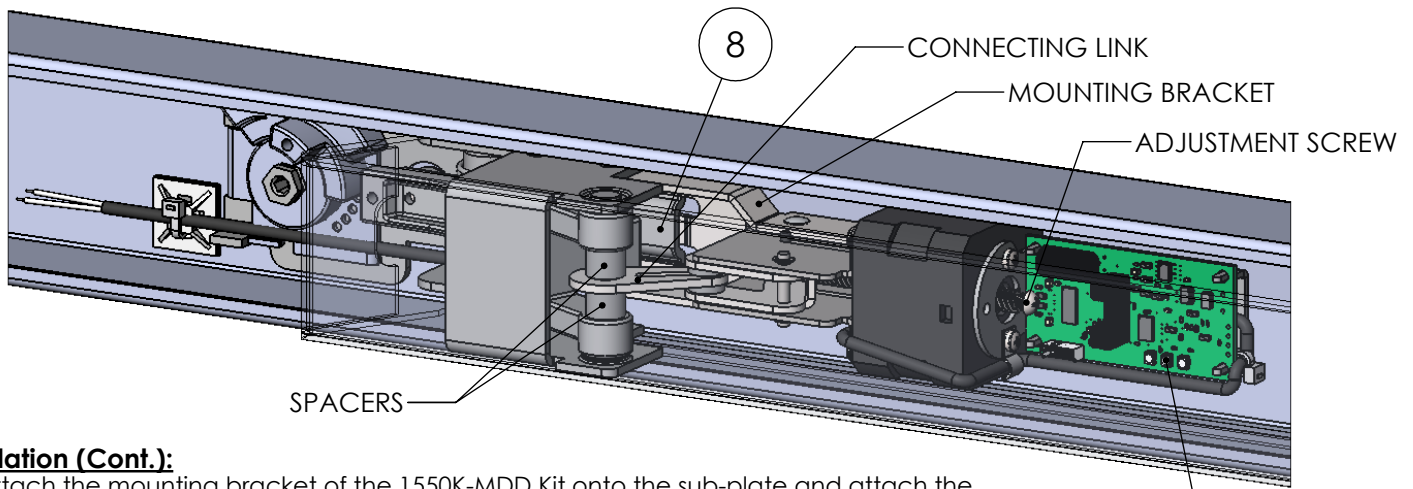

Installation (Cont.):

8. Attach the mounting bracket of the 1550K-MDD Kit onto the sub-plate and attach the sub-plate to the rear arm assembly.
9. Attach the connecting link and supplied spacers to the rear arm assembly.
10. Route the lead wires through the rear arm assembly.
11. Attach the rear arm assembly to the touch bar assembly.
12. Attach the rail to the touch bar assembly.
13. Secure the lead wires to the inside of the rail using the supplied ty-wrap mount and ty-wrap.
14. Apply the supplied technical assistance labels to the chassis cover and the end cap.

Do not remove any regulatory labels adhered to the device.

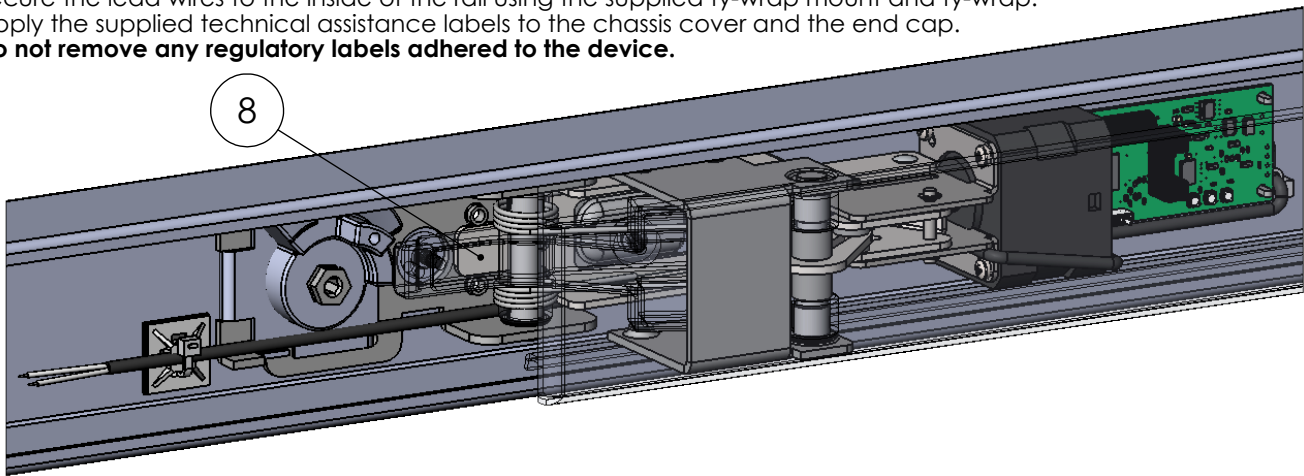

Motor Drive Electric Latch Retraction Adjustment:

1. Verify the device is properly adjusted for mechanical operation. Electric operation should not exceed the mechanical operation or there will be a high risk of damage to the device. **We suggest setting the latch retraction under electric operation at 1/16" less than the latch retraction under mechanical operation.**
2. Locate the adjustment screw in the rear of the motor assembly. Rotate the adjustment screw clockwise to increase the latch retraction or counterclockwise to decrease the latch retraction.

Onboard Indicator Light Assignments:

Maintain input power to the exit device and check the onboard indicator lights.

Remove input power before attempting a solution.

Green (Power)	Yellow (Sensor)	Red (Error)	Indication	Possible Solution
Off	Off	Off	No Power.	Connect the wiring between the power supply and the exit device.
On	On	Off	Normal Operation. The touch bar is retracted to the dogged position and dogged; the latch is retracted by default. The device is allowed 2 attempts.	
On	Off	On	Error in operation. The touch bar did not retract to the dogged position within 2 attempts.	Rotate the adjustment screw counterclockwise to decrease the latch retraction.
On	On	On	Error in operation. Without power being removed, the touch bar went from being dogged to unintentionally being extended, and then the touch bar did not retract to the dogged position within 2 attempts.	Clear the jam condition manually.
On	Blink	On	Error in operation. The touch bar did not extend from the dogged position when the power was last removed. The device will not attempt a retraction.	Clear the jam condition manually.
On	Simultaneous Blink		Error in operation. The input voltage dropped below the specification during operation.	Decrease the wire run or increase the wire gauge.
On	Alternating Blink		Error in operation. An electronics fault was detected.	An electronics replacement is required.