

LEFT HAND DOOR PREP

RIGHT HAND DOOR PREP

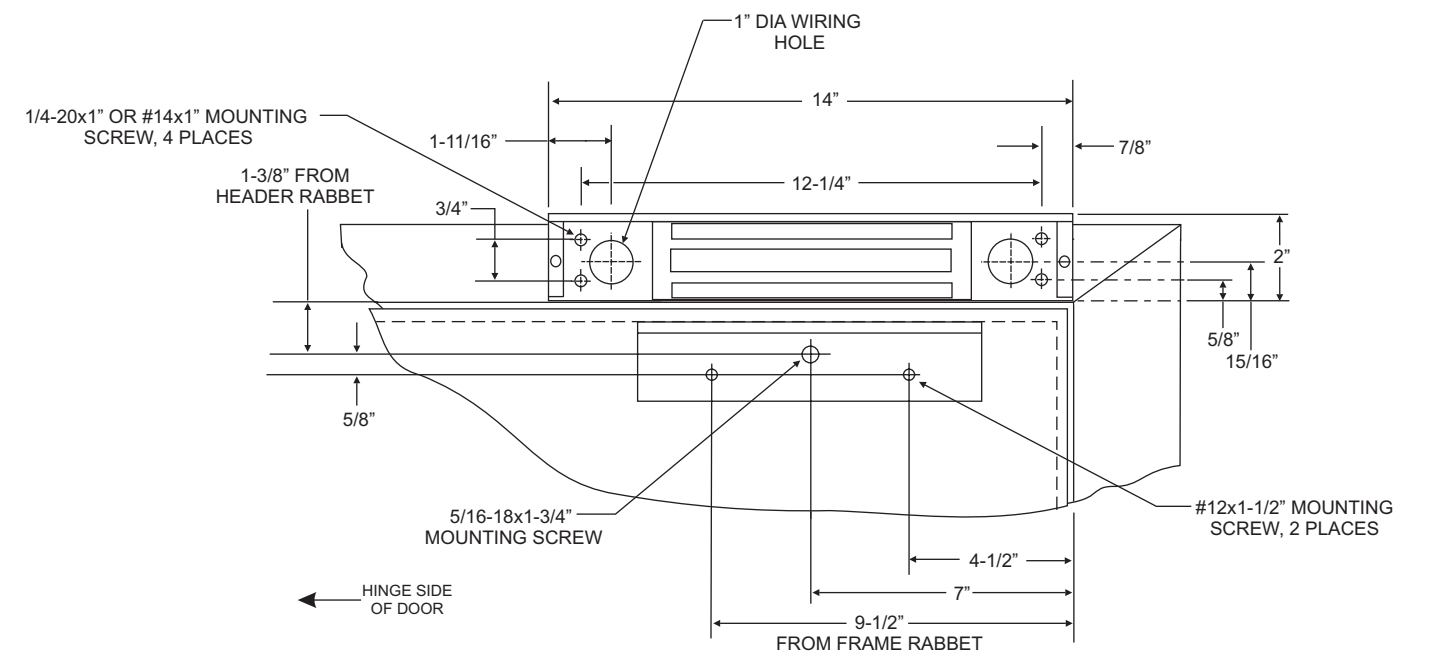
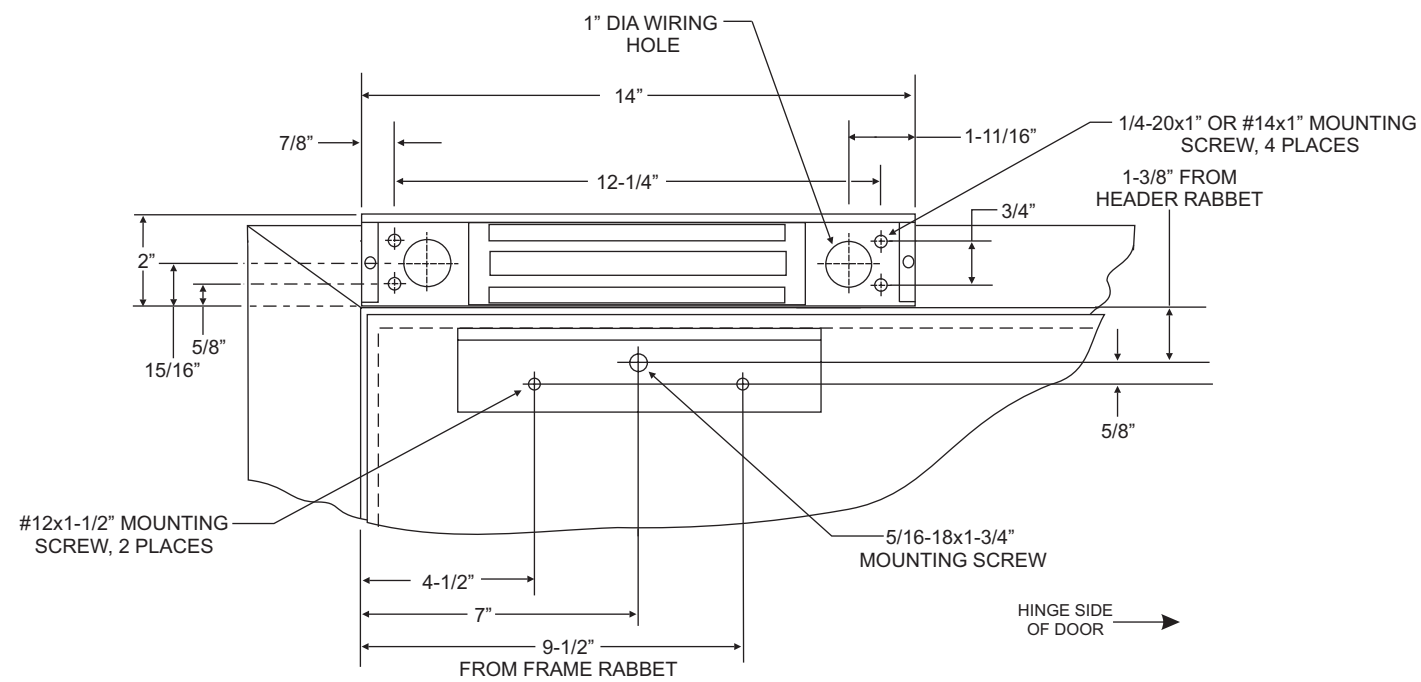
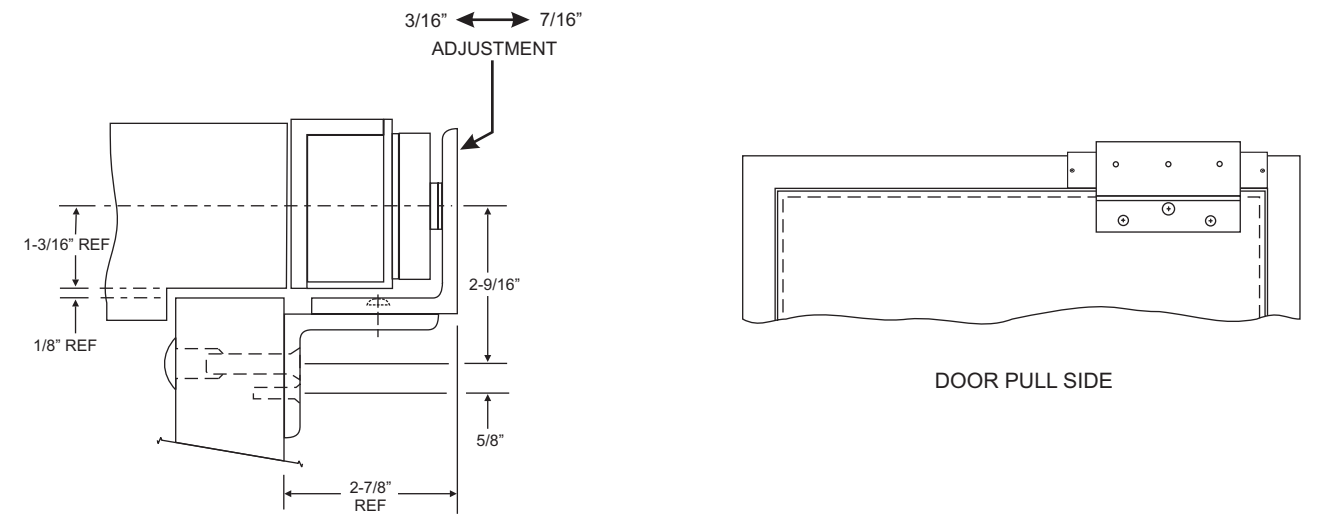
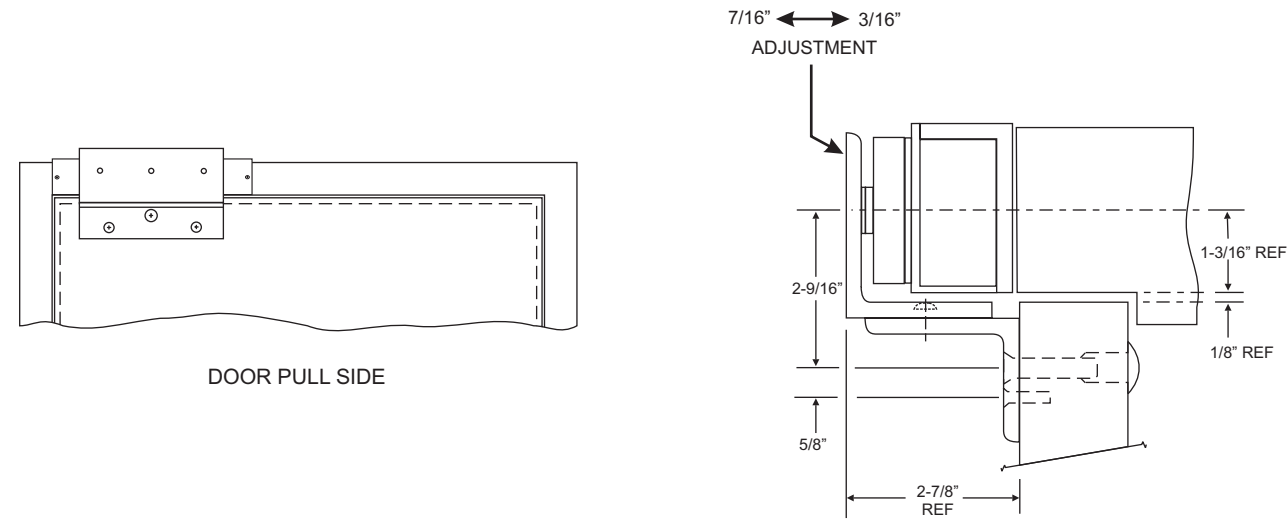

NOTES:

- #1- LOCK HOUSING MOUNTS FLUSH WITH HEADER AND FRAME RABBETS.
 - #2- ABOVE INFORMATION IS FURNISHED TO IDENTIFY LOCATIONS FOR REINFORCEMENT, IF REQUIRED.
- SEE INSTALLATION INSTRUCTIONS FOR DOOR AND FRAME PREPARATION.



DynaLock Corporation
705 Emmett Street • Bristol, CT 06010
Tel: (860) 582-4761 • Fax: (860) 585-0338

Template
Drawing

DRWN: MJL	Date: 5/13/05
CHK'D:	Date:
CHK'D:	Date:
APPV'D: JAS	Date: 7/5/05

Title: 2268-TJ10 SINGLE INSWING ELECTROMAGNETIC LOCK DOOR AND FRAME PREPARATION	
Page: 1 Of 1	Scale: —
Size: B	Drawing #: 301198
REV: —	