

INSTALLATION DESCRIPTION

The Series 2268-TJ20 is a 1200 pound holding force top jamb mounted electromagnetic lock designed to secure a double in-swinging pair of doors. The lock requires both installation procedures as described herein and in the separate wiring instructions included.

Typical installations of the lock on double-inswing doors:

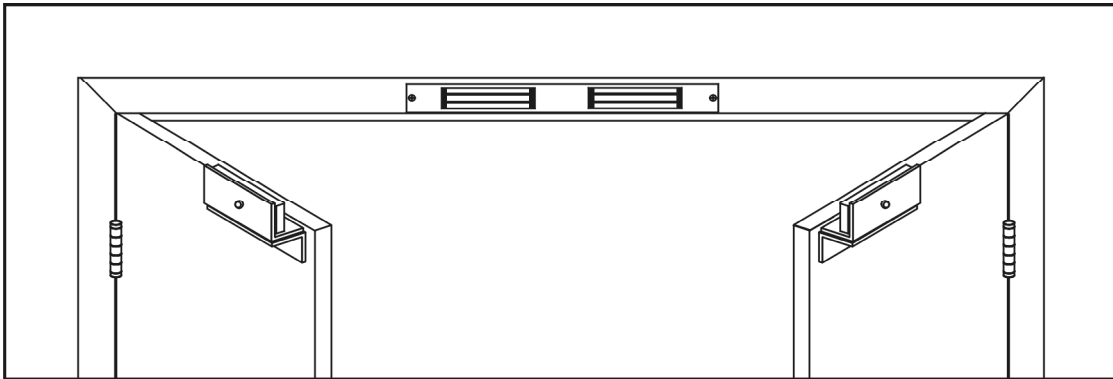

HANDLING

Care must be taken that the lock face and armature face are kept free of dirt, rust, paint, or any other obstruction which may interfere with the lock and armature making good contact. These faces may be cleaned with a nonabrasive pad and wiped with an oil dampened cloth.

MECHANICAL INSTALLATION

Familiarize yourself with the door and frame conditions. The lock must mount rigidly to the face of the door frame header. The door mounted armatures are supplied with adjustable mounting brackets and hardware that allows them to pivot slightly to compensate for reasonable misalignment.

NOTE: If this lock is supplied with the DSM2 feature be certain to mount the armatures so that the DSM block (magnet) extensions are aligned with the reed switches in the lock assembly.

ELECTRICAL INSTALLATION

After mechanical installation is complete the locks needs to be wired to a 12 or 24 VDC power source (AC requires rectifier option). Once low voltage power is supplied the unit is fully operational. All other wiring is for selected options. Refer to the separate wiring instructions included for further information.

MOUNTING CONSIDERATIONS

1. Individual door and frame conditions may vary. Dimensions shown at right are for a typical hollow metal door and frame.
2. The lock assembly should be mounted in the center of the opening for maximum performance. Verify that there is proper clearance for the lock assembly at the planned mounting location.
3. Electrical wiring for the locks must be routed through the back of the unit, through a hole drilled in the face of the frame header.

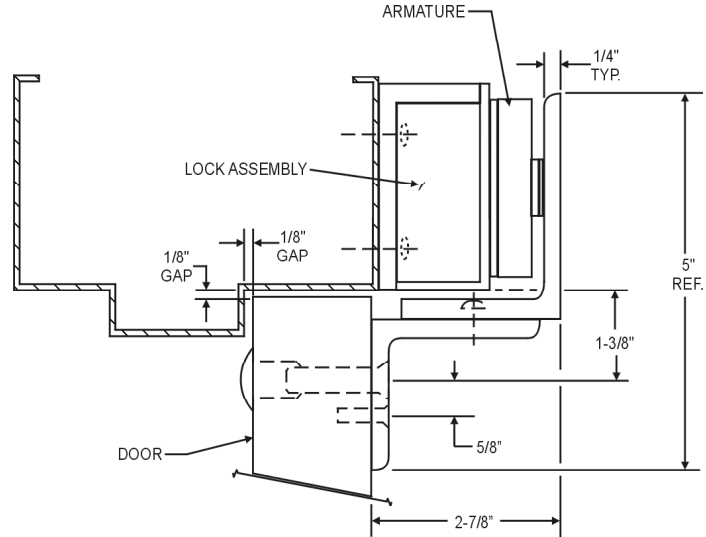

REMOVE LOCK HOUSING COVER

1. Remove two front and two bottom housing screws.
2. Remove housing cover.

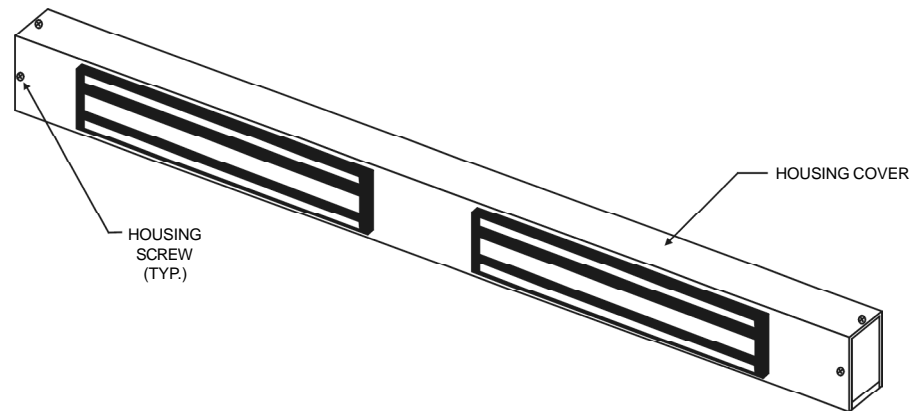

INSTALL THE LOCK ASSEMBLY

1. Standing at the "pull" side of the door, position the lock assembly on the face of the frame header as shown on the following page. Using prep drawing #301199, locate and mark the centers of the five mounting holes and either of the wiring holes.

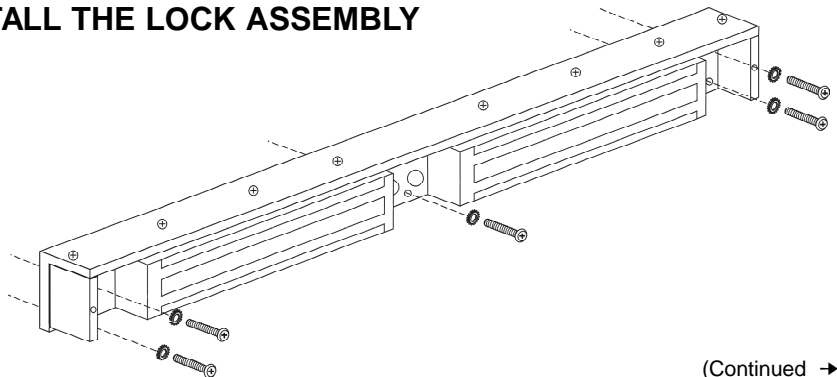

(Continued →)

2. Drill the marked holes in the face of the frame header.
 - a. Five (5) 3/16" diameter holes for #14 x 1" pan head sheet metal screws (use for wood or hollow metal frames)
OR
Five (5) 13/64" diameter holes and tap for 1/4-20 x 1" machine screws (use for reinforced metal frames)
 - b. One (1) hole for wiring. Openings are 3/4" - remember to protect wire from sharp edges.
3. Attach the lock assembly to the frame header using the appropriate screws and 1/4" external tooth lock washers.

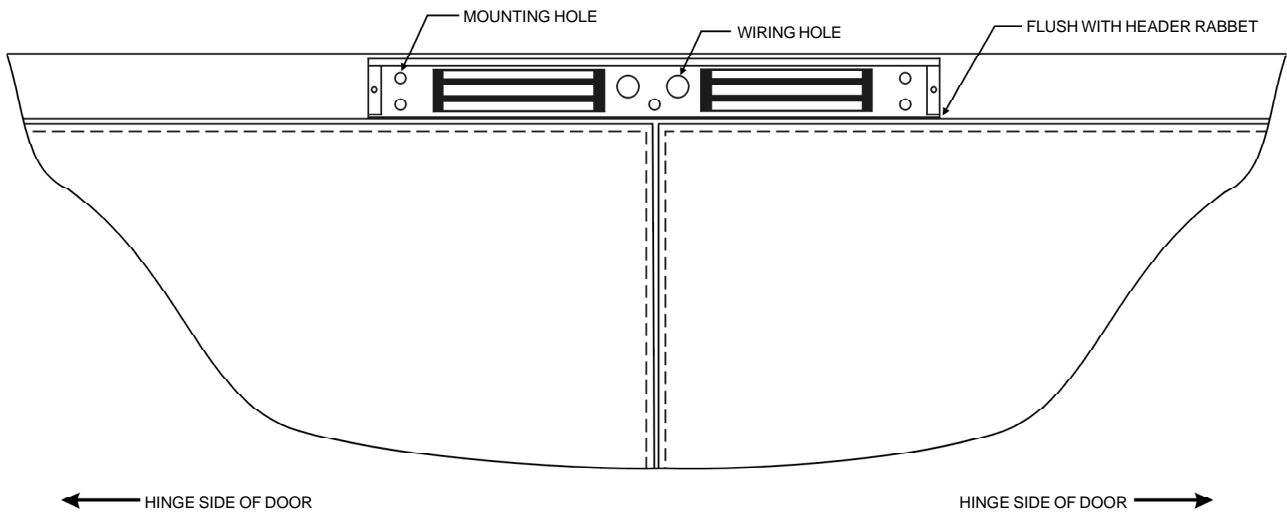

ASSEMBLE THE ARMATURE MOUNTING BRACKETS

1. Locate the armature mounting hardware from the hardware kit and attach the armature to the top armature mounting bracket as shown. Firmly tighten the armature mounting screw with the supplied 3/16" hex wrench.
2. Assemble the top and bottom armature mounting brackets together using the fasteners shown. Do not completely tighten the low cap allen screws at this time. The set screws can be threaded but do not tighten.
3. Repeat for second bracket assembly.

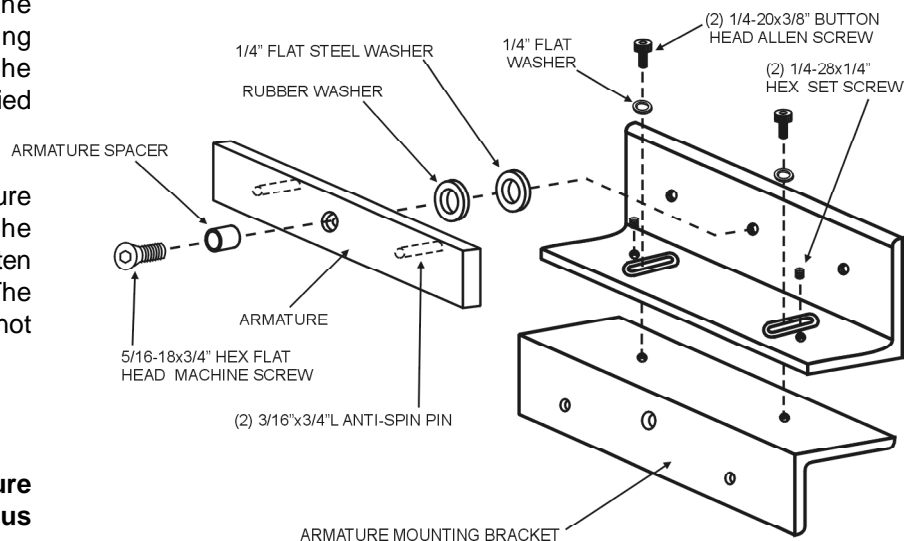

Failure to properly secure the armature to the bracket could result in serious injury or possible security breach.

INSTALL THE ARMATURE MOUNTING BRACKETS

1. Use the figures below to identify and mark the locations of the armature mounting bracket screw holes on the door. Refer to door and frame prep drawing #xxxxx for further information.

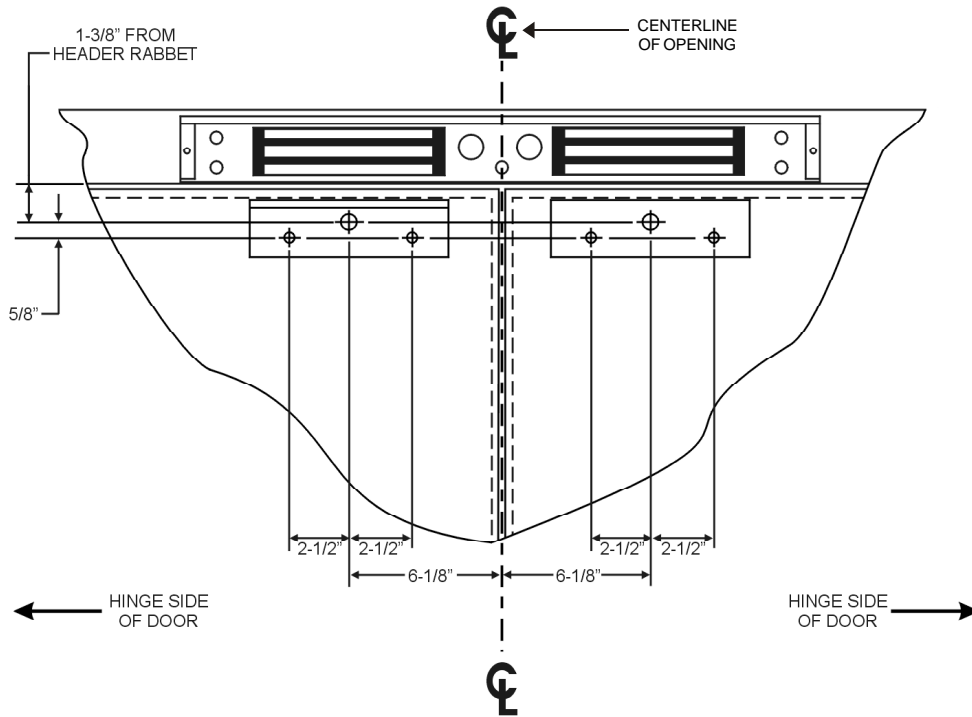

2. From the illustrations below select the one that resembles your door type and follow the instructions for drilling the three (3) armature mounting bracket screw holes.

GLASS & ALUMINUM OR HOLLOW METAL DOOR

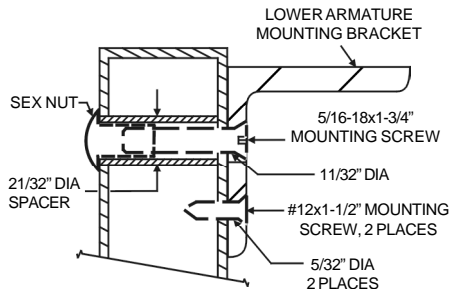

Drill a 11/32" diameter hole through door. From sex nut side only enlarge hole to 21/32" diameter. Drill two 5/32" diameter holes for lower mounting screws.

SOLID CORE DOOR

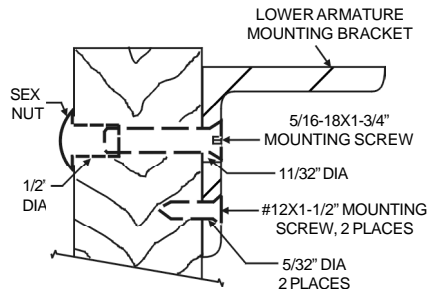

Drill a 11/32" diameter hole through door. From sex nut side only enlarge to 1/2" diameter for 1" depth. Drill two 5/32" diameter holes for lower mounting screws.

REINFORCED DOOR

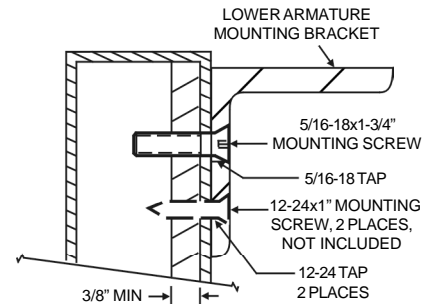

Drill a 17/64" diameter hole and tap for 5/16-18 thread. Drill two 11/64" diameter holes and tap for #12-24 thread.

(Continued →)

3. Mount the armature and mounting bracket assemblies to the doors using the appropriate hardware for your door types. Firmly tighten the mounting screws with a 3/16" hex wrench and phillips screwdriver.

ARMATURE ADJUSTMENT

1. On the first door, loosen the button head allen screws just enough as to allow the top armature bracket assembly to move in and out freely.
2. Close and latch the door. The mating surfaces of the lock and armature should fully contact each other. If necessary slide the armature in or out to ensure full contact is made with the lock while still allowing the door to properly close and latch.
3. When the desired adjustment is achieved slowly open the door, taking care to maintain the position of the armature. Firmly tighten the button head allen screws with a 3/16" hex wrench.
4. Tighten the two set screws with a 1/8" hex wrench.
5. Repeat for other door.

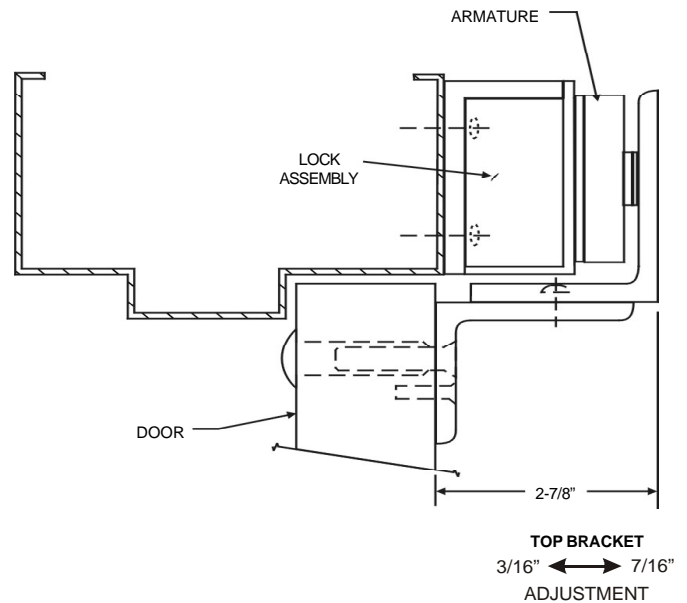

ASSEMBLE HOUSING COVER

1. Complete all wiring and connections. Refer to separate wiring instructions.
2. Replace the housing cover in the reverse order that it was removed.
3. Tighten the four screws.

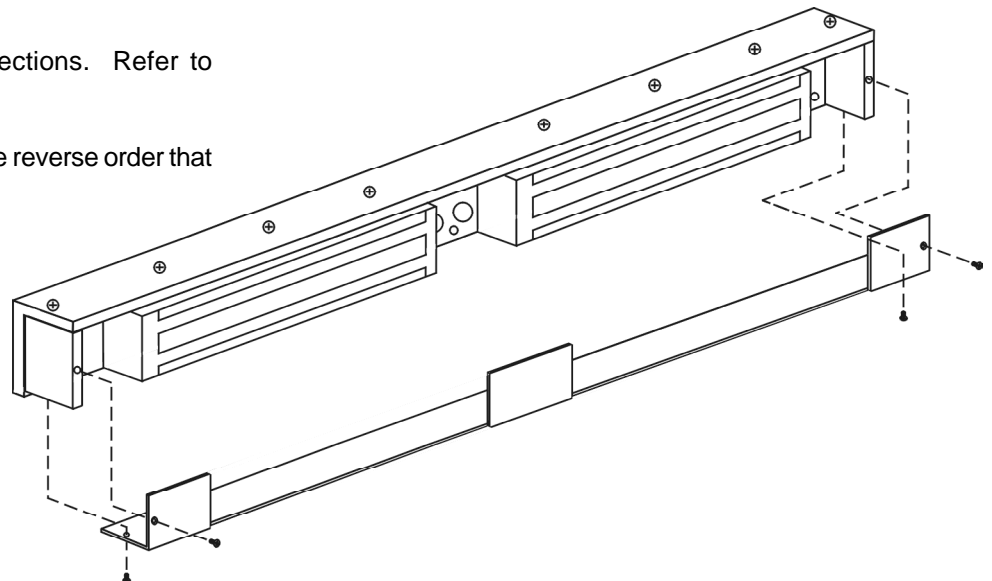



705 Emmett Street • Bristol, CT 06010
Ph/ 860.582.4761 • Fx/ 860.585.0338

**SERIES 2268-TJ20
ELECTROMAGNETIC LOCK
INSTALLATION INSTRUCTIONS**

EXPLODED PARTS VIEW LEGEND

Note: Refer to Page 7 for parts locations.

ITEM	DESCRIPTION	PART NO.	ITEM	DESCRIPTION	PART NO.
1	Lock Assembly	301191	11	5/16-18x3/4" Armature Screw	300588
2	Lock Housing Cover	301192	12	Rubber Washer	300003
3	1/4" External Tooth Washer	300971	13	1/4" Flat Steel Washer	300550
4	1/4-20x1" Machine Screw**	300972	14	3/16"x3/4" Anti-spin Pin	300586
5	8-32x3/8" Housing Cover Screw	300608	15	#12x1-1/2" Sheet Metal Screw	300600
6	Upper Armature Mtg. Bracket	301183	16	5/16-18x1-3/4" Machine Screw	300589
7	Armature	300968	17	Sex Nut	300004
8	Lower Armature Mtg. Bracket	301184	18	1/4" Flat Steel Washer	300550
9	1/4-20x3/8" Button Head Screw	301197	19	Door Spacer	300001
10	1/4-28x1/4" Set Screw	300604	20	Armature Spacer	300002

** #14 x 1" Sheet Metal Screws can also be used (PN# 300973)

EXPLODED PARTS VIEW

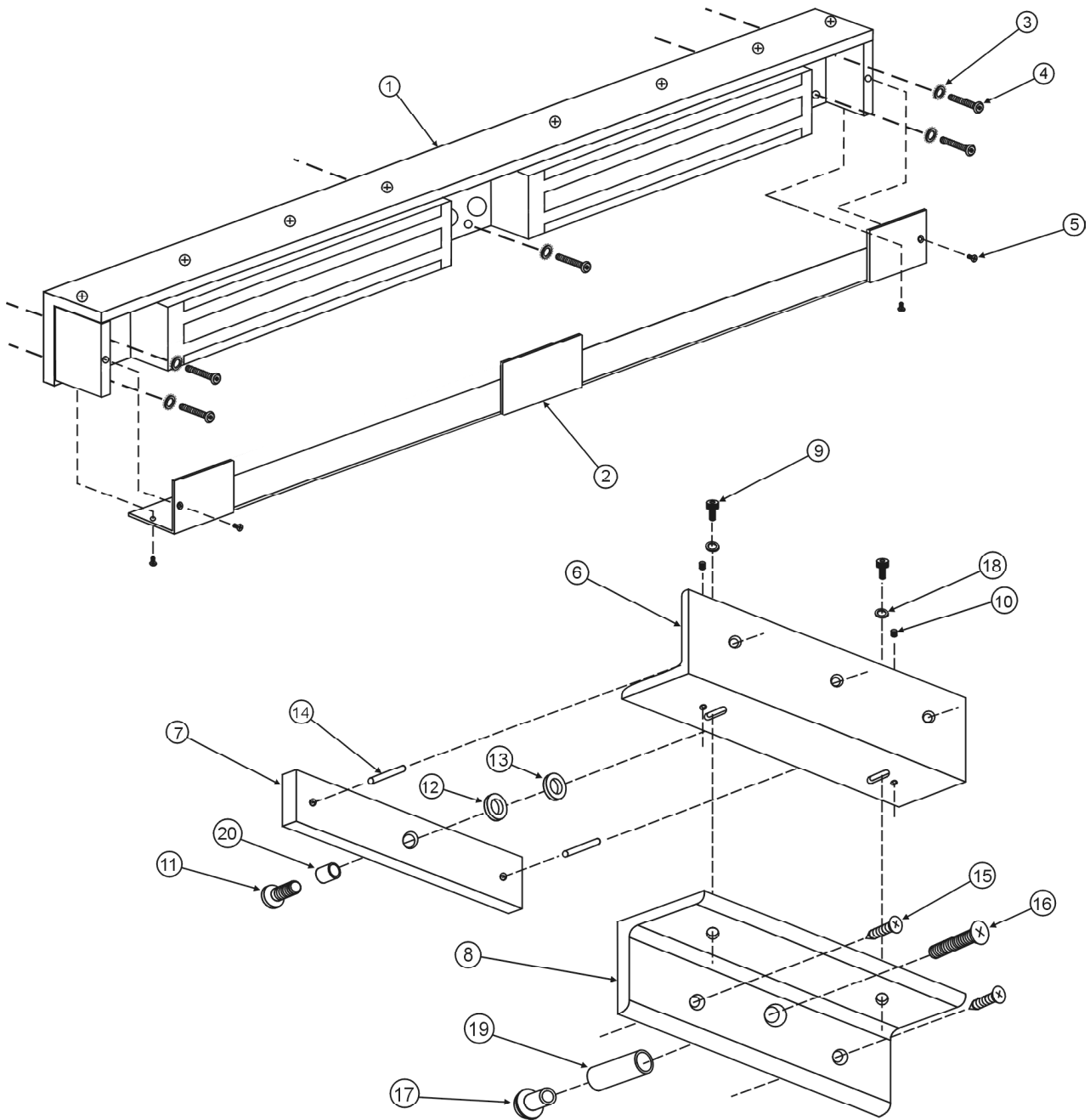

Note: Refer to Page 6 for parts legend.

**FOR PRODUCT SUPPORT AND PARTS
ORDERING INFORMATION CONTACT:**

DynaLock Corp.
705 Emmett Street
Bristol, CT 06010
Bus: (877) 396-2562 Toll-Free
(860) 582-4761
Fax: (860) 585-0338

DYNALOCK ON THE INTERNET:

E-mail: info@dynalock.com
Website: www.dynalock.com