

**PLEASE DELIVER THIS MANUAL
TO THE END-USER UPON COMPLETION
OF THE INSTALLATION**

**FOR PRODUCT SUPPORT AND PARTS
ORDERING INFORMATION CONTACT:**

DynaLock Corp.
705 Emmett Street
Bristol, CT 06010
Bus: (877) 396-2562 Toll-Free
(860) 582-4761
Fax: (860) 585-0338

DYNALOCK ON THE INTERNET:

E-mail: info@dynalock.com
Website: www.dynalock.com

INSTALLATION DESCRIPTION

The Series 3101C-TJ101 is a 1500 pound holding force delay egress top jamb-mounted electromagnetic lock designed to secure a single-inswinging door. The lock requires both installation procedures as described herein and in the separate wiring instructions included.

Typical installations of the lock on single-inswing doors:

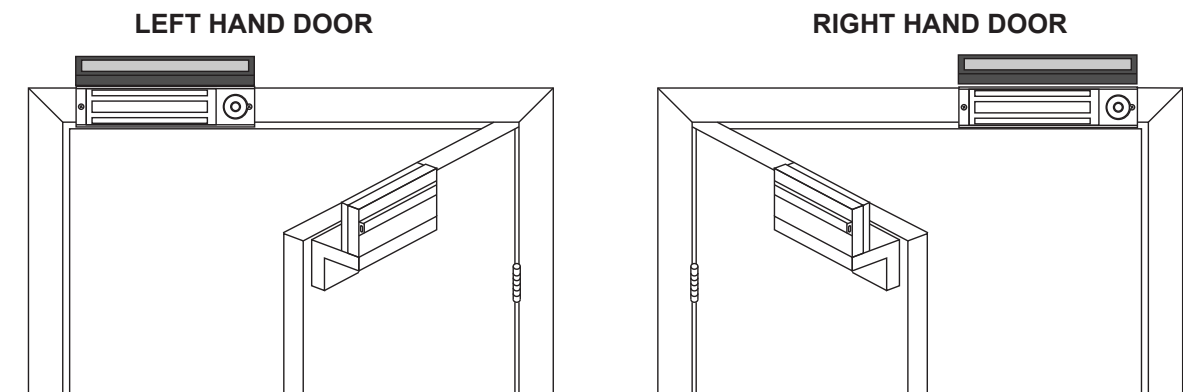

HANDLING

Care must be taken that the lock face and armature face are kept free of dirt, rust, paint, or any other obstruction which may interfere with the lock and armature making good contact. These faces may be cleaned with a non-abrasive pad and wiped with an oil dampened cloth.

MECHANICAL INSTALLATION

Familiarize yourself with the door and frame conditions. The lock must mount rigidly to the face of the door frame header. The door mounted armature is supplied with an adjustable mounting bracket and hardware that allows it to pivot slightly to compensate for reasonable misalignment.

NOTE: If this lock is supplied with the DSM option be certain that disc magnets are present inside the armature housing.

ELECTRICAL INSTALLATION

After mechanical installation is complete the lock needs to be wired to a 12 or 24 VDC/VAC power source. Once low voltage power is supplied the unit is fully operational. All other wiring is for selected options. Refer to the separate wiring instructions included for further information.

MOUNTING CONSIDERATIONS

1. Individual door and frame conditions may vary. Dimensions shown at right are for a typical hollow metal door and frame.
2. The lock assembly should be mounted closest to the strike jamb of the frame for maximum performance. Verify that there is proper clearance for the lock assembly at the planned mounting location.

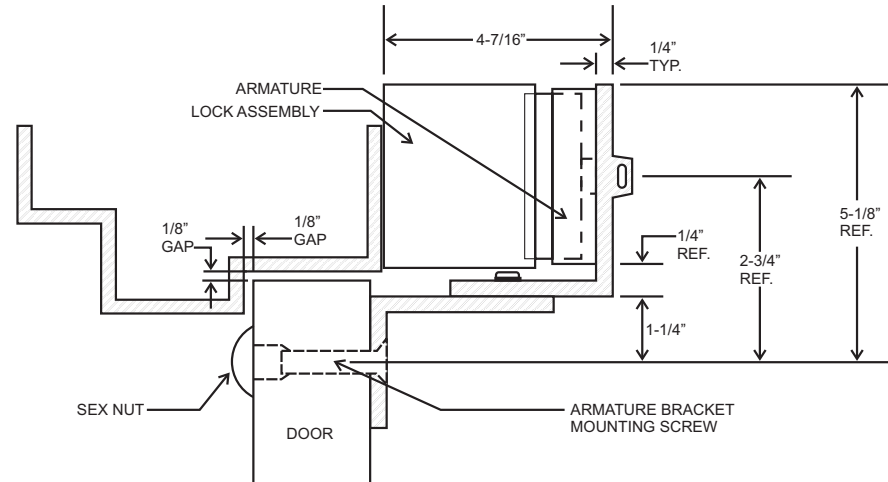

INSTALL THE LOCK ASSEMBLY

1. Drill out the four dimpled mounting hole locations inside the back of the lock housing using a 5/32" drill. Position the lock assembly on the face of the frame header, on the pull side of the door, as shown. Locate and mark the centers of the four mounting holes.
2. Drill the marked holes in the face of the frame header:
Four (4) 5/32" dia. mounting holes.
3. Attach the lock assembly to the frame header using four (4) #14-1½ pan head wood screws or 10/32 x 1¾ philip pan metal screws. Firmly tighten the screws using a #2 phillips screwdriver.

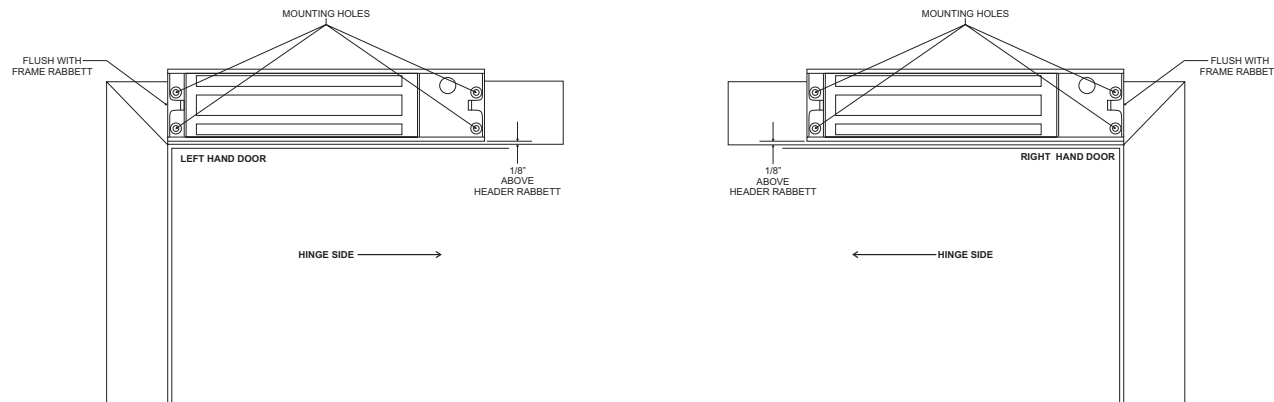
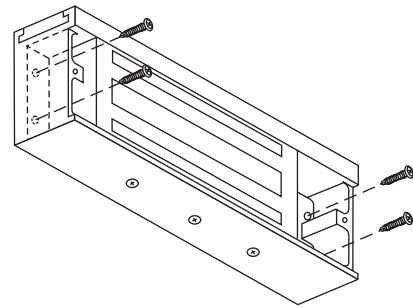

EXPLODED PARTS VIEW

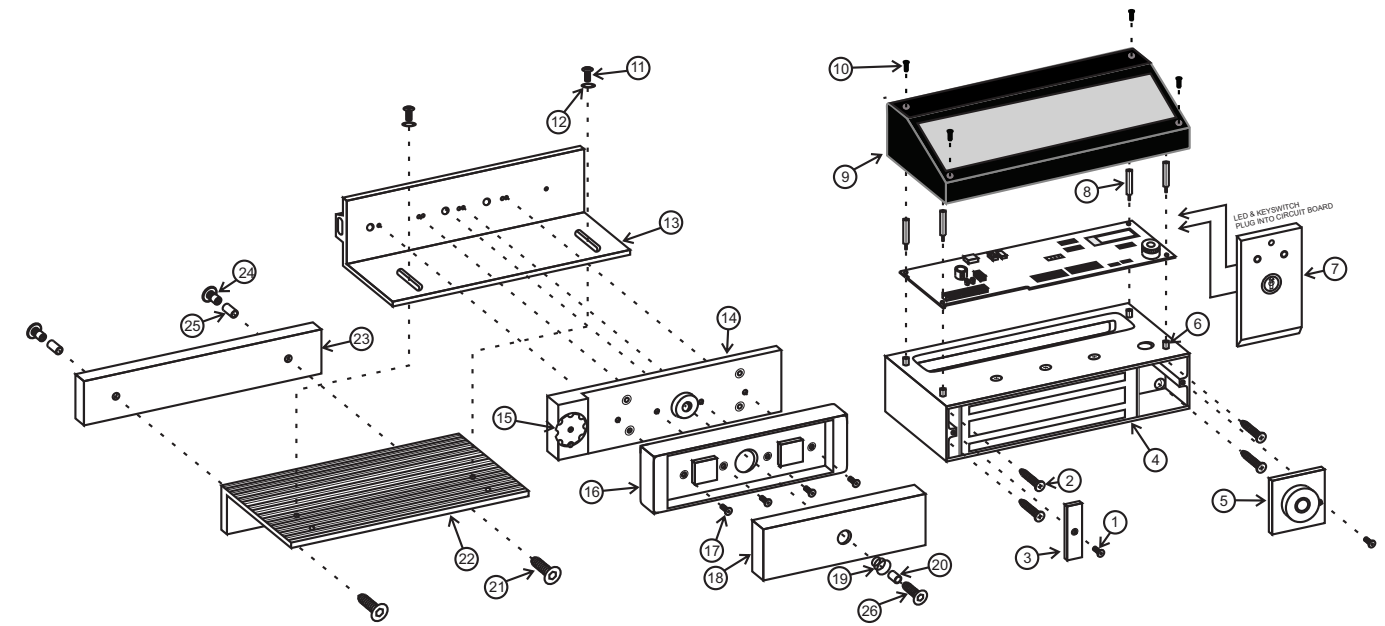

Note: Refer to Page 6 for parts legend.

EXPLODED PARTS VIEW LEGEND

ITEM	DESCRIPTION	PART #
**1	8-32 x 1/4" PHILIPS FLAT HEAD	300541
**2	#12 1 1/2" FLAT HEAD SCREWS	300600
3	END COVER	300010
4	LOCK HOUSING	N/A
5	ACCESS COVER / EGRESS SENSOR	301037
6	6-32 x 5/16" STANDOFFS	301231
7	7054xUS32D	N/A
8	6-32 x 7/8" STANDOFFS	301232
*9	ELECTRONICS COVER ASSY	N/A
10	PINTORX SECURITY SCREW	700174
**11	1/4-20 x 1/2" HEX BOLT	300738
**12	1/4" TOOTH LOCK WASHER	300742
13	UPPER ARMATURE BRACKET	301254
14	ARMATURE MOUNTING PLATE ASSEMBLY	301038
15	WHEEL KIT ASSEMBLY	301393
16	ARMATURE HOUSING	301334
**17	8-32 x 1/2" PHILIPS FLAT HEAD	301005
18	ARMATURE	300373
**19	ARMATURE SPRING	300753
**20	ARMATURE SPACER	300784
**21	5/16-18x2 1/4" FHS	300687
22	BOTTOM ARMATURE BRACKET	301260
23	3101B-TJ SPACER SHIM	301411
**24	SEX NUT	300004
**25	SPACER TUBE	300001
**26	5/16"-18x1" FHS TURNED	301033

* CONTACT FACTORY

** PART OF HARDWARE PACK 301563

Refer to Page 7 for parts locations.

ASSEMBLE THE ARMATURE MOUNTING BRACKET

Locate the two armature mounting bracket assembly screws and lock washers from the hardware kit and assemble the bracket as shown.

Firmly tighten the mounting screws with a 5/32" hex wrench. They may be loosened later for adjustment, as necessary.

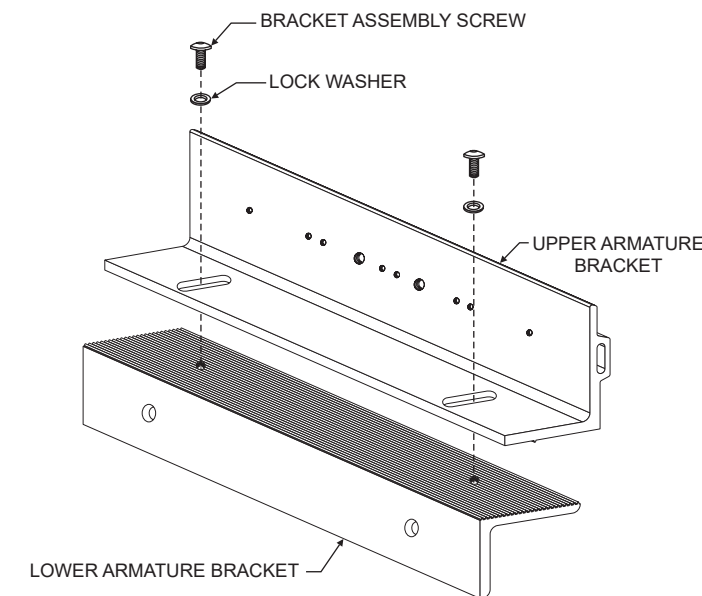

ATTACH THE ARMATURE TO THE ARMATURE MOUNTING BRACKET

Attach the Armature Housing to the top Armature Mounting Bracket as shown below. (See Exploded Parts View on page 7).

Failure to properly secure the armature to the bracket could result in serious injury or possible security breach.

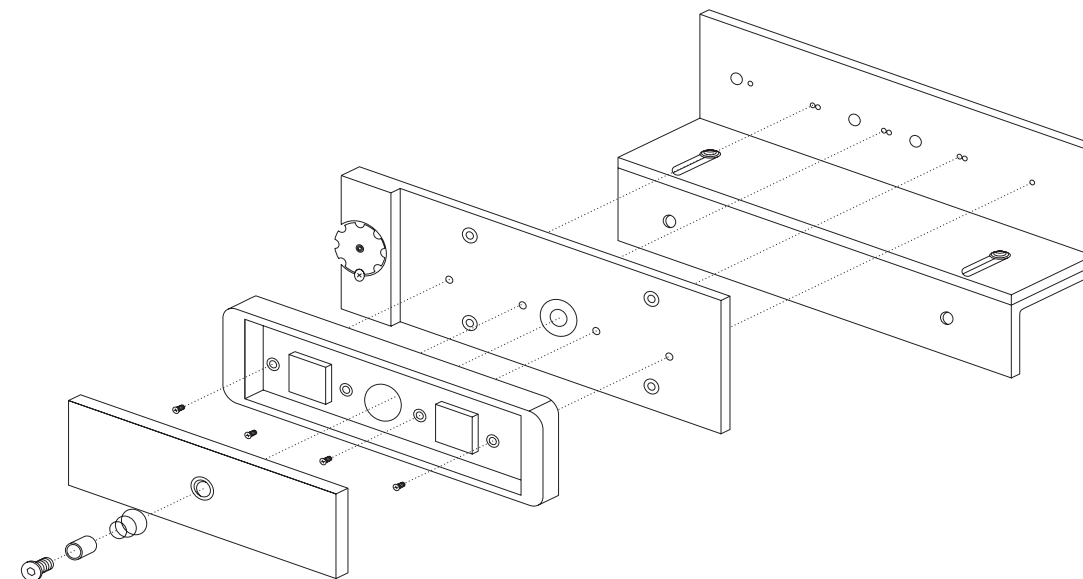

INSTALL THE ARMATURE MOUNTING BRACKET

1. Use the figures below to identify and mark the locations of the armature mounting bracket screw holes on the door.

Refer to door and frame prep drawing #301531 for further information.

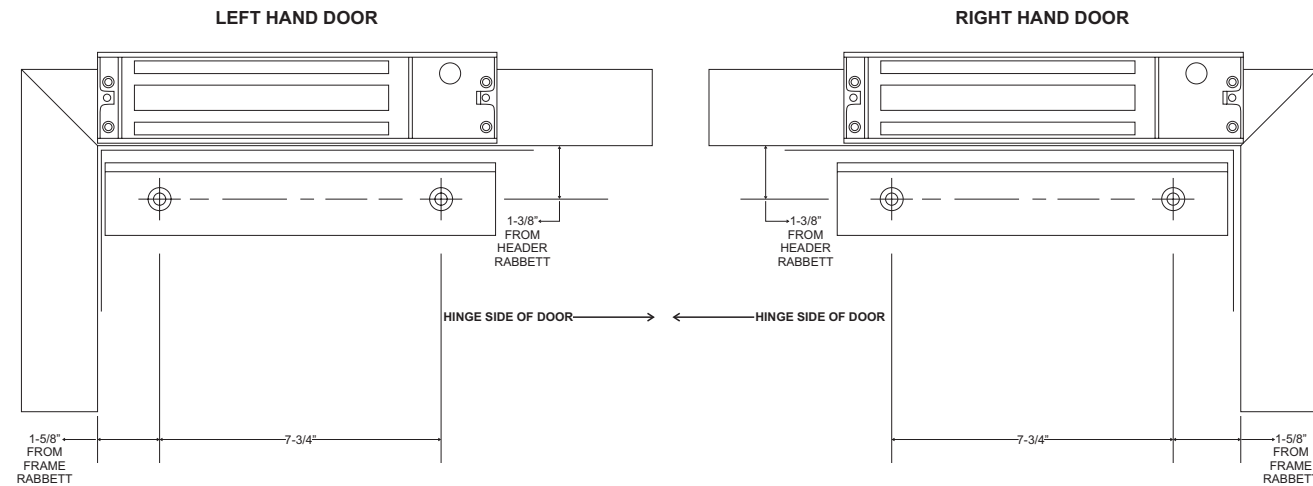

2. From the illustrations below select the one that resembles your door type and follow the instructions for drilling the two (2) armature mounting bracket screw holes.

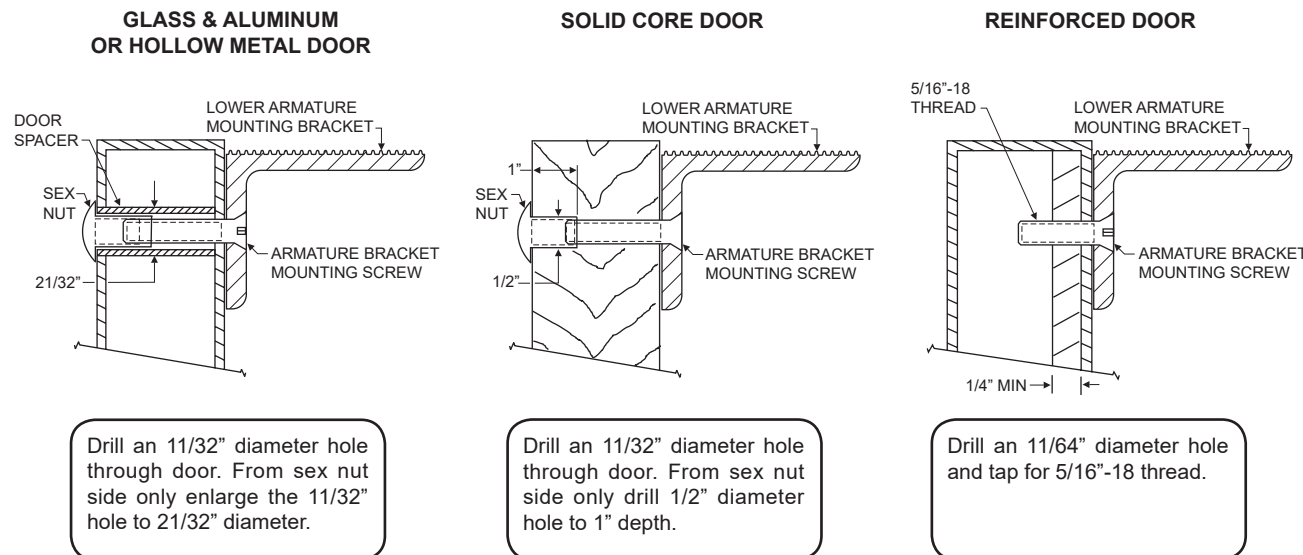

3. Mount the armature and mounting bracket assembly to the door using the appropriate hardware for you door type. Firmly tighten the mounting screws with a 3/16" hex wrench.

ARMATURE ADJUSTMENT

- Using a 5/32" hex wrench, temporarily loosen the armature bracket assembly screws roughly 1-1/2 turns to allow the upper armature bracket to move in and out freely (Ref. Figure "A").
- Close and latch the door. The mating surfaces of the lock and armature should fully contact each other. If necessary, slide the armature in or out to ensure full contact is made with the lock while still allowing the door to properly close and latch.
- When the desired adjustment is achieved, slowly open the door taking care to maintain the position of the armature. Firmly tighten the armature bracket assembly screws, making sure that the locking ribs on the upper and lower bracket halves properly mesh (Ref. Figure "A")

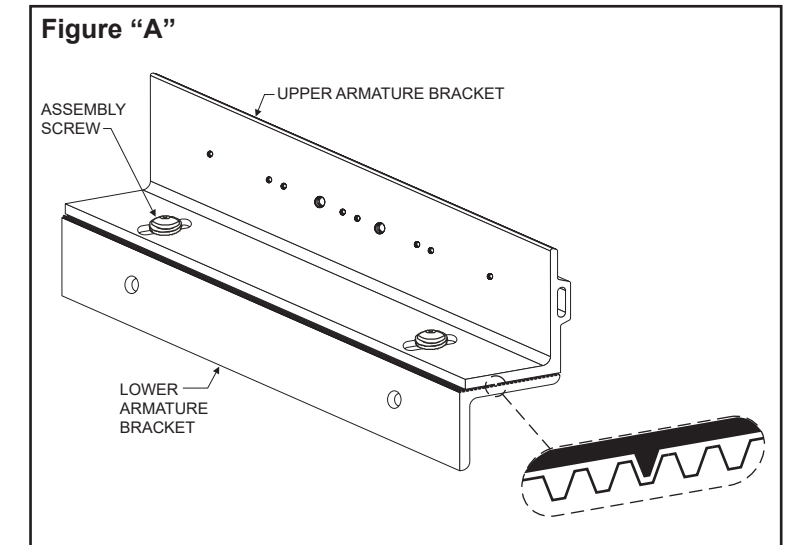

NOTE:

Make sure the door hits the frame just before the armature hits the maglock, to prevent loosening over time (armature not slamming against the lock).

