

# E0320 TOP PIVOT, CENTER HUNG, NON-HANDED

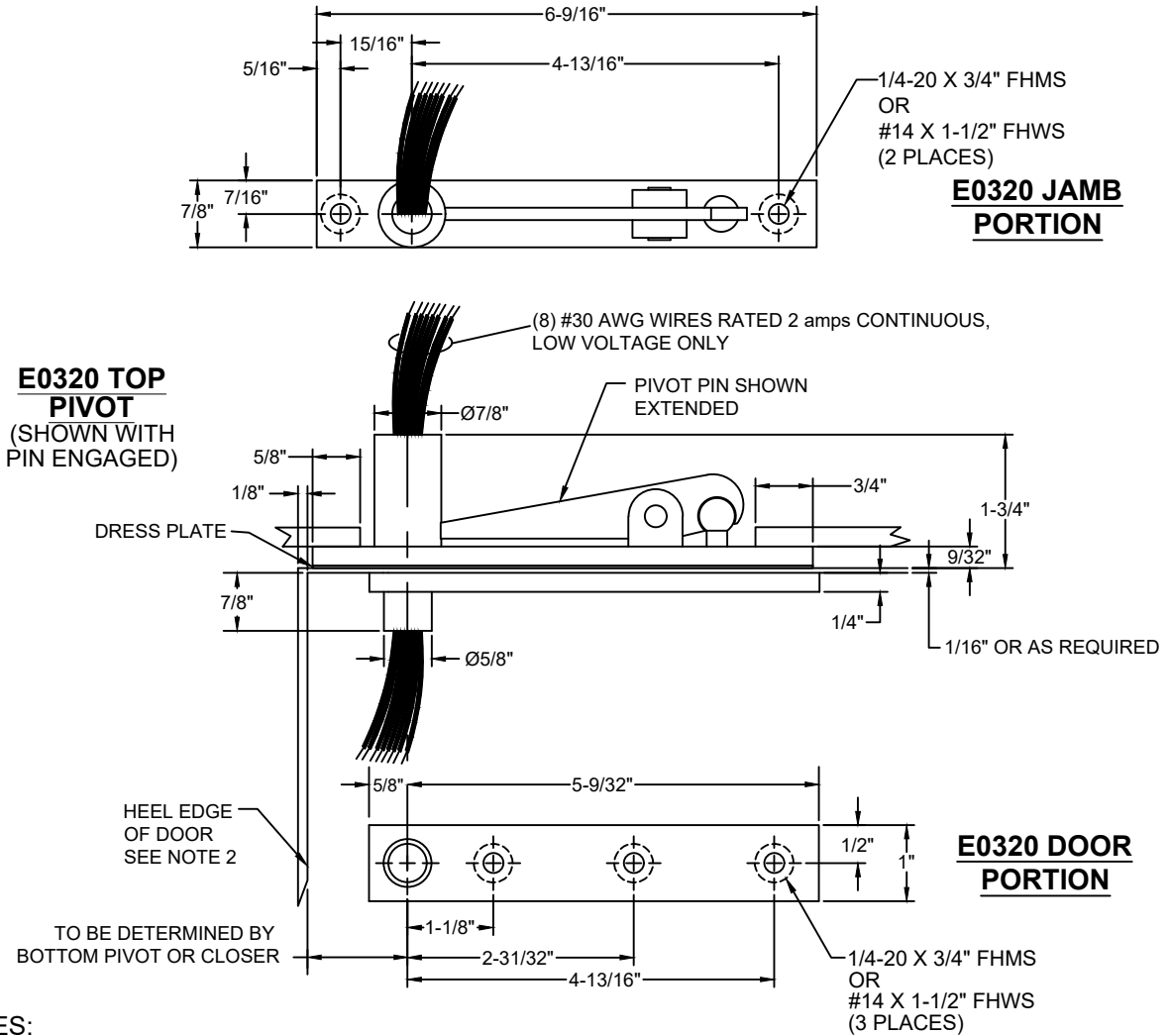

## NOTES:

1. REINFORCING BY OTHERS.
2. RADIUS HEEL EDGE OF DOOR 1-1/4" MAX FOR 1-3/8" - 2-1/2" THICK DOORS
3. IT IS THE DOOR AND FRAME MANUFACTURERS RESPONSIBILITY TO CHECK THE HARDWARE SCHEDULE AND PREP THE DOORS AND FRAMES.
4. CENTERLINE OF TOP PIVOT PIN MUST BE PLUMB AND STRAIGHT WITH BOTTOM PIVOT OR CLOSERSPINDE.
5. CONNECT WIRES IN THE FRAME AND INSTALL JAMB PORTION WITH PIN RETRACTED.
6. PLACE DOOR ON BOTTOM PIVOT AND LEAN THE TOP OF THE DOOR NEAR THE TOP JAMB.
7. INSTALL WIRES THROUGH DOOR PORTION BEARING HOLE AND CONNECT WIRES IN DOOR.
8. INSTALL DOOR PORTION.
9. RAISE DOOR TO VERTICAL POSITION WHILE CAREFULLY PUSHING WIRES DOWN INSIDE DOOR.
10. ENGAGE TOP PIVOT PIN BY TURNING ADJUSTING SCREW CLOCKWISE WHEN DOOR PORTION IS IN ALIGNMENT WITH THE JAMB PORTION.
11. TEST THE ELECTRICAL INSTALLATION FOR PROPER OPERATION OF THE WIRED DOOR DEVICES.

**Disclaimer:** This template is to be used for installation, as shown, of said product and is not suitable for every application method. Custom applications, where door sizes, weights and conflicting hardware are a factor, need to be addressed with ABH and proper instructions provided. ABH is not liable for failure or performance of the product due to improper installation methods and/or use. Improper use and/or installation of this product will void the standard warranty.

**ABH**  
MANUFACTURING INC.

www.abhmfg.com  
E-mail: abhinfo@abhmfg.com  
Architectural Builders Hardware Mfg., Inc.  
1222 Ardmore Ave., Itasca, IL 60143  
630.875.9900; FAX 800.9FAXABH (932.9224)

© 2020 ABH Mfg., Inc.  
printed in USA

E0320-05.DWG

**E0320**

PAGE 1 OF 1

REVISED 10-21-20