

**Installation Instructions for Catalog Series 96DV2(\*)-N5  
AdaptaBeacon® Signals**

**Description**

The catalog number 96DV2(\*)-N5 AdaptaBeacon signal is a UL listed small strobe light. The signals are suitable for indoor or outdoor (weatherproof) installation and have type 4X enclosure protection. They are suitable for installation in the Division 2 locations listed in Table 1.

These signals are designed for mounting on 1/2" (13 mm) NPT conduit.

**Electrical Specifications**

Rated Voltage ..... 120V 50/60 Hz  
Current ..... 0.10 Amp

**Installation**

Install in accordance with the latest edition of the *National Electrical Code* and local regulations.

 **WARNINGS**

**To reduce the risks of igniting hazardous atmospheres and electric shock, ensure that power is disconnected before installing the signal.**

**To prevent leakage and a potential shock hazard, when mounting outdoors the signal must be installed with the lens or dome facing directly up.**

1. Refer to Figure 1. The signals require 1/2" (13 mm) NPT conduit (not supplied). Route the 18" (457 mm) wire leads coming from the bottom of the signal mounting base through the conduit. Thread the conduit into the signal mounting base.
2. Using wire nuts (not supplied), connect field wiring to signal wiring. Connect the green ground wire leads using wire nuts (not supplied). Insert the wires into an appropriate electrical junction box.

**Troubleshooting**

If the strobe light fails to operate, make sure there is power to the signal. If there is power and the strobe still fails to operate, replace the strobe tube as directed in the Strobe Tube Replacement section.

**Maintenance**

*Cleaning*

 **CAUTION**

**To prevent damage to the lens, do not use abrasive materials or cleaners.**

Periodically clean the AdaptaBeacon lens surface, to maintain optimum light visibility. The lens may be cleaned with a soft cloth or sponge using water or a mild detergent solution. Ensure that the lens is completely dry before assembling the signal.

*Strobe Tube Replacement*

 **WARNINGS**

**To reduce the risks of igniting hazardous atmospheres and electric shock, ensure that power is disconnected before installing the signal. Do not connect power until installation has been completed and unit is tightly assembled and secured.**

**To prevent leakage and a potential shock hazard, use care when disassembling the signals to prevent tearing of the gaskets.**

Refer to Table 2 for the required strobe tube.

1. Refer to Figure 2. Remove the screw in the clamp ring, remove ring, and set aside. Carefully lift the lens straight up and off the signal mounting base, being careful not to damage the strobe tube or lens gasket. If the lens adheres to the gasket on the signal base **do not** force apart by hand but carefully pry the lens off using a thin blade screwdriver.

 **CAUTION**

**To prevent damage to the strobe tube, handle the strobe tube only by the base.**

2. Grasp the strobe tube by its base and pull straight up from its socket. Install the new strobe tube by aligning the connector on the base of the tube with the mating socket. Carefully press down into the socket.
3. Assemble the signal.
4. Turn on power and verify that the strobe operates.

\*The letter in this position signifies the color of the supplied lens. A - amber, B - blue, C - clear, G - green, M - magenta or R - red.

Table 1. Division 2 Locations

| Class | Division | Group      | Temp. Code         |
|-------|----------|------------|--------------------|
| I     | 2        | A, B, C, D | T3C (160°C, 320°F) |
| II    | 2        | F, G       | T6 (85°C, 185°F)   |
| III   |          |            | T6 (85°C, 185°F)   |

Table 2. Replacement Parts

| Component   | Catalog Number or Part Number |
|-------------|-------------------------------|
| Strobe tube | 91B-ST                        |
| Lens        | 96-L(*)                       |

\*The letter in this position (A - amber, B - blue, C - clear, G - green, M - magenta or R - red) signifies the color of the lens; for example, a red lens for the 94DV2 series signal is 93-LR.

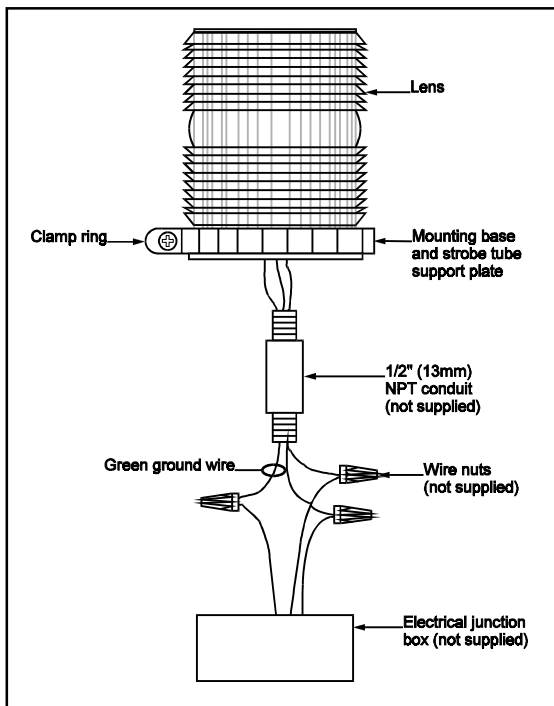

Figure 1. Conduit Mounting

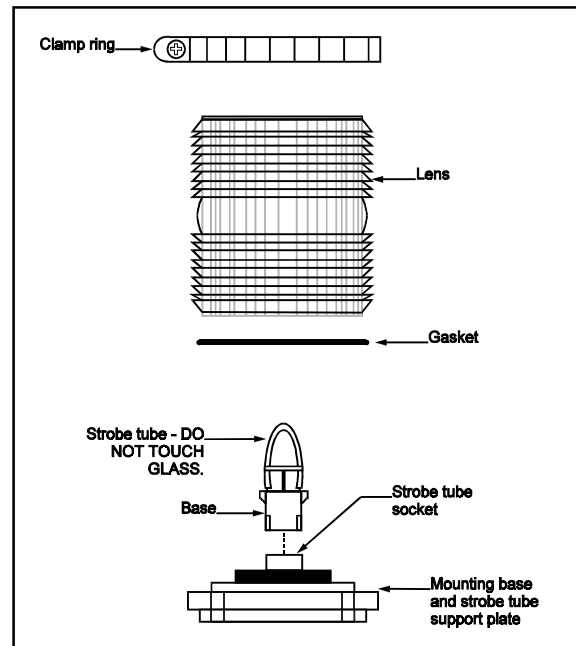

Figure 2. Strobe Tube Replacement