

Field Notes Bulletin

Edwards Signaling: Electromechanical Noise on Hazardous Location Horns

Introduction

In a previous AE Bulletin (040510), the effects of electromechanical devices on fire alarm signaling circuits was discussed. This bulletin will revisit what was covered on the first one, and to offer some additional information and suggestions.

Issue

Electromechanical devices, such as bells and explosion proof horns, can generate a lot of electrical “noise” on the wires they are connected to when they are operating. This noise can cause random troubles on fire alarm panels and booster power supplies as well as other electronic signals, including strobes that may not flash properly. To help alleviate this problem, there are some preliminary steps that should be taken.

Solution

Edwards offers a bipolar transient protector, part number 235196P, which should be installed across the incoming plus and minus of the first electromechanical device on a NAC (signal circuit). In addition, the device should be located at least 10 feet away (physically, not just wire length) from the fire alarm panel or booster power supply (see Figure 1).

Figure 1: Bipolar transient protector

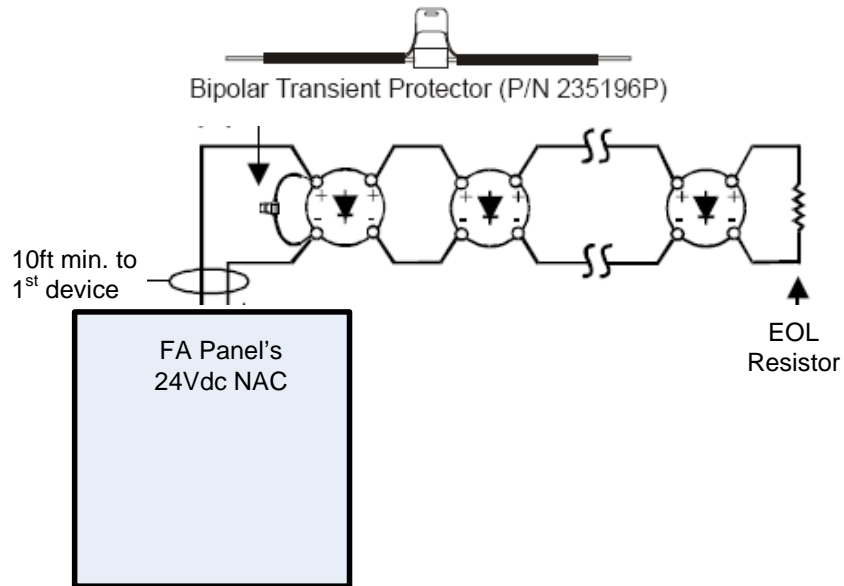

Wiring for electromechanical devices should also be separated from any electronic type devices, such as strobes, as much as possible. This means they should be on their own NACs, and the wiring should not be run in the same conduit or share junction boxes with wiring for electronic devices. The electrical noise could be induced into the other circuit's wire if they are not kept apart. If a protected area within a building requires both a horn and strobe, the two devices should also not be mounted right next to each other.

While the above steps should help in most cases, it may not in all. Depending on the installation, the devices used, and the panels they are connected to, additional measures such as longer wire separation between panel and devices, or even using twisted pair wire for the NAC, may be required.

Contacting support

Tel +1 800 336 4206
Fax +1 860 284 3083
signaling.techsupport@fs.utc.com
edwardssignaling.com