

## Base Device for Emergency Stop and Safety Gate Applications

- Basic device to EN 60204-1 and EN 954 -1
- Safety category 4 to EN954-1
- Stop category 0 to EN 60204-1
- Manual or automatic start
- Cross monitoring
- Feedback circuit for monitoring external contactors
- 3 enabling current paths
- Equivalent and non-equivalent activation

### Front View

SUPPLY LED green Power Supply  
K1 LED green Relay K1  
K2 LED green Relay K2



### Safety Instructions

Only trained professional electricians may install, start-up, modify, and retrofit this equipment! Disconnect the device / system from all power sources prior to starting any work! If installation or system errors occur, line voltage may be present at the control circuit in devices without DC isolation! Observe all electrical safety regulations issued by the appropriate technical authorities or the trade association. The safety function can be lost if the device is not used for the intended purpose. Opening the housing or any other manipulation will void the warranty.



### Caution!

Perform the following precautionary steps prior to installation, assembly, or disassembly:

1. Disconnect supply voltage to the equipment / system prior to starting any work!
2. Lockout/tag the equipment / system to prevent accidental activation!
3. Confirm that no voltage is present!
4. Ground the phases and short to ground!
5. Protect against adjacent live components using guards and barriers!
6. The devices must be installed in a cabinet with a protection class of at least IP 54.



### Caution!

Limited contact protection! Protection type according to DIN EN 60529.  
Housing/terminals: IP 40/ IP 20.  
Finger-proof acc. to VDE 0660 Part 514.

### Description of Device and Function

This device is a two-channel safety switching device with self-monitoring on each ON-OFF cycle. It conforms to EN 60204-1 and is equipped with positively driven relays. It is intended for monitoring connected switching elements on separating safety devices and generating a safety-oriented output signal (enable). Depending on the design, separating safety devices may include protective screens, safety doors, enclosures, covers, screens, etc.

**Basic function:** After supply voltage has been connected to terminals A1/A2 and the safety inputs closed, operating the reset button closes the enabling current paths (manual start). When the safety inputs are opened the enabling current paths will open.

### Operating modes / system functions

- **Two-channel activation** The device uses two-channel activation. With equivalent activation safety channel CH1 is connected via positive potential, safety channel CH2 via negative potential. With non-equivalent activation both safety channels are connected to positive potential.
- **Cross monitoring** With equivalent activation cross monitoring is achieved by means of the short-circuit principle; with non-equivalent activation it is achieved through functional diversity.
- **Manual start** When the safety inputs are closed, a button is used to close reset input S34 and then open it again (triggering with falling edge) or to close reset input S35 (triggering with rising edge).
- **Automatic start** Reset input S35 is connected to S33/S14. The device starts with the rising edge of the signal on safety input S14.
- **Starting lockout** After supply voltage has been connected and the safety inputs closed, the enabling paths will not close. Starting is only possible after the reset button has been operated. For starting lockout the reset inputs have to be activated with the button, as in manual start mode.
- **Restarting lockout** No restart after the safety inputs have been opened and closed. Restarting is only possible after the reset button has been operated. For restarting lockout the reset inputs have to be activated with the button, as in manual start mode.
- **Synchro-check** Synchro-check is only possible in automatic start mode (bridge S33/S14 - S35). After safety channel CH1, safety channel CH2 must close (S24) or open (S22) within the synchronous time  $t_s$ . If CH2 closes or opens before CH1, the synchronous time  $t_s = \infty$ .

Please observe instructions from safety authorities.

Proper Use

The devices are safety switching devices. They must only be used as components of safety equipment on machines intended to protect persons, material and plant.

Notes

- The safety category acc. to EN 954-1 depends on the external circuitry, the choice of control devices and their location on the machine.
- The indicated times must be observed when the device is operated, otherwise the device could lock. Locking can be cancelled by opening the safety inputs properly.
- SNE expansion devices or external contactors with positively driven contacts can be used to duplicate the enabling current paths.
- The device and the contacts must be protected at max. 6 A utilization category gG.
- The devices are equipped with overload protection (for short-circuit). After the malfunction has been dealt with, the device is operational again in approx. 3 s.
- Control output S13 is exclusively for connecting control devices as defined in the operating instructions and not for connecting external consumers such as lamps, relays or contactors.

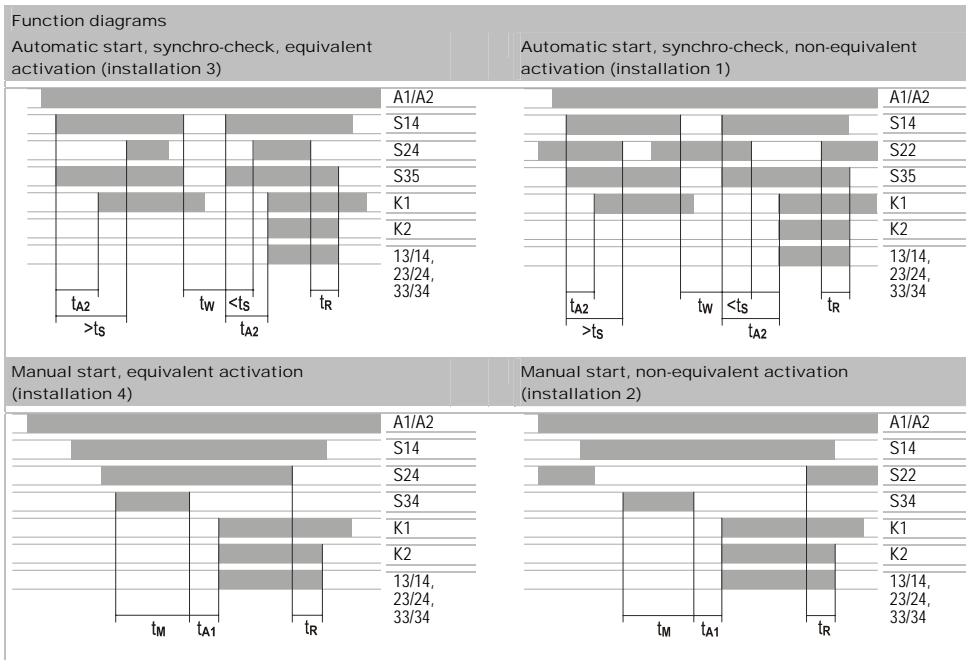

$t_M$  = Min. ON time  
 $t_{A1} / t_{A2}$  = Operate time  
 $t_S$  = Synchronous monitoring time  
 $t_W$  = recovery time  
 $t_R$  = release time

Technical data	
<b>Power circuitry</b>	
Rated voltage $U_N$	AC/DC 24 V, AC 115 – 120 V, AC 230 V
Rated power DC	2.0 W
Rated power AC	2.6 W / 3.2 VA
Residual ripple $U_{ss}$	2.4 V
Rated frequency	50 ... 60 Hz
Operating voltage range	0.85 ... 1.1 x $U_N$
Protection for control circuit supply	Short-circuit-proof (DC devices: PTC thermistor / AC devices: short-circuit-proof transformer)
<b>Control circuit</b>	
<b>Outputs S13, S23</b>	
Rated output voltage S13, S23	DC 22 V
No-load voltage AC device	< 40 V
Output current	100 mA
Short-circuit-proof / current limiting	Yes / No
<b>Inputs S14/S33, S22, S24, S34, S35</b>	
Input voltage range (for external supply, only on DC devices)	DC 17.4 V to DC 26.4 V
Rated current / peak current S14/S33, S22, S24	40 mA / 100 mA
Rated current / peak current S34, S35	5 mA / 50 mA
<b>Times</b>	
Permissible test pulse time $t_{TP}$ / test frequency	$\leq 1000 \mu\text{s}$ / $\leq 10 \text{ s}^{-1}$
Operate time $t_{A1}$ S34	20 ms to 40 ms
Operate time $t_{A2}$ S35	200 ms to 600 ms
Operate time $t_{A3}$	100 ms to 400 ms
Min. ON time $t_W$ S34, S35	> 80 ms
Synchronous time $t_s$ CH1 before CH2	approx. 200 ms
Recovery time $t_W$	$\geq 100 \text{ ms}$
Release time $t_R$ K1, K2	< 25 ms
<b>Output circuit</b>	
<b>Enabling paths</b>	
Contact equipment	3 NO contacts, positively driven
Rated switching voltage $U_N$	AC 230 V / DC 300 V
Max. continuous current $I_n$ per current path	6 A
Max. total current for all current paths	AC/DC 24 V 12 A AC 115 - 120 V, AC 230 V 8 A
Utilization category according to IEC 947-5-1	AC-15: $U_e$ 230 V, $I_e$ 4 A (360 h <sup>-1</sup> ) DC-13: $U_e$ 24 V, $I_e$ 4 A (360 h <sup>-1</sup> ) AC-15: $U_e$ 230 V, $I_e$ 3 A (3600 h <sup>-1</sup> ) DC-13: $U_e$ 24 V, $I_e$ 2.5 A (3600 h <sup>-1</sup> )
Mechanical service life	$10 \times 10^6$ switching cycles
<b>General data</b>	
Clearance/creepage distance between circuits	EN 60947-1:12.99
Overvoltage category	III
Rated impulse withstand level	4 kV
Contamination level of device: inside / outside	2 / 3
Rated voltage	300 V
Power-frequency test voltage	2 kV
Protection class to DIN VDE 0470 Part 1: housing / terminals	IP 40 / IP 20
Ambient / storage temperature	-25 ... +55 °C / -25 ... +75 °C
Climatic application class	H V G to DIN 40040: 04:87
Weight	DC device 0.21 kg AC device 0.25 kg
<b>Terminals and connection</b>	
Single-core or finely stranded	1 x 0.14 mm <sup>2</sup> to 2.5 mm <sup>2</sup> 2 x 0.14 mm <sup>2</sup> to 0.75 mm <sup>2</sup>
Stripping length	max. 8 mm
Finely-stranded with wire-end ferrule to DIN 46228	1 x 0.25 mm <sup>2</sup> to 2.5 mm <sup>2</sup> 2 x 0.25 mm <sup>2</sup> to 0.5 mm <sup>2</sup>
Max. tightening torque	0.5 to 0.6 Nm
For UL and CSA applications	Conductor sizes AWG 18-16 use only Cu lines Max. tightening torque 0.79 in-lbs

## Installation

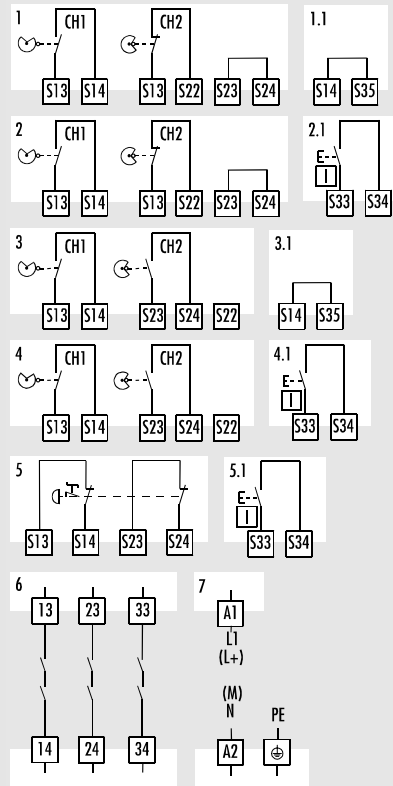

	Beachten Sie bei der Installation das Anschluss Schaltbild.	Please consult the connection diagram during installation.	Lors de l'installation, respecter le schéma des connexions.
1	<b>Schutztür</b> (geöffnet) antivalente ansteuerung, automatischer Start, Querschlusserkennung	<b>Safety door</b> (open) non-equivalent activation, automatic start, cross monitoring	<b>Porte de protection</b> (ouverte) commande d'amorçage non-équivalente, démarrage automatique, détection de courts-circuits
1.1	Brücke automatischer Start	Bridge automatic start	Pont du démarrage automatique
2	<b>Schutztür</b> (geöffnet) antivalente ansteuerung, manueller Start, Querschlusserkennung	<b>Safety door</b> (open) non-equivalent activation, manual start, cross monitoring	<b>Porte de protection</b> (ouverte) commande d'amorçage non-équivalente, démarrage manuel, détection de courts-circuits
2.1	Reset-Taster (S14/S34 bei AC-Gerät)	Reset button (S14/S34 on AC device)	Bouton-poussoir Reset (S14/S34 avec appareil AC)
3	<b>Schutztür</b> (geöffnet) äquivalente ansteuerung, automatischer Start, Querschlusserkennung (S22 unbeschaltet)	<b>Safety door</b> (open) equivalent activation, automatic start, cross monitoring (S22 disconnected)	<b>Porte de protection</b> (ouverte) commande d'amorçage équivalente, démarrage automatique, détection de courts-circuits (S22 pas recouvert)
3.1	Brücke automatischer Start	Bridge automatic start	Pont du démarrage automatique
4	<b>Schutztür</b> (geöffnet) äquivalente ansteuerung, manueller Start, Querschlusserkennung (S22 unbeschaltet)	<b>Safety door</b> (open) equivalent activation, manual start, cross monitoring (S22 disconnected)	<b>Porte de protection</b> (ouverte) commande d'amorçage équivalente, démarrage manuel, détection de courts-circuits (S22 pas recouvert)
4.1	Reset-Taster (S14/S34 bei AC-Gerät)	Reset button (S14/S34 on AC device)	Bouton-poussoir Reset (S14/S34 avec appareil AC)
5	<b>Not-Aus</b> zweikanalig, manueller Start, Querschlusserkennung	<b>Emergency stop</b> two-channel, manual start, cross monitoring	<b>Arrêt d'urgence</b> à deux canaux avec démarrage manuel, détection de courts-circuits
5.1	Reset-Taster (S14/S34 bei AC-Gerät)	Reset button (S14/S34 on AC device)	Bouton-poussoir Reset (S14/S34 avec appareil AC)
6	<b>Freigabestrompfade</b> 3 Schließer, zwangsgeführt	<b>Enabling current paths</b> 3 NO contacts, positively driven	<b>Contacts de sortie</b> 3 contacts de travail, à guidage forcé
7	<b>Versorgungsspannung</b> PE nur bei AC-Gerät	<b>Supply voltage</b> PE on AC device only	<b>Tension d'alimentation</b> PE uniquement pour les appareils AC

Anschlusschaltbild/ Connection Diagram / Schéma de connexions

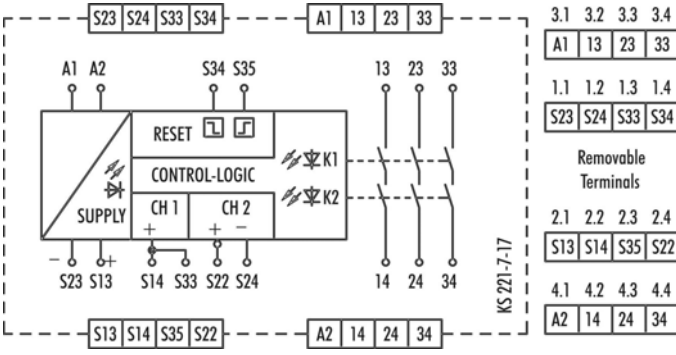

Montage, Assembly, Montage

	<p><b>1</b> Relais auf die Hutschiene einhängen.</p>	<p><b>1</b> Attach relay to DIN rail.</p>	<p><b>1</b> Posez le relais sur le rail DIN.</p>
	<p><b>2</b> Durch leichten Druck in Pfeilrichtung Relais auf die Hutschiene aufsnappen.</p>	<p><b>2</b> Press the relay carefully onto the DIN rail (in direction of arrow) until it locks into place.</p>	<p><b>2</b> Appuyez le relais légèrement contre le rail DIN (en direction de la flèche).</p>

Demontage, Disassembly, Démontage

	<p><b>3</b> Relais in Pfeilrichtung herunterdrücken.</p>	<p><b>3</b> Push relay down (in direction of arrow)</p>	<p><b>3</b> Appuyez sur le relais (en direction de la flèche).</p>
	<p><b>4</b> Im heruntergedrückten Zustand Relais in Pfeilrichtung aus der Verrastung lösen und von der Hutschiene nehmen.</p>	<p><b>4</b> Release relay and remove it from the DIN rail (see arrow)</p>	<p><b>4</b> Déverrouillez le relais et retirez-le du rail DIN (voir la flèche).</p>

Abmessungen / Dimension Diagram / Dimensions



Änderungen vorbehalten / Subject to changes / Sous réserve de modification

GE Security Industrial  
12345 SW Leveton Drive  
Tualatin, Oregon 97062  
United States

## Application Examples

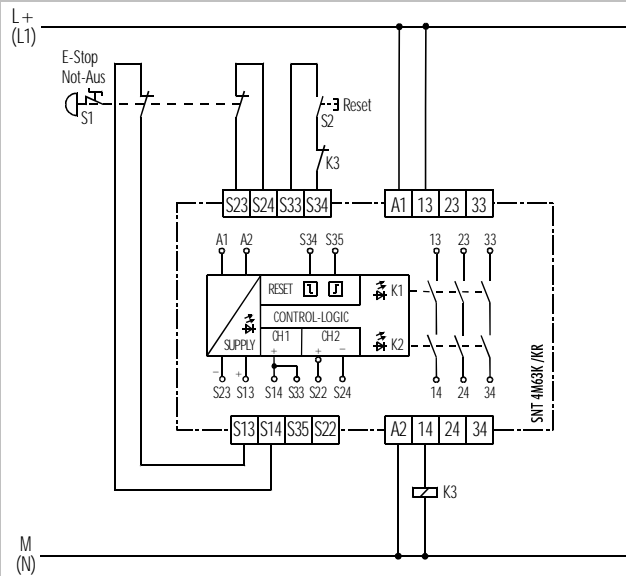

Dual channel Emergency Stop monitoring with two N.C. safety circuits, manual start, Reset-key monitoring and cross monitoring. In accordance up to safety category 4.

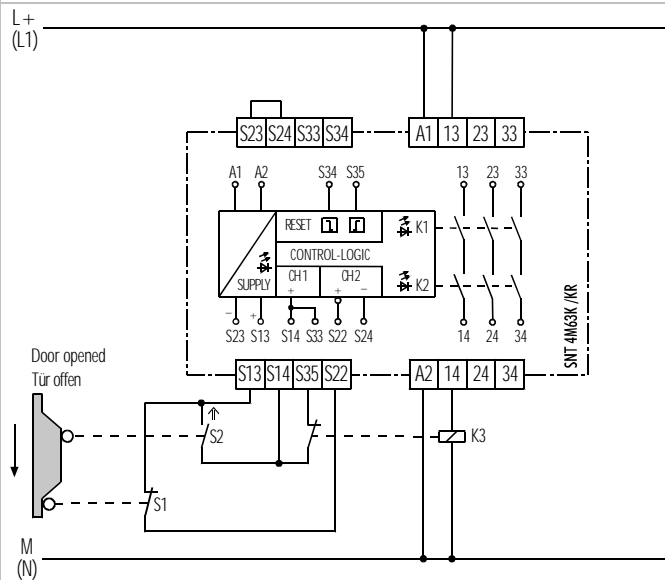

Dual channel safety gate switch monitoring with N.C./N.O. safety circuits, automatic start and cross monitoring. In accordance up to safety category 4.