

FRAME PREPARATION FOR REMOVABLE MULLION

1. Locate the top and bottom mounting brackets butted up to the inside face of the door and at the center of the door opening so that both doors will equally overlap the mullion. (Use the mounting brackets as templates to locate mounting holes.)

Note: The type of frame may require a shim to properly secure the top mounting bracket.

2. Cut the threshold for the bottom bracket for mounting directly to the finished floor.

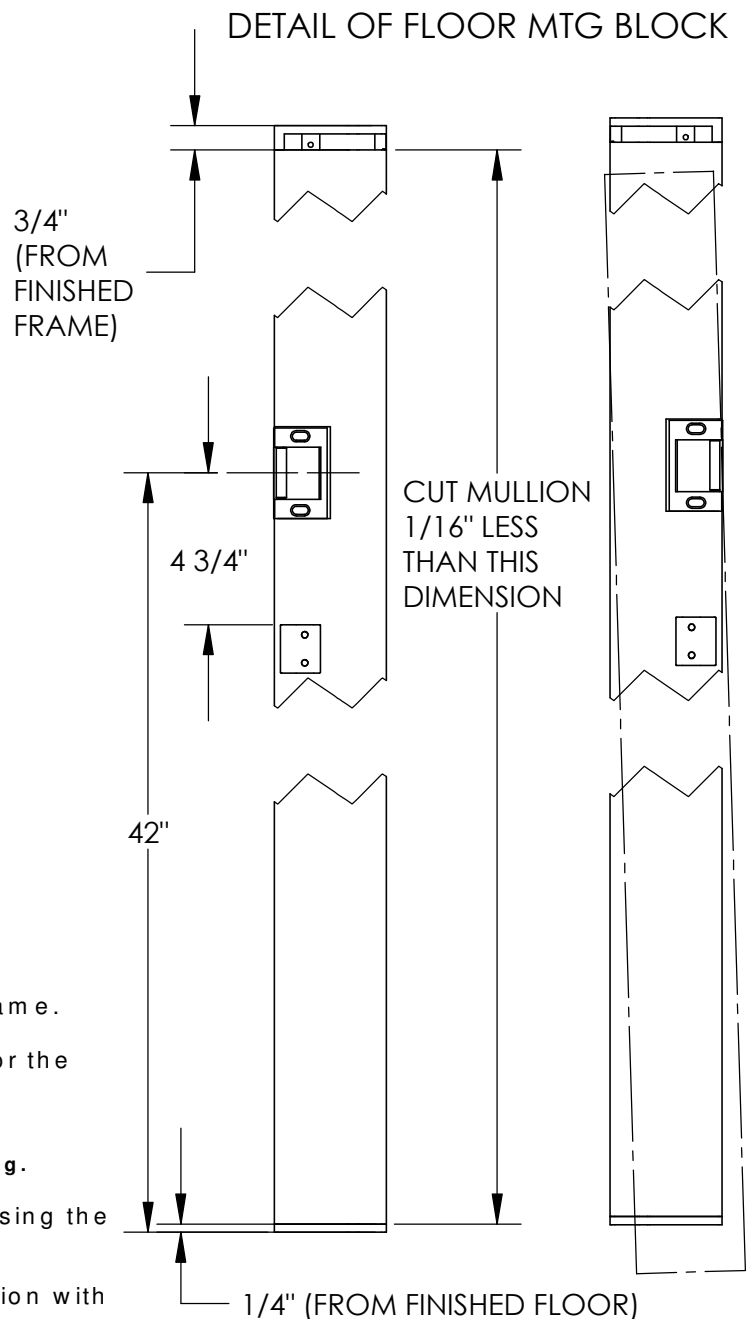
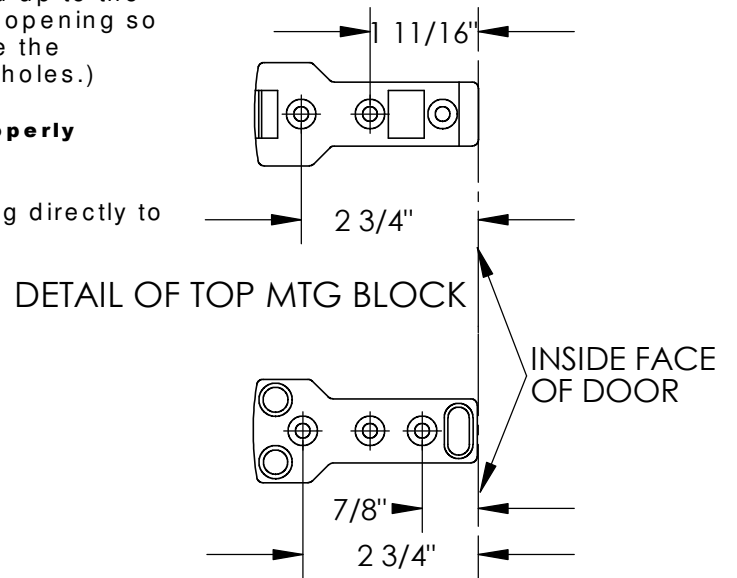
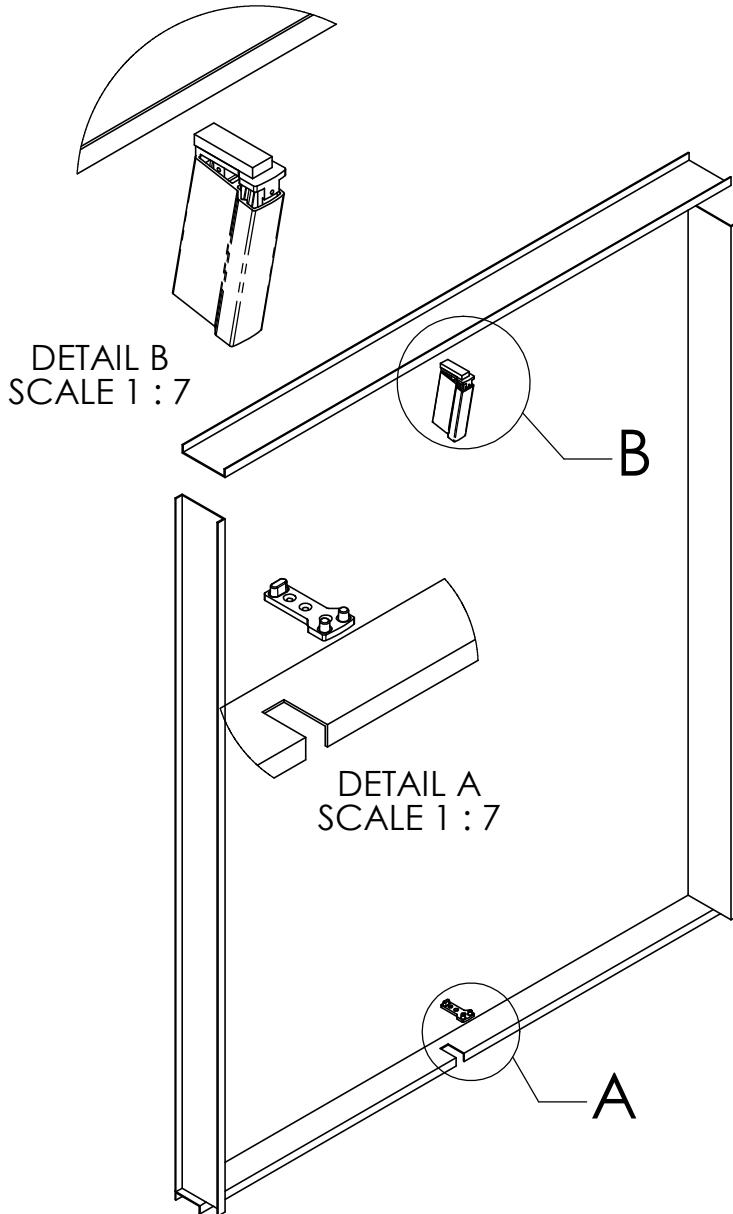

MULLION PREPARATION

1. Measure the opening from finished floor to top frame.
2. Subtract 1-1/16" from the above dimension (3/4" for the top bracket, 1/4" for bottom bracket and 1/16" for clearance) and cut Mullion to calculated length.

Typically cut mullion to 83-7/16" for a 84-1/2" frame opening.

3. Attach the two Mullion Portion of Security Clips using the pre-drilled holes.
4. Slide Mullion Cover Plate over the top of the mullion with the mounting holes closest to the top.