

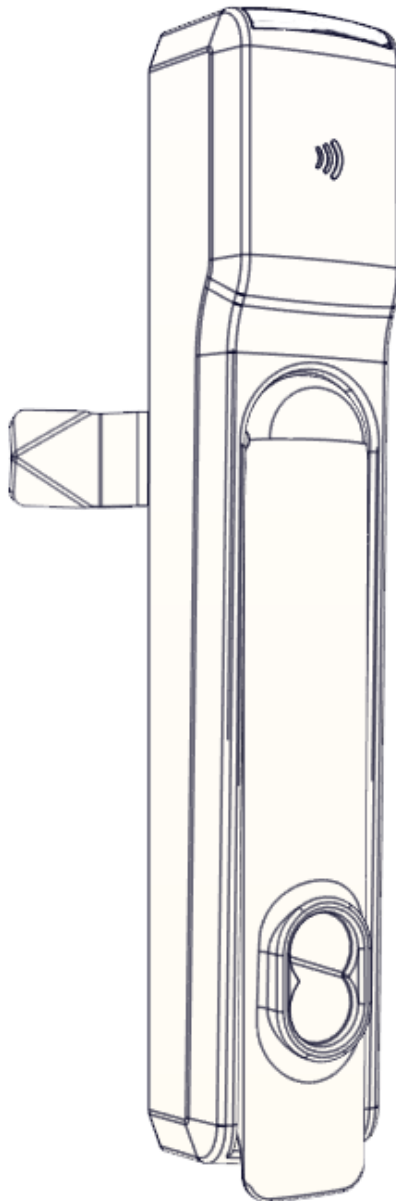

HES, Inc.
Phoenix, AZ
1.800.626.7590
www.hesinnovations.com

KS200-640 Server Cabinet Lock Series Installation Instructions



Package Contents

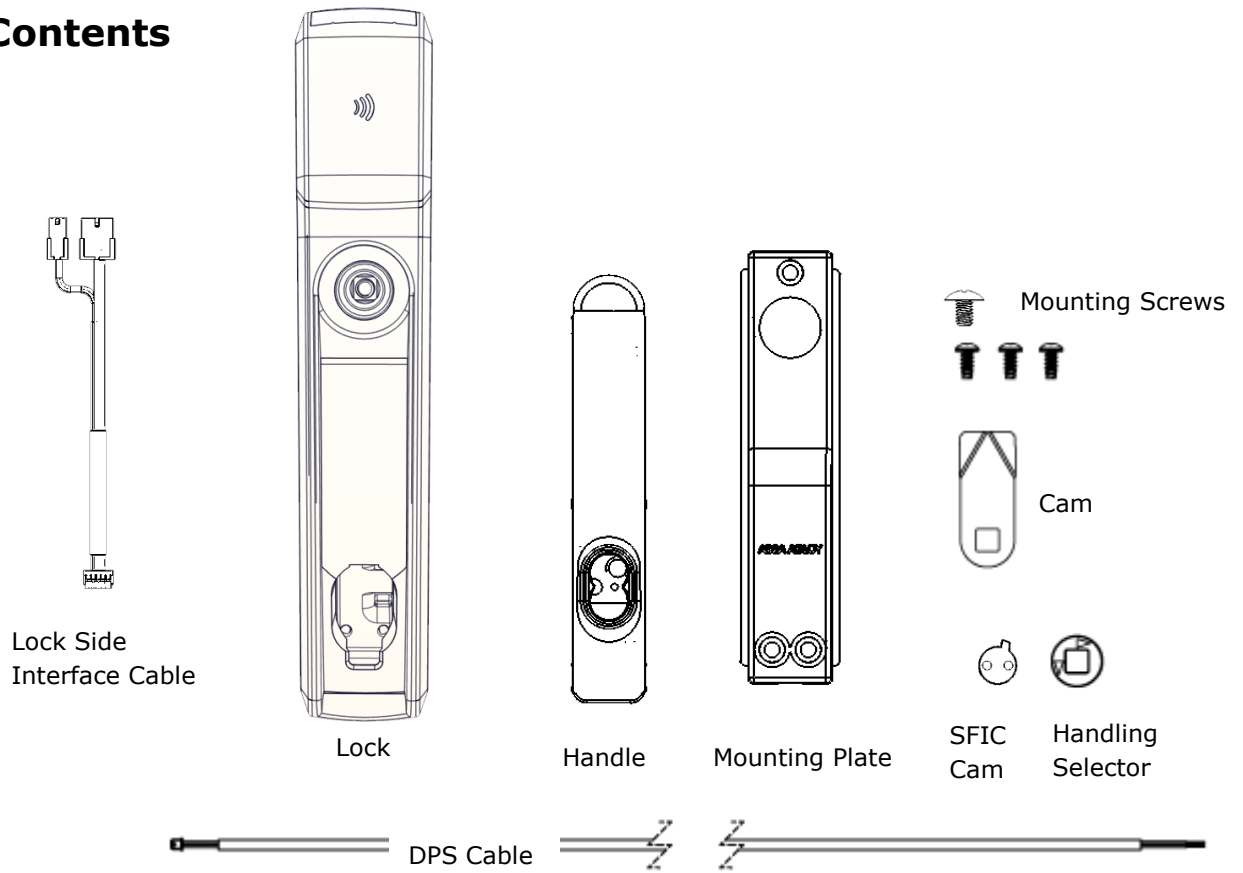

Recommended Tools

Approved RFID Credential
Phillips P2 driver
WT-2 Wiegand Test Box

Optional Additional Tools:
SFIC Core for key override or
SFIC Blank Plastic Core

Normally Open DPS Switches
System Side Interface Cable

Specifications

Voltage: 12–24 VDC $\pm 10\%$ (Power Supply not provided)

KS200-640 (Reader) Current Consumption:

12 VDC:	37 mA peak for Red and Green LED only
	470 mA peak for Red and Green LED and Motor Drive
24 VDC:	18 mA peak for Red and Green LED only
	245 mA peak for Red and Green LED and Motor Drive

Operating Temperature: -10C to 50C

Holding Force: 250 lbs

Connector Pin Wiring:

Molex 8-Pin Connector Pin	Wire Color	Description
1	Black	12 VDC Reader (-)
2	White	Wiegand Data (1)
3	N/A	N/A
4	N/A	N/A
5	Red	12 VDC Reader (+)
6	Green	Wiegand Data (0)
7	Blue	Red LED
8	Yellow	Green LED
Molex 4-Pin Connector Pin		
1	Violet	12/24 VDC / Lock (COM, -)
2	Pink	Tamper / DPS (NC, +)
3	Gray	12/24 VDC / Lock (COM, +)
4	Tan	Tamper / DPS (COMM, -)

LED Function: LED states are controlled and defined by the User's EAC. Enabling the red and green LEDs on the KS200 occurs via an active low (ground) signal.

Output Type: SIAAC-01-1996 Wiegand Output Compliant.

FCC Part 15 Compliant, Industry Canada Compliant, European Commission Compliant

BHMA: A156.3, A156.36, A156.25 Compliant

NOTE: Contact HID Global Technical Support at (866) 607-7339 for additional configuration cards to enable the credential capabilities of "iCLASS Elite" and "NFC over HCE."

Credentials Supported: 125 kHz Proximity or 13.56 MHz iCLASS, iCLASS Elite, iCLASS SEOS, iCLASS SE, ISO 15693 ICLASS, ISO 14443A Mifare, Mifare Plus, Desfire SE, Desfire EV1, and NFC over HCE.

System Overview

The KS200 is a radio-frequency identification (RFID) lock for server cabinet installation applications. The lock is capable of reading RFID credentials and providing that data to an electronic access control (EAC) system via Wiegand data signaling. The EAC determines whether user access should be granted or denied. When the EAC provides an active-high unlock signal to the lock in the access granted case, the KS200-640 drives a motor to complete the unlock/lock cycle. EAC indication of user access/denial is provided to the user by way of LED control inputs on the lock. Additional lock monitoring features (e.g., door position, tamper) are monitored within the lock and status provided to the EAC.

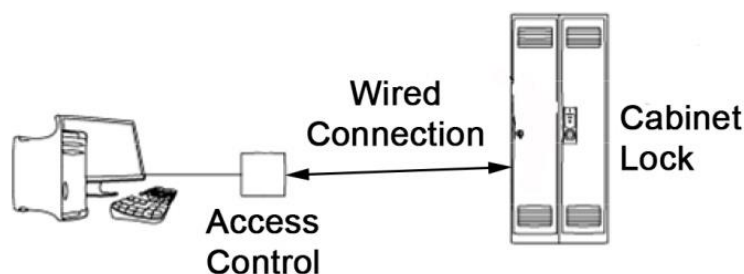

Installation

1. Installing an SFIC Core

NOTE 1: A key override (SFIC) provides a backup entry method in the rare case the KS200 or EAC is inactive (Recommended).

NOTE 2: The included SFIC cam has been tested with Medeco and Sargent 6- or 7-pin SFIC cores.

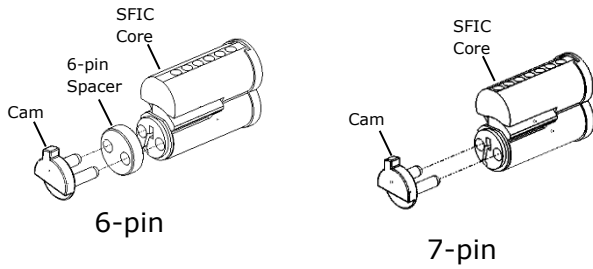

1. Insert Cam into SFIC
Use the included Spacer with 6-pin SFICs.

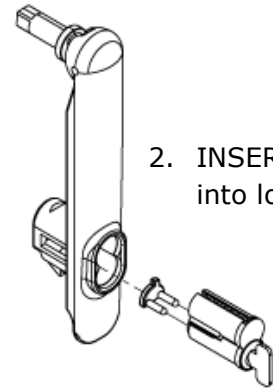

2. INSERT SFIC into lock

2. Preparing the Cabinet

1. LOCATE the 1" [25 mm] x 6" [150 mm] lock cutout on the door (some doors may require modification).
2. ENSURE power is available at the rack.
3. RE-USE the existing cam, if possible.

NOTE: One cam is supplied.

CAM	CAM LENGTH	CAM DEPTH
CAM 1	1-1/2" [38 mm]	15/16" [24 mm]

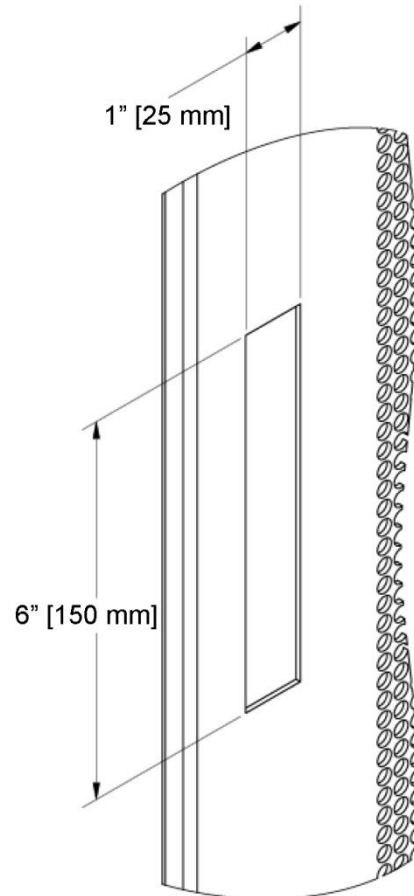
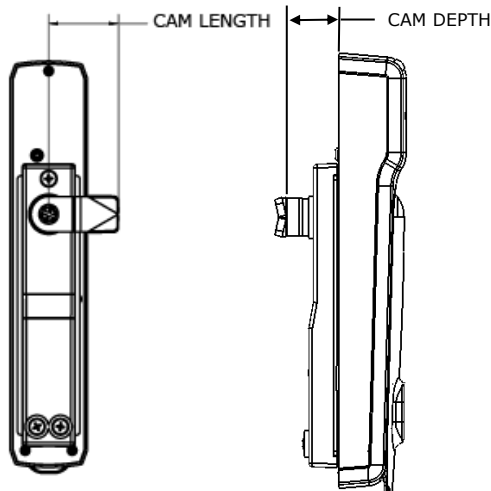

3. Installing the Lock

1. SLIDE lock into cutout.

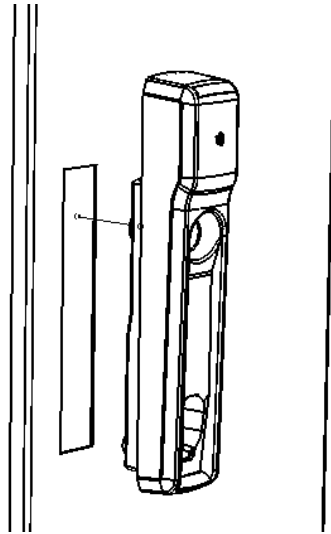

NOTE: (Optional) The DPS signal is closed when the handle is resting in its locked position. The DPS circuit can be extended to include normally open DPS switches arranged in a series to monitor additional doors and panels.

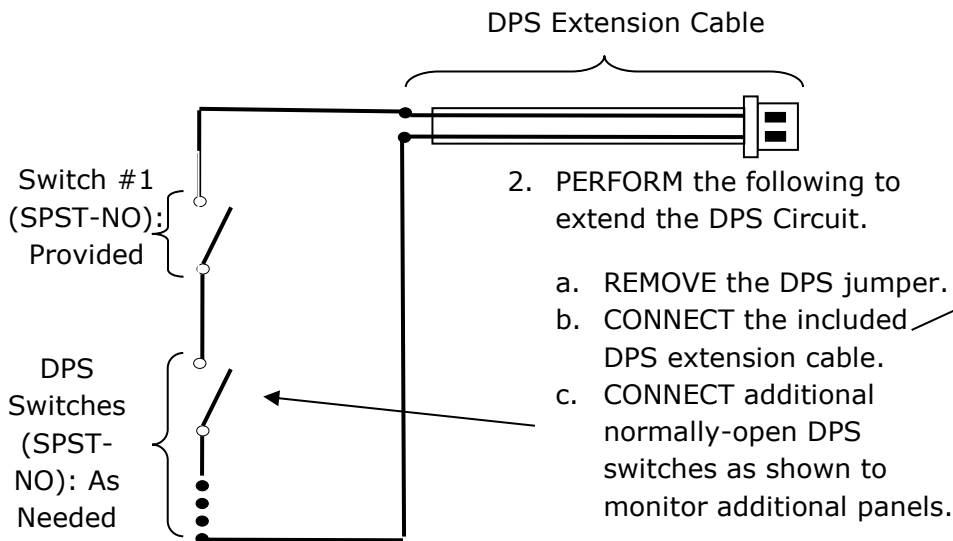

3. CONNECT the female, 10-position Hirose™ connector on the lock side interface cable to the KS200.
4. ENSURE the lock side interface cable will properly protrude from the bottom of the KS200 prior to attaching the rear bracket. ENSURE the wiring is not obstructing the mounting holes prior to securing the rear bracket.

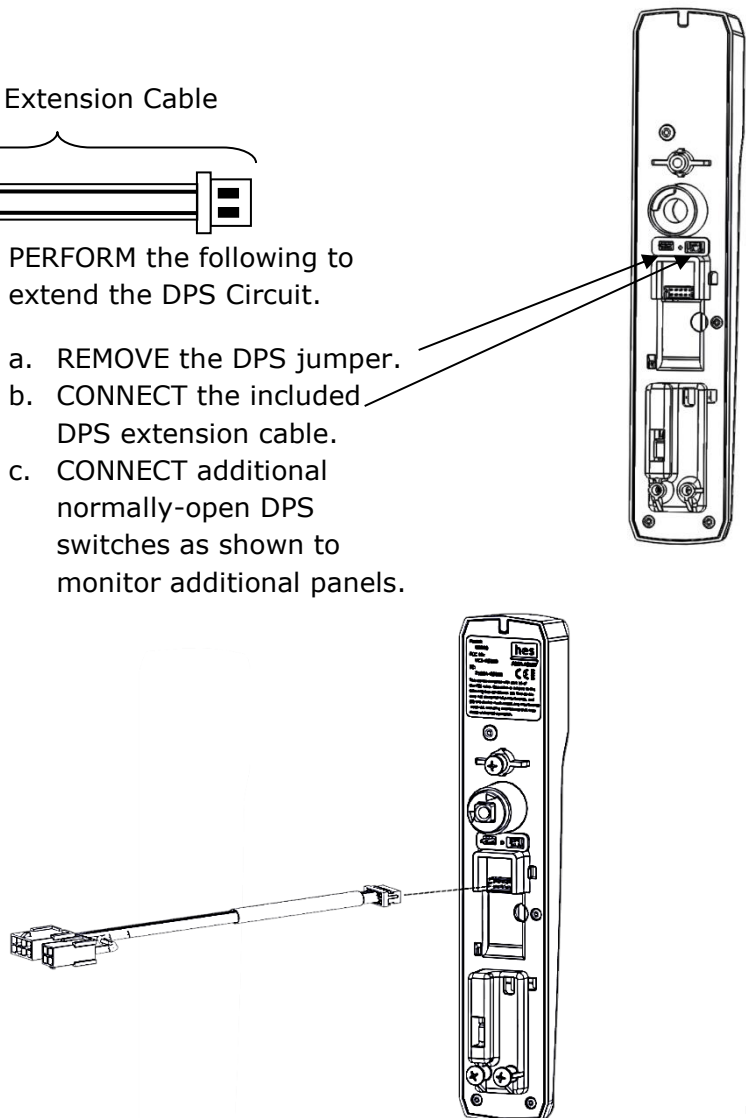

5. ATTACH rear bracket with screws.

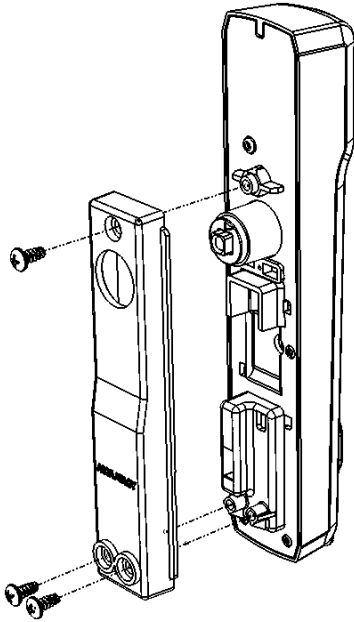

6. ENSURE that the lock is fully secured and flush to the mounting surface in order to depress tamper switch on back of device for correct operation.

NOTE: If the tamper switch is not fully depressed, the lock opens the Tamper/DPS+/- contact.

7. **IF** the tamper switch is not fully closed, **THEN REMOVE** the tamper contact, **AND ENSURE** the lock is closed.

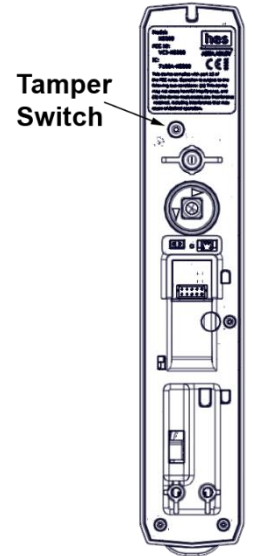

4. Installing the Handing Selector

CAUTION! Inserting/snapping the handle all the way in will lock the lever

1. INSERT handing selector into lock.

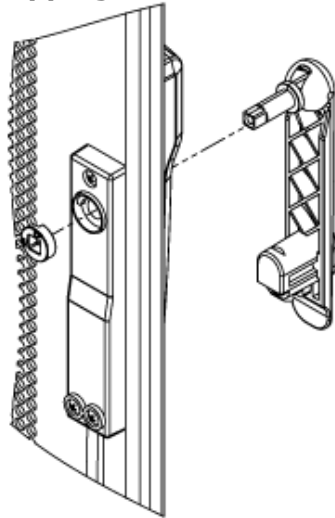

2. POSITION the arrows to point toward the door edge.

Door edge

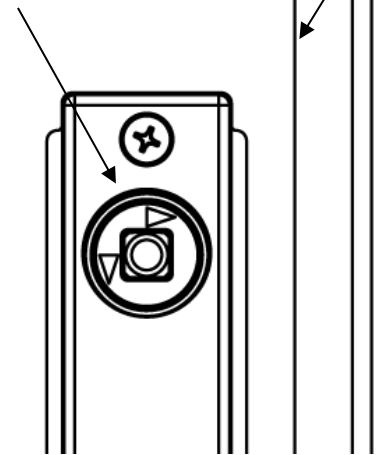

3. INSERT and SECURE cam with screw.

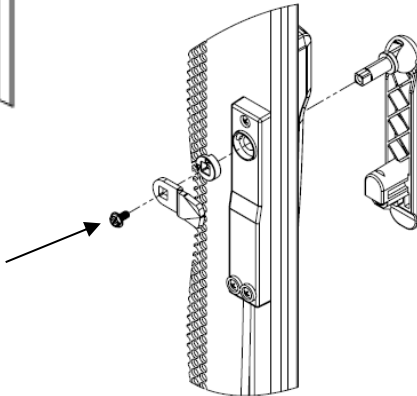



5. Attaching the Wiring

New 4-/8-Pin Molex

Integrated Wiegand: K/KS200 Cabinet Locks, ElectroLynx Wire Color/Function Assignments

Connector	8-Pin Molex Connector								4-Pin Molex Connector			
Pin/Wire Color	1 Black	2 White	3 N/A	4 N/A	5 Red	6 Green	7 Blue	8 Yellow	1 Violet	2 Pink	3 Gray	4 Tan
Function	12 VDC Reader	Wiegand Data	N/A	N/A	12 VDC Reader	Wiegand Data	LED		12/24 VDC/ Lock	Tamper/ DPS	12/24 VDC/ Lock	Tamper/ DPS
Setting	NEG	Data 1	N/A	N/A	POS	Data 0	RED	Green	COM, -	NC, +	COM, +	COM, -

Legacy 10-Pin Molex to 4-/8-Pin Molex

Integrated Wiegand: K/KS200 Cabinet Locks, ElectroLynx Wire Color/Function Assignments

Connector	8-Pin Molex Connector								4-Pin Molex Connector			
Pin/Wire Color	1 Black	2 White	3 N/A	4 N/A	5 Red	6 Green	7 Orange	8 Brown	1 Gray	2 Yellow	3 Violet	4 Blue
Function	12 VDC Reader	Wiegand Data	N/A	N/A	12 VDC Reader	Wiegand Data	LED		12/24 VDC/ Lock	Tamper/ DPS	12/24 VDC/ Lock	Tamper/ DPS
Setting	NEG	Data 1	N/A	N/A	POS	Data 0	RED	Green	COM, -	NC, +	COM, +	COM, -

- CONNECT the Lock Side Interface Cable to the lock.
- CONNECT the Lock Side Interface Cable to the optional System Side Interface Cable (see Connector and Cable Diagram).
- RUN the System Side Interface Cable, as required (see Server Cabinet Wiring Example).
- ATTACH the included 4-Pin and 8-Pin Molex Female Connectors to the bare wire side of the System Side Interface Cable.

NOTE: It is recommended that 10-conductor, 24 AWG, cable be used.

- ENSURE the following power cabling guidelines are followed:

Wire AWG	Supply Voltage	Allowed Cable Length (ft.)*
20 AWG	12	419
	24	3217
22 AWG	12	264
	24	2023
24 AWG	12	166
	24	1272

* Round trip loss. $V = 2 \times I \times R \times \text{xft}$ → $\text{xft} = V / (2 \times I \times R)$

Connector and Cable Diagram

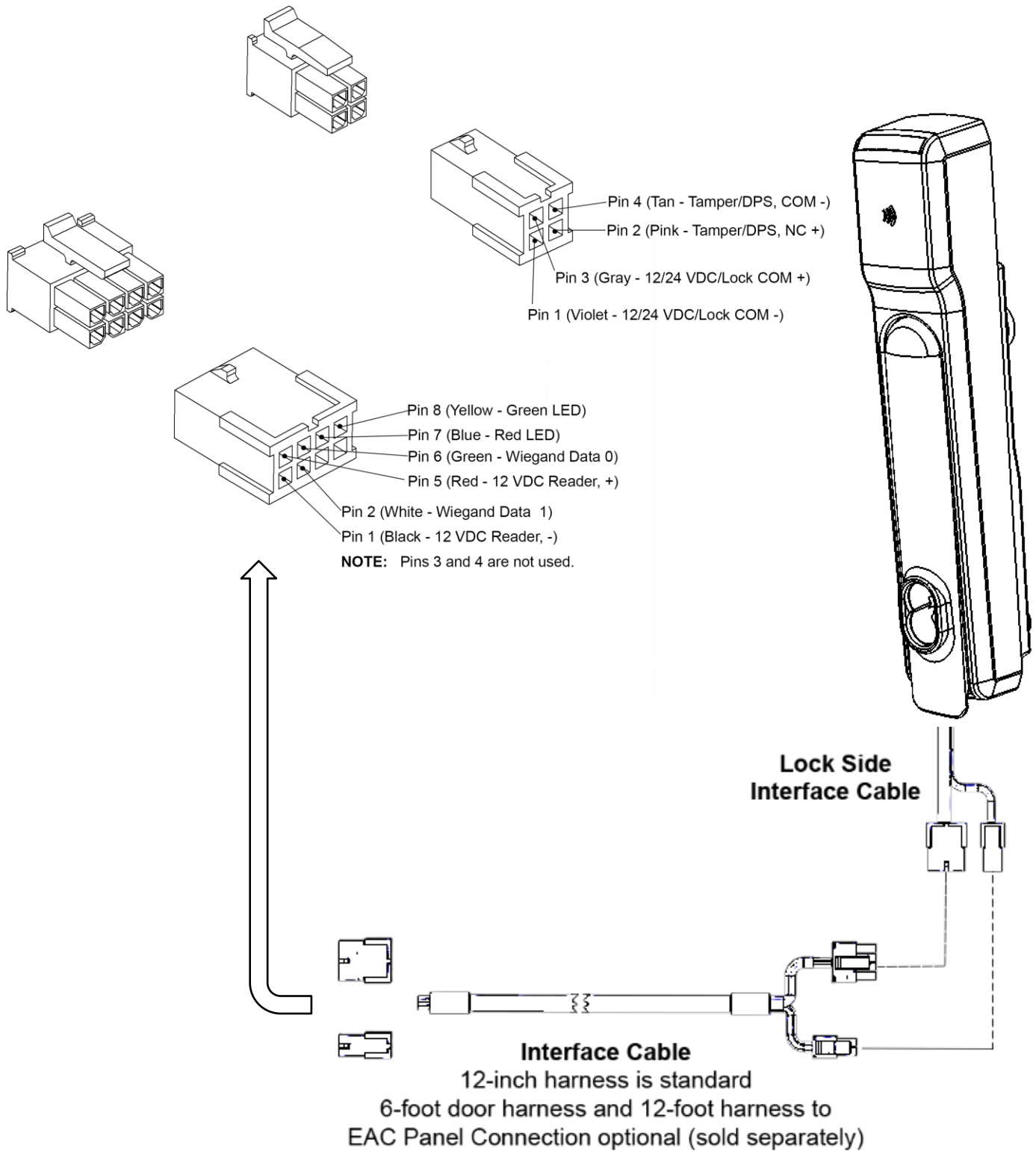

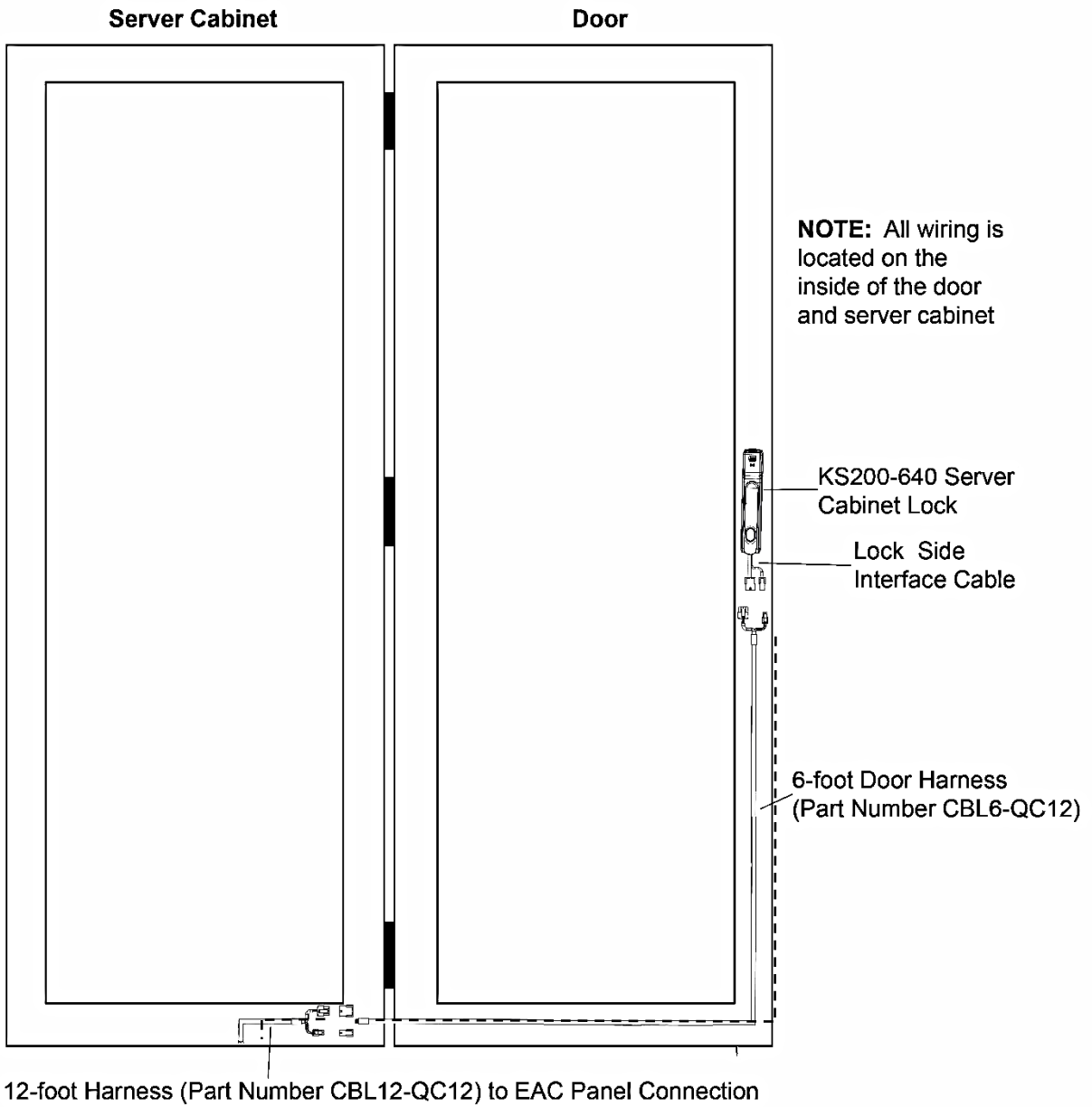

Server Cabinet Wiring Example

6. Testing the Lock with the Access Control System



1. TEST the lock with a known good credential to confirm it will open as desired when installed.
 - a. PRESENT a credential known to the EAC.
 - b. LIFT lever and TURN to open the cabinet.

This page intentionally left blank

FCC Statement

This device complies with part 15 of the FCC Rules. Operation is subject to the following two conditions:

- (1) This device may not cause harmful interference, and
- (2) this device must accept any interference received, including interference that may cause undesired operation.

IC Statement

This device complies with Industry Canada license-exempt RSS standards(s). Operation is subject to the following two conditions:

- (1) this device may not cause interference, and
- (2) this device must accept any interference, including interference that may cause undesired operation.

CE Statement

HES hereby declares that these proximity readers are in compliance with the essential requirements and other relevant provisions of Directive 1999/5/EC (http://ec.europa.eu/enterprise/sectors/rtte/files/guide2009-04-20_en.pdf).

Conformité aux normes FCC

Cet appareil est conforme à la Partie 15 des règlements de la FCC. Son fonctionnement est soumis aux deux conditions suivantes:

- (1) cet appareil ne peut causer d'interférences, et
- (2) cet appareil doit accepter toute interférence, y compris des interférences qui peuvent provoquer un fonctionnement indésirable du périphérique.

Conformité aux normes IC

Cet appareil est conforme avec Industrie Canada exempt de licence RSS standard(s). Son fonctionnement est soumis aux deux conditions suivantes:

- (3) cet appareil ne peut causer d'interférences, et
- (4) cet appareil doit accepter toute interférence, y compris des interférences qui peuvent provoquer un fonctionnement indésirable du périphérique.

Conformité aux normes CE

HES déclare par la présente que ces lecteurs à proximité sont conformes aux exigences essentielles et aux autres stipulations pertinentes de la Directive 1999/5/CE (http://ec.europa.eu/enterprise/sectors/rtte/files/guide2009-04-20_en.pdf).

For Technical Support, please call 1-800-626-7590

**For information on other HES cabinet lock solutions,
visit hesinnovations.com**