

# Stainless Steel Continuous Hinges



**Why Continuous?** Hager Companies heavy duty stainless steel continuous hinges are designed and engineered to evenly distribute door weight along the full length of the door, which eliminates localized stresses on the frame and reduces hinge failure. Hinges also help eliminate stress on closers, automatic operators, and panic and locking hardware by helping doors to stay properly aligned and offer proven reliability that can stand up to the daily rigors of high-traffic, high-impact areas.

## Table of Contents

Benefits and Features .....	2
Product Information .....	3
Fasteners .....	5
General Information .....	6
Electric Modifications .....	8
Concealed Leaf .....	10
Half Surface .....	15
Half Mortise .....	16
Full Surface .....	18

## BENEFITS AND FEATURES

### Heavy Duty, High-Quality Construction

Hager Companies stainless steel continuous hinges are 14-gauge type 304 stainless steel with lubricated nylon 6/6 bearings between each knuckle and stainless steel pin. They are corrosion resistant for swimming pool buildings, sewage and water treatment plants, and salt spray environments. These hinges are ideal for hospitals and other institutions where doors and frames are subjected to severe abuse.

### Superior Performance

Hager Companies stainless steel continuous hinges allow doors to stay properly aligned, eliminating stress on closers, automatic operators, panic, and locking hardware.

### Ease of Installation

Each hinge has symmetrical, non-handed hole patterns on standard sizes.

### Ideal for Retrofit

Hager Companies 790 Series stainless steel continuous hinges use the existing frame and cover the old butt hinge cut out locations.

### Energy Savings

These stainless steel continuous hinges provide a permanent weather barrier and reduce air infiltration by creating a seal from top to bottom of the door at the hinge stile.

### Fire-Rated

Hager Companies 790 Series stainless steel continuous hinges are stamped with an Underwriters Laboratories Inc. fire label. Refer to the individual catalog pages for UL listing information.



### Security

Hager Companies 790 Series stainless steel continuous hinges eliminate the gap between the door and frame, so doors cannot be pried open.

### Privacy

Hager Companies 790 Series stainless steel continuous hinges eliminate the gap or sightline at the hinge edge, offering privacy on hospital or toilet partition applications.

### Certification

Hager Companies 790 Series stainless steel continuous hinges are approved for ANSI A156.26 Grade 1 for 150-pound doors.

### Added Features

Moldings are supplied to cover exposed fastener heads on half-surface and full-surface models and are screwed in place. Models with hinge guards are supplied with adjustable screws allowing up to 1/4" (9 mm) width adjustment for doors to be squared accurately and easily in new installations and retrofits.

### Wide Throw

The width of the hinge leaf can be extended in order to clear the trim or wall conditions.



## PRODUCT INFORMATION

### DOOR AND FRAME PREPARATION

All 790 Series stainless steel continuous hinges are surface applied without cutouts. Cutout design and spacing coordination is thereby eliminated in both new construction and restoration work.

For models other than double edge guard models, reinforcement plates are not required in doors and frames except where the gauge is too thin or the material is too weak for the fasteners in relation to the door weight, or where abusive operation is anticipated. Consult Hager Companies Technical Service for more information.

Blank frames may be ordered with strike prep only or with a strike prep furnished on both sides with any model that will cover the frame rabbet. Doors should always be ordered without cutouts except for use in labeled openings in which the tested door assembly may have manufacturing restrictions. Continuous frame mortar guards are strongly recommended for masonry walls to avoid screw fastener interference with the mortar.

### Standard Finish

All 790 Series stainless steel continuous hinges are brushed to a satin finish (US32D).

### Special Finishes

Available in powder coat and offered in our stock colors listed in the price book. Lead time of up to 8-10 weeks may be required.

### Recommended Lengths

All 790 Series stainless steel continuous hinges are always installed flush with the top edge of the door. Recommended head clearance is 1/8" (3 mm). Order each hinge equal to the net door height. In the field, trimming should be done from the bottom of the hinge only.

### Custom Length Hinges

Hager Companies manufactures hinges over 119" (2023 mm) as two separate lengths. Hager will select hinge segment lengths from standard sizes for best economics in relation to length required. A special length should be specified from the net door height. To order, list the required hinge length dimension along with the "actual length" or "net door height."

### Custom Designs

For special designs and special applications, contact Hager Customer Service for more information. While such orders become subject to the change and cancellation policy, hole positioning will be optimized to ensure that the appearance and operation of the products are maintained.

### Custom Hole Pattern

Any hole pattern or shape other than Hager's standard hole pattern are available on all models. Contact Hager Customer Service for more information.

### No-Hole (Blank) Hinges

Holes omitted for special applications (i.e. welded hinge) is available on all models. Contact Hager Customer Service for more information.

## PRODUCT INFORMATION

### **Door Edge Guards**

Various models are supplied with a 14-gauge stainless steel channel that wraps the door edge and protects the door edges from damage by carts, beds, and equipment. Other models offer protection to the jamb with a wrap-around guard. Refer to individual catalog pages for additional information. Edge guards for the latch side edge of the door are available through our Trim & Auxiliary product line.

### **Dutch Door Hinges**

The frame leaf is furnished as a continuous leaf and the door leaf is cut to fit the dutch door heights specified. Upper and lower door leaves are prepped for extra screws. Handing, overall net door height, amount of clearance between the top and bottom doors, their individual heights and door and frame materials should be clearly specified.

### **Non-Rising Pin**

The pin is held securely in place and will not rise or fall from the knuckles during use. The top and bottom plugs are permanently secured to the hinge.

### **Raised Barrel**

For applications where the door is set back in the frame, the knuckle is offset to allow the hinge to clear the frame.

### **Replacement Moldings**

Brushed aluminum replacement moldings with molding clips and fasteners are available in stock lengths for trimming in the field. This option is available for 790-903, 790-904, 790-906, 790-909.

### **Sheared Leaf**

For narrow door thicknesses, leaf width can be trimmed. This option is available for 790-900, 790-903, 790-905, 790-909, 790-911, 790-915, 790-926.

### **Dust Free Bearings**

Provide a clean and quiet operation as they prevent metal on metal wearing.

### **Tamper Resistant Hospital Tip**

Concealed models, specifically 790-905 and 790-915, can be prepared with a tapered, 45° angled tip at the top of the hinge. These modified hinges are ideal for use in hospitals and correctional facilities to help provide a clean and safe environment.

## FASTENERS

Hager Companies 790 Series stainless steel continuous hinges are provided exclusively with carefully engineered and thoroughly tested fasteners. Each fastener is designed for ease of use as well as durability. Appropriate fasteners are furnished with each hinge, together with installation instructions for typical metal and wood doors hung on metal frames. The standard screw pack includes Dril-Kwik<sup>®</sup> self-drilling screws for metal doors and frames as well as wood screws for wood doors.

Special adjustment studs and screws are standard on all models with the double door edge protection lip. The special adjustment studs and screws allow correction of door fit problems up to 3/8" (9 mm). Sex bolts are optional and must be requested at time of order. If special fasteners are required, customers must supply them except upon prior agreement. Please consult Hager Technical Service for alternate fastener recommendations.

### Optional Sex Bolts

On all applicable full-surface and half-surface mounted hinge models, sex bolts can be ordered. Sex bolts are intentionally designed shorter than the door thickness to ensure proper clamping action of 1-3/4" (44 mm) doors of slightly varying thickness.

### Security Fasteners

These fasteners improve building security and reduce hinge tampering. Security Torx are available in place of standard fasteners upon request.

### Security Studs

These stainless steel security studs are mounted through the frame leaf into the door frame. Security studs are available in place of standard fasteners upon request.

### Fastener Installation

Fasteners for both metal and wood applications are supplied standard with each hinge. The Dril-Kwik<sup>®</sup> self-drilling screw is used in metal door and frame applications and has an undercut head and a machine thread on the screw shank. The type AB wood screw is supplied for wood door and frame applications.

The Dril-Kwik<sup>®</sup> self-drilling screw's drill point allows it to be placed without pre-drilled holes when installed in a hollow metal frame less than 1/8" (3 mm) thick. It forms its own threads as it is drilled into the frame.

Mortar Guards, made of either styrofoam or wood, are recommended for new construction, eliminating the use of masonry bits. For existing grout-filled frames, pre-drilling is required before installation of the Dril-Kwik<sup>®</sup> self-drilling screws. Here, the screw acts as a machine screw since drilling has already taken place. Center-punching is recommended on both hollow metal and grout-filled frames to ensure that the screw seats properly in the hinge leaf. Stainless steel frames require pre-drilling.

In all cases, care should be taken to ensure that no drill chips build up behind the hinge. It is best to pre-mark the holes and pre-drill with the hinge removed or clamp the hinge very tightly against the door or frame when using the self-drilling screws.

When installing the self-drilling type screw, make certain that the installer is familiar with the proper use and torque settings of a screw gun. Proper center-punching is extremely important with self-drilling screws. If center-punching is omitted or incorrectly done, the screw will "walk" in the same way as a drill bit, resulting in cocked screw heads and improperly closing hinges.

## GENERAL INFORMATION - DOOR AND FRAME DIMENSIONING

### Models 790-900, 790-911, 790-915

Designed primarily for work involving new doors and frames.  
Clearance required as follows:

#### Single Doors (Square and Beveled Edged)

A. Hinge thickness	7/32"	5.6 mm
B. Additional allowance for frame irregularities	1/32"	0.8 mm
C. Lockside clearance for single door	1/8"	3.2 mm
Total	3/8"	9.5 mm

#### Pairs of Doors (Square and Beveled Edged)

A. Hinge thickness	7/32"	5.6 mm
B. Additional allowance for frame irregularities	1/32"	0.8 mm
C. Clearance between doors (recommended)*	3/16"	4.8 mm
D. Second hinge thickness	7/32"	5.6 mm
E. Second allowance for frame irregularities	1/32"	0.8 mm
Total	11/16"	17.5 mm

#### Notes:

- Some minimal clearance may be required for paint and/or weatherstripping.
- For doors that are pre-beveled 1/8" (3.2 mm)-in-2" (51 mm) on the hinge edge, add 1/32" (0.8 mm) per door to the TOTAL clearance shown (Model 790-900 only). For Models 790-911 and 790-915, the hinge edge of the door should not be beveled.

### Models 790-905, 790-926

Designed primarily for work involving new doors and frames.  
Clearance required as follows:

#### Single Doors (Square and Beveled Edged)

A. Hinge thickness	9/32"	7.1 mm
B. Additional allowance for frame irregularities	1/32"	0.8 mm
C. Lockside clearance for single door	1/8"	3.2 mm
Total	7/16"	11.1 mm

#### Pairs of Doors (Square and Beveled Edged)

A. Hinge thickness	9/32"	7.1 mm
B. Additional allowance for frame irregularities	1/32"	0.8 mm
C. Clearance between doors (recommended)*	3/16"	4.8 mm
D. Second hinge thickness	9/32"	7.1 mm
E. Second allowance for frame irregularities	1/32"	0.8 mm
Total	13/16"	20.6 mm

#### Notes:

- Some minimal clearance may be required for paint and/or weatherstripping.
  - Not recommended for use on doors/panels that have a beveled edge on the hinge side.
- \*For fire rated doors, please refer to door manufacturer's requirement for edge to edge clearance to maintain compliance with NFPA requirements.

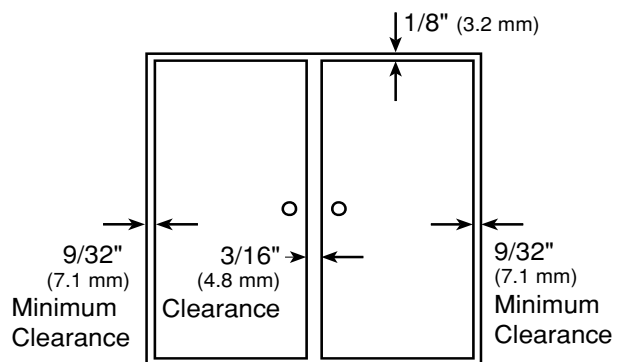
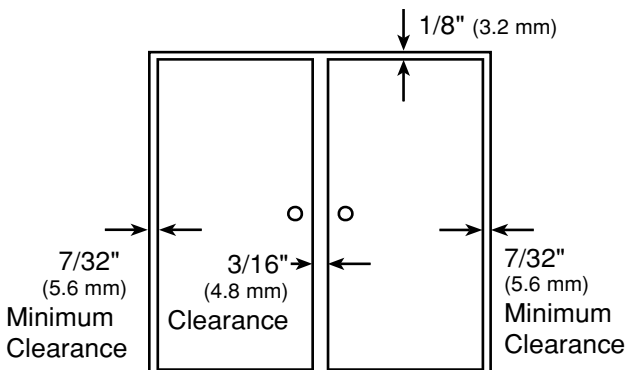
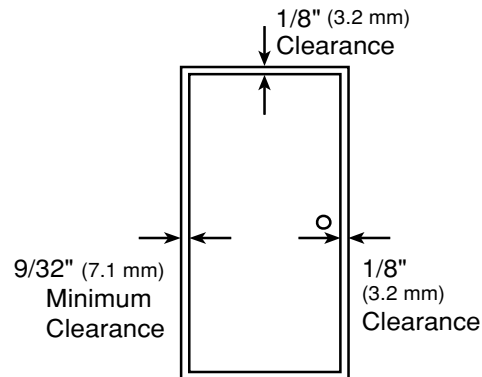
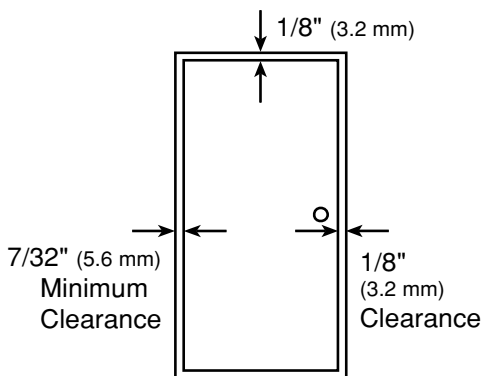



## GENERAL INFORMATION - DOOR AND FRAME DIMENSIONING

### Models 790-903, 790-904, 790-906, 790-909

Designed primarily for work involving new doors and frames.  
Clearance required as follows:

#### Single Doors (Square and Beveled Edged)

A. Hinge thickness	1/8"	3.2 mm
B. Additional allowance for frame irregularities	1/32"	0.8 mm
C. Lockside clearance for single door	1/8"	3.2 mm
Total	9/32"	7.2 mm

#### Pairs of Doors (Square and Beveled Edged)

A. Hinge thickness	1/8"	3.2 mm
B. Additional allowance for frame irregularities	1/32"	0.8 mm
C. Clearance between doors (recommended)*	3/16"	4.8 mm
D. Second hinge thickness	1/8"	3.2 mm
E. Second allowance for frame irregularities	1/32"	0.8 mm
Total	1/2"	12.7 mm

#### Notes for 790-904 only:

- Some minimal clearance may be required for paint and/or weatherstripping.
- For doors that are pre-beveled 1/8" (3.2 mm)-in-2" (51 mm) on the hinge edge, add 1/32" (0.8 mm) per door to the TOTAL clearance shown.

#### Notes for 790-906 only:

- The hinge edge of the door should not be beveled.
- \*For fire-rated doors, please refer to door manufacturer's requirement for edge to edge clearance to maintain compliance with NFPA requirements.

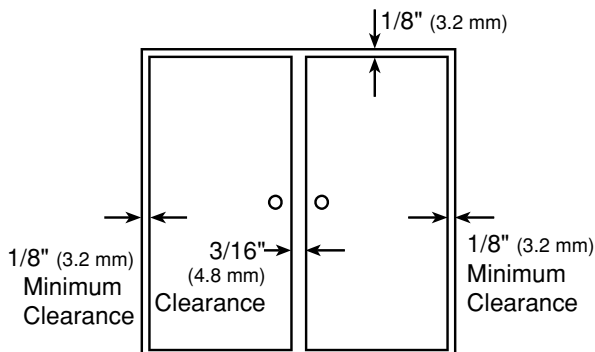
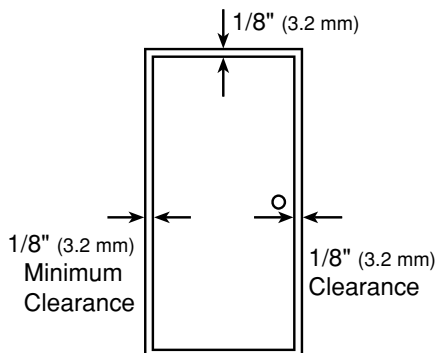

## ELECTRIC MODIFICATIONS

\* For ease of ordering, Hager has established standard locations for power transfer cutouts. All standard location dimensions are referenced from the top edge of the door to the centerline of the power transfer cutout. Please specify handing.

	79"	83"	85"	95"	119"
Opening	80"	84"	86"	96"	120"
Door Height	79-1/8"	83-1/8"	85-1/8"	95-1/8"	119-1/8"
Hinge Length	79-3/16"	83-1/8"	85-1/8"	95"	118-3/4"
ETW	41-1/2"	43-1/2"	45-1/2"	55-3/8"	79-1/8"
EPT	24-1/2"	28-7/16"	30-7/16"	40-1/2"	64-7/16"
E1S	41-1/2"	43-1/2"	45-1/2"	55-3/8"	79-1/8"

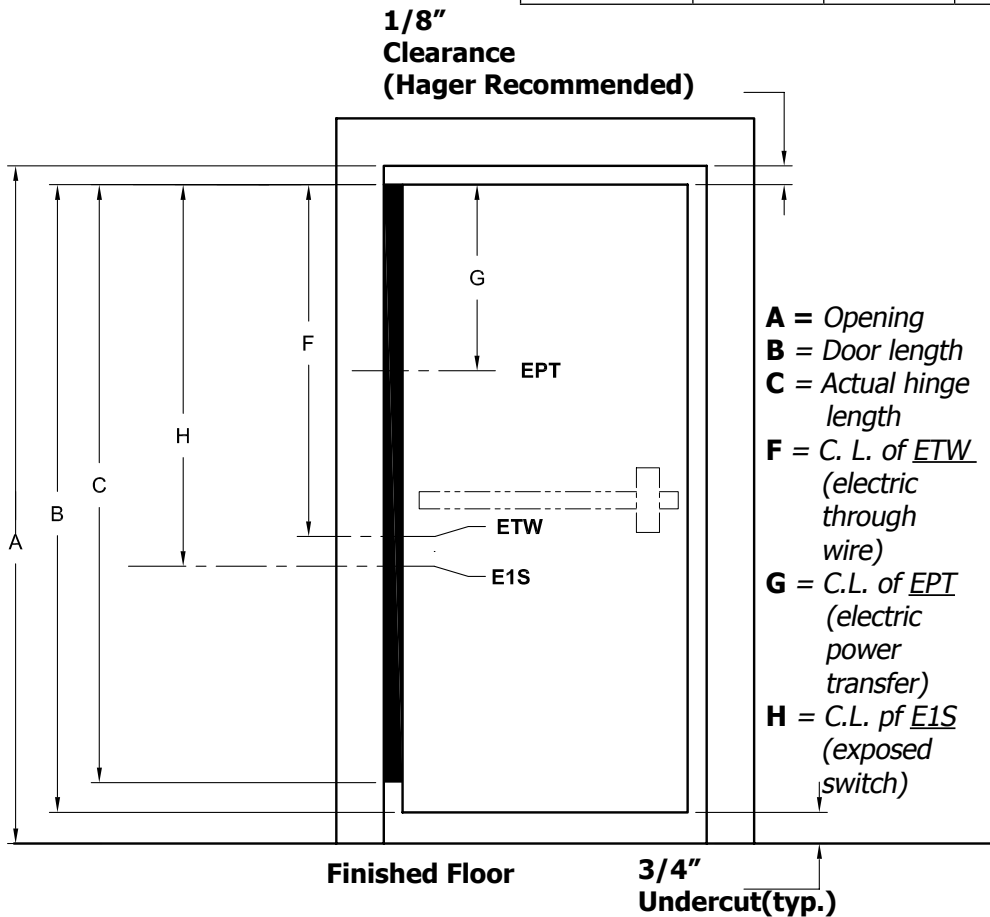

### Concealed Electric Through-Wire:

- Transfers power discreetly from building to door hardware
- Four, eight, or ten 24-gauge wires with 12" wire leads
- To order, use symbol "ETW" plus the number of wires required, as a suffix. Example: 790-900 HD 85" US32D ETW - 4
- Specify handing and dimension from top of hinge to centerline of electric through-wire location. Please note the clearance from top of hinge to underside of header, typically 1/16" to 1/8" (1.6 mm to 3.2 mm).
- Modification available on 790-900 and 790-915

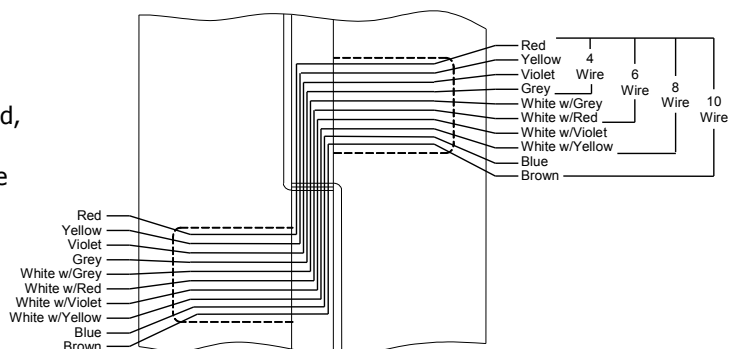





## ELECTRIC MODIFICATIONS

### Von Duprin EPT2 or EPT10 Electric Power Transfer Preparation

- Hinge leaf cutout to accommodate power transfer device
- Specify handing and dimension from top of hinge to centerline of power transfer cutout location. Please note the clearance from top of hinge to underside of header, typically 1/16" to 1/8" (1.6 mm to 3.2 mm).
- Modification available on models 790-900, 790-903, 790-904, and 790-915



### Exposed Electric Switches:

- Miniature push button switch is incorporated in the hinge frame leaf to monitor position of the door.
- Includes three 12" wire leads.
- To order, use symbol "E1S" as a suffix.  
Example: 790-900 85" US32D E1S
- Each monitoring hinge only needs one E1S switch.
- Specify handing and dimension from top of hinge to centerline of electric through-wire location. Please note the clearance from top of hinge to underside of header, typically 1/16" to 1/8" (1.6 mm to 3.2 mm).
- Templates regarding location of contact switch available upon request.
- Modification available on models 790-900 and 790-915.

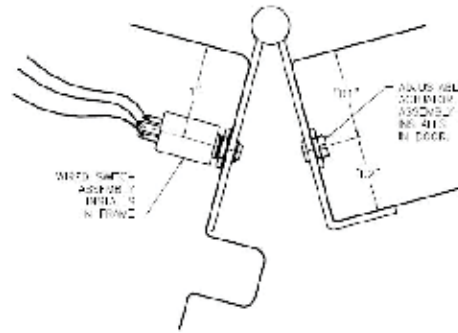

### Quick Connect:

Available for electric through wire option.



### Mortar Box - 430

- Serves as a mortar shield.
- Overall dimensions are 9" (229 mm) length with tabs, 7" (178 mm) (inside), 1-3/4" x 1-3/4" (45 mm x 45 mm) inside dimension.
- Galvanized steel 0.040" (1 mm).
- Top and bottom knockouts for standard conduit fittings.



## CONCEALED LEAF - 790-900 - DOOR OF ANY MATERIAL

### SPECIFICATIONS

Material:	14-gauge 304 stainless steel
Finish:	US32D Satin
Clearance:	7/32" (5.6 mm) hinge side plus standard lockside clearance
Fasteners:	<ul style="list-style-type: none"> <li>• #10-24 x 5/8" S/S Dril-Kwik® (metal frame/door)</li> <li>• #10-16 x 1-1/4" S/S Type AB (wood door)</li> </ul>
Length Options:	Standard and custom lengths available
Door/Frame Reinforcements:	<ul style="list-style-type: none"> <li>• Wood – None required up to 200 lbs.</li> <li>• Metal – Recommended 16-gauge channel for heavier weight</li> <li>• For metal doors, a 1/8" (3.2 mm) thick reinforcement plate is recommended along the hinge edge for proper thread engagement of the adjustment studs</li> </ul>
Fire Rating:	Up to 3 hour metal and 90 minute wood composite

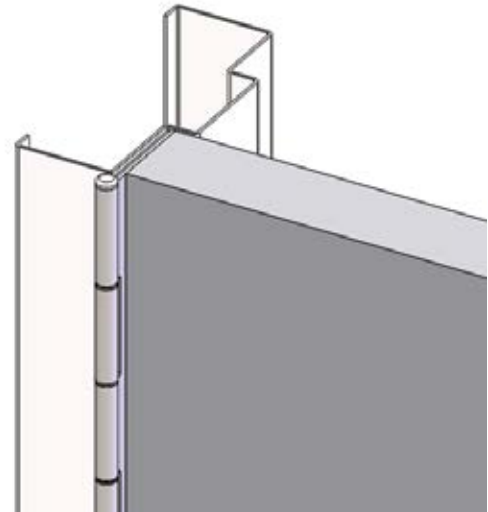

### FEATURES

- For doors 1-3/4" (44 mm) thick and up to 300 pounds
- 1/4" (6.3 mm) diameter stainless steel pin
- Dual 6/6 nylon bearings between each knuckle
- May be used with beveled or square edge doors
- 1/8" (3.2 mm) inset

Length (inches)	79"	83"	85"	95"	119"
Length (mm)	2007	2108	2159	2413	3023
Door Screws	19	21	21	23	27
Jamb Screws	19	21	21	23	27

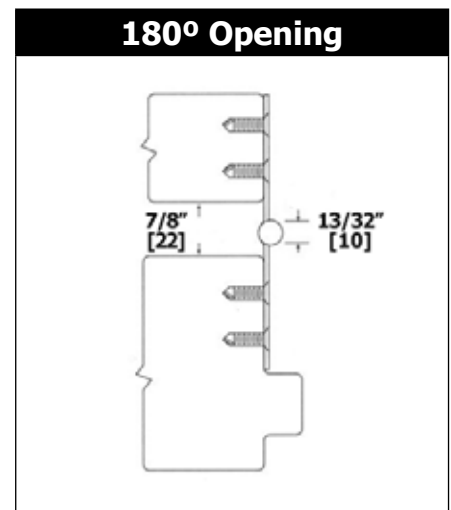
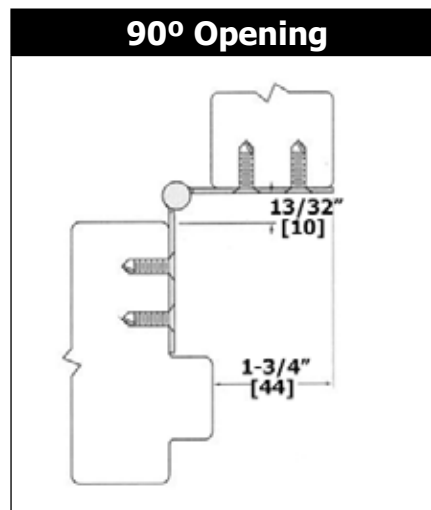
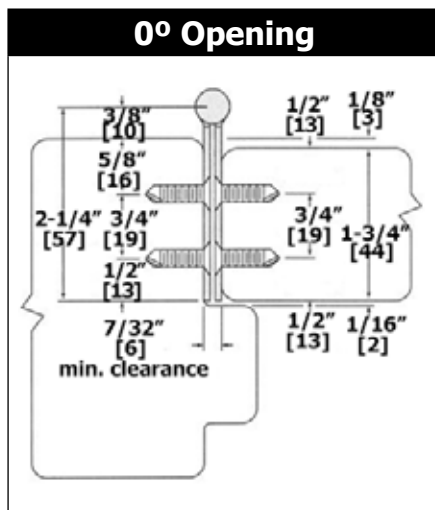



## CONCEALED LEAF - 790-905 - DOOR OF ANY MATERIAL

### SPECIFICATIONS

Material:	14-gauge 304 stainless steel
Finish:	US32D Satin
Clearance:	9/32" (7.1 mm) minimum hinge side plus standard lockside clearance
Fasteners:	<ul style="list-style-type: none"> <li>• #10-24 x 5/8" S/S Dril-Kwik® (metal frame)</li> <li>• #1/4-32 x 3/4" S/S machine screw (used with adjustment stud)</li> <li>• #7/16-20 x 1-3/8" S/S adjustment stud (metal/wood door)</li> </ul>
Length Options:	Standard and custom lengths available
Door/Frame Reinforcements:	<ul style="list-style-type: none"> <li>• Wood – None required up to 200 lbs.</li> <li>• Metal – Recommended 16-gauge channel for heavier weight</li> <li>• For metal doors, a 1/8" (3.2 mm) thick reinforcement plate is recommended along the hinge edge for proper thread engagement of the adjustment studs</li> </ul>
Fire Rating:	Up to 3 hour metal and 90 minute wood composite

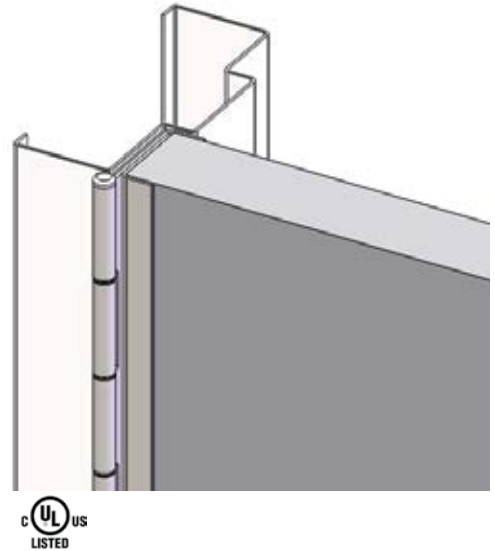

### FEATURES

- For doors 1-3/4" (44 mm) thick and up to 300 pounds
- 1/4" (6.3 mm) diameter stainless steel pin
- Dual 6/6 nylon bearings between each knuckle
- Door edge protection lip (both faces of door)
- Not recommended for doors with a beveled edge on the hinge side
- 1/16" (1.6 mm) inset

Length (inches)	79"	83"	85"	95"	119"
Length (mm)	2007	2108	2159	2413	3023
Door Screws	19	21	21	23	27
Jamb Screws	19	21	21	23	27

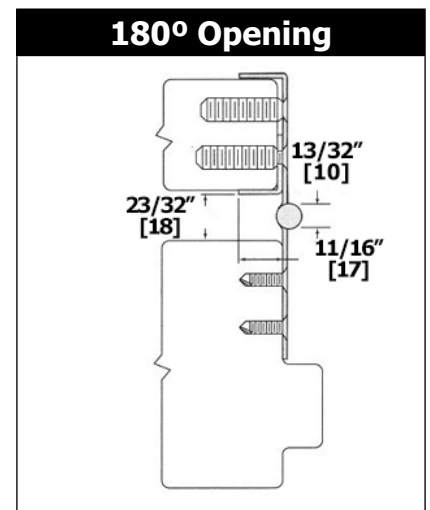
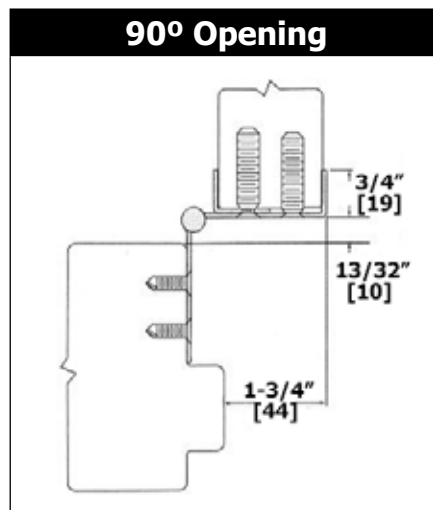
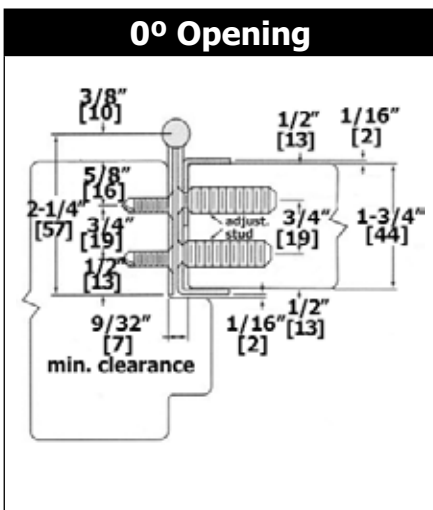

## CONCEALED LEAF - 790-911 - SWING CLEAR - DOOR OF ANY MATERIAL

### SPECIFICATIONS

Material:	14-gauge 304 stainless steel
Finish:	US32D Satin
Clearance:	7/32" (5.6 mm) hinge side plus standard lockside clearance
Fasteners:	<ul style="list-style-type: none"> <li>• #10-24 x 5/8" S/S Dril-Kwik® (metal frame/door)</li> <li>• #10-16 x 1-1/4" S/S Type AB (wood door)</li> </ul>
Length Options:	Standard and custom lengths available
Door/Frame Reinforcements:	<ul style="list-style-type: none"> <li>• Wood – None required up to 200 lbs.</li> <li>• Metal – Recommended 16-gauge channel for heavier weight</li> <li>• For metal doors, a 1/8" (3.2 mm) thick reinforcement plate is recommended along the hinge edge for proper thread engagement of the adjustment studs</li> </ul>
Fire Rating:	Up to 3 hour metal and 90 minute wood composite

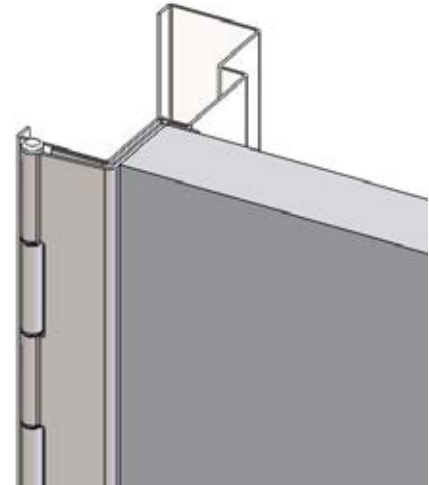

### FEATURES

- For doors 1-3/4" (44 mm) thick and up to 300 pounds
- 1/4" (6.3 mm) diameter stainless steel pin
- Dual 6/6 nylon bearings between each knuckle
- Wrap-around frame leaf design for easy installation and protection
- Door edge protection lip (stop side only)
- Useful for ADA upgrade work
- Not for use on doors with a beveled edge on the hinge side

Length (inches)	79"	83"	85"	95"	119"
Length (mm)	2007	2108	2159	2413	3023
Door Screws	19	21	21	23	27
Jamb Screws	19	21	21	23	27

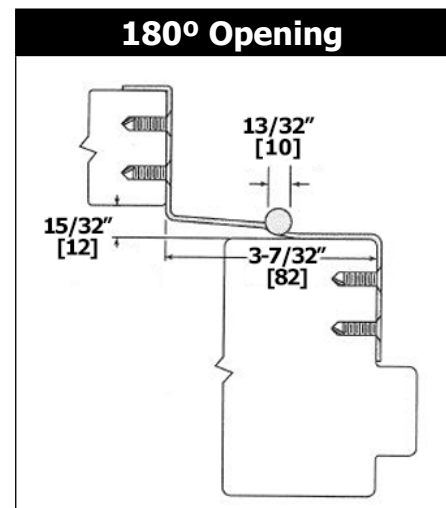
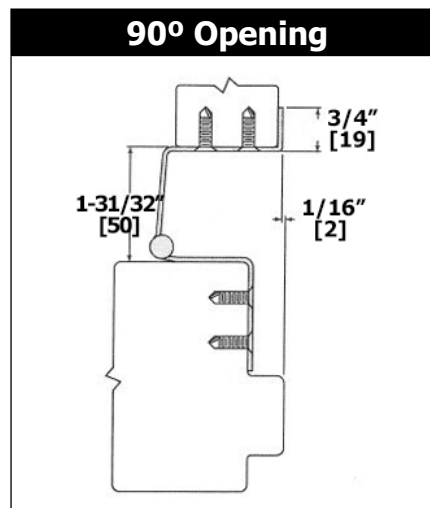
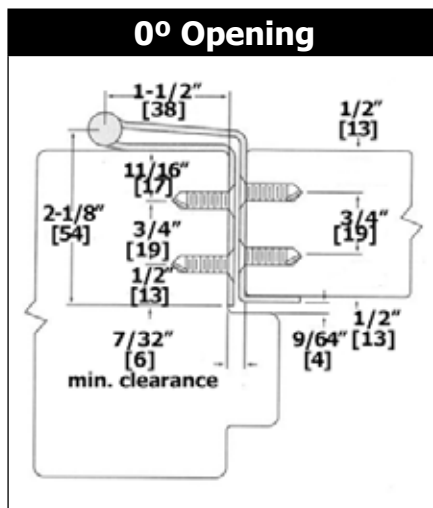



## CONCEALED LEAF - 790-915 - DOOR OF ANY MATERIAL

### SPECIFICATIONS

Material:	14-gauge 304 stainless steel
Finish:	US32D Satin
Clearance:	7/32" (5.6 mm) plus standard lockside clearance
Fasteners:	<ul style="list-style-type: none"> <li>• #10-24 x 5/8" S/S Dril-Kwik® (metal frame/door)</li> <li>• #7/16-20 x 1-1/4" S/S Type AB (wood door)</li> </ul>
Length Options:	Standard and custom lengths available
Door/Frame Reinforcements:	<ul style="list-style-type: none"> <li>• Wood – None required up to 200 lbs.</li> <li>• Metal – Recommended 16-gauge channel for heavier weight</li> <li>• For metal doors, a 1/8" (3.2 mm) thick reinforcement plate is recommended along the hinge edge for proper thread engagement of the adjustment studs</li> </ul>
Fire Rating:	Up to 3 hour metal and 90 minute wood composite

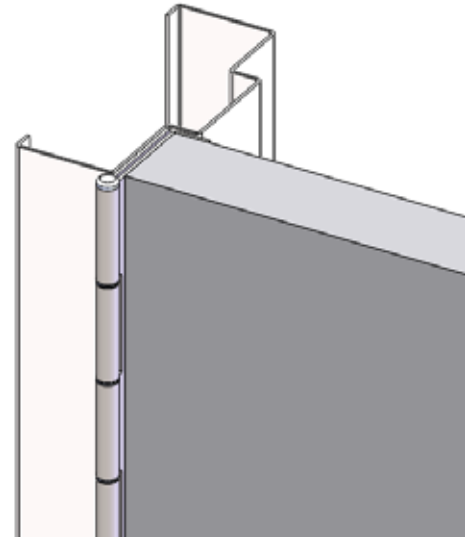

### FEATURES

- For doors 1-3/4" (44 mm) thick and up to 300 pounds
- 1/4" (6.3 mm) diameter stainless steel pin
- Dual 6/6 nylon bearings between each knuckle
- Door edge protection lip (stop side only)
- Not recommended for doors with a beveled edge on the hinge side
- 1/16" (1.6 mm) inset
- Door edge protection lip (stop side only)

Length (inches)	79"	83"	85"	95"	119"
Length (mm)	2007	2108	2159	2413	3023
Door Screws	19	21	21	23	27
Jamb Screws	19	21	21	23	27

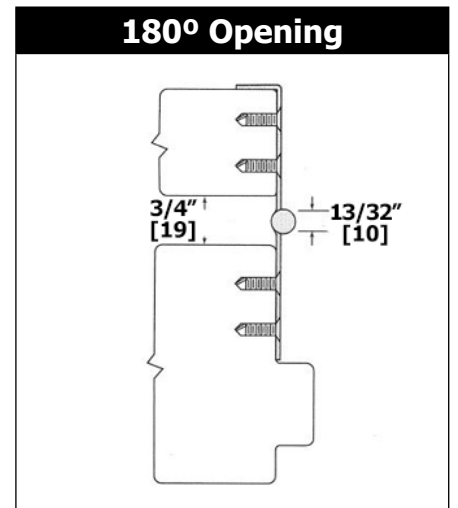
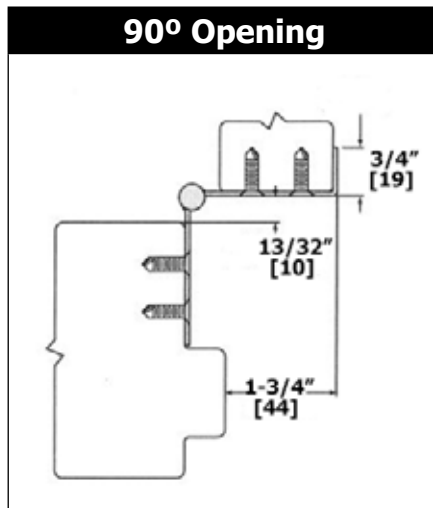
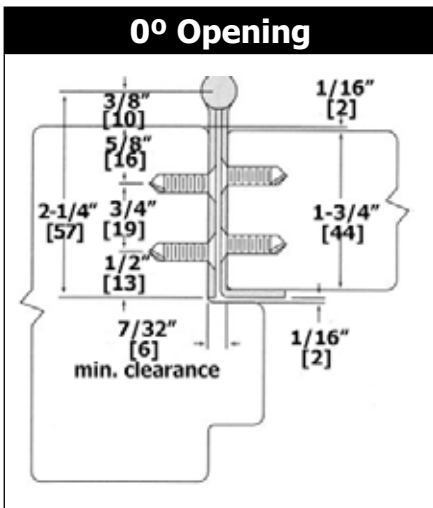

## CONCEALED LEAF - 790-926 - SWING CLEAR - DOOR OF ANY MATERIAL

### SPECIFICATIONS

Material:	14-gauge 304 stainless steel
Finish:	US32D Satin
Clearance:	9/32" (7.1 mm) minimum hinge side plus standard lockside clearance
Fasteners:	<ul style="list-style-type: none"> <li>• #10-24 x 5/8" S/S Dril-Kwik® (metal frame)</li> <li>• #10-32 x 3/4" S/S machine (used with adjustment stud)</li> <li>• #7/16-20 x 1-3/8" S/S adjustment stud (metal/wood door)</li> </ul>
Length Options:	Standard and custom lengths available
Door/Frame Reinforcements:	<ul style="list-style-type: none"> <li>• Wood – None required up to 200 lbs.</li> <li>• Metal – Recommended 16-gauge channel for heavier weight</li> <li>• For metal doors, a 1/8" (3.2 mm) thick reinforcement plate is recommended along the hinge edge for proper thread engagement of the adjustment studs</li> </ul>
Fire Rating:	Up to 3 hour metal and 90 minute wood composite

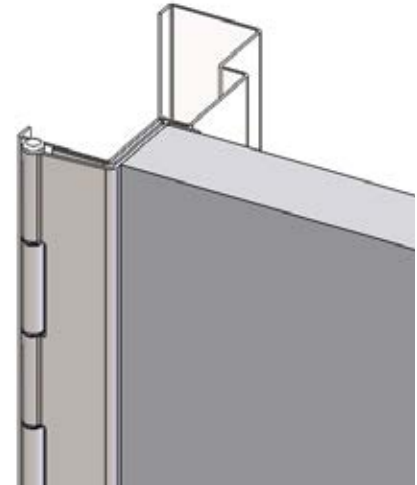

### FEATURES

- For doors 1-3/4" (44 mm) thick and up to 300 pounds
- 1/4" (6.3 mm) diameter stainless steel pin
- Dual 6/6 nylon bearings between each knuckle
- Wrap-around frame leaf design for easy installation and protection
- Door edge protection lip (stop side only)
- Useful for ADA upgrade work
- Not recommended for doors with a beveled edge on hinge side

Length (inches)	79"	83"	85"	95"	119"
Length (mm)	2007	2108	2159	2413	3023
Door Screws	19	21	21	23	27
Jamb Screws	19	21	21	23	27

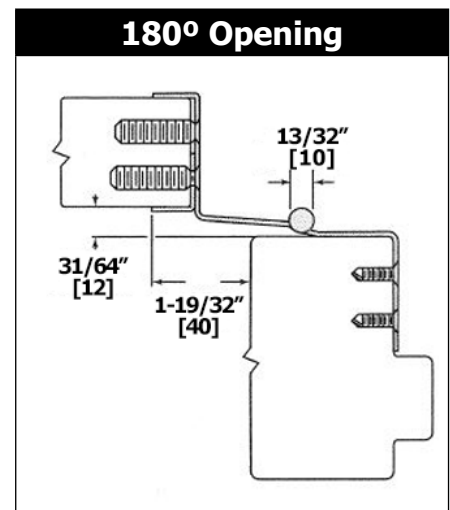
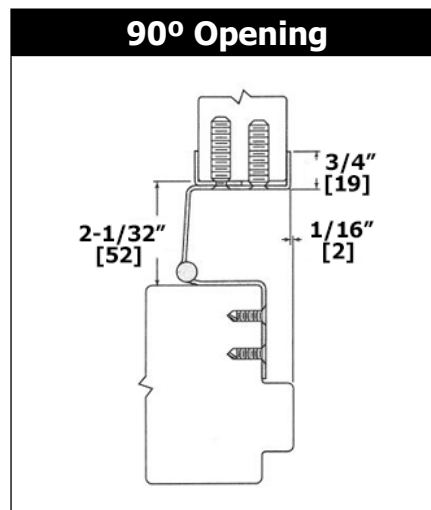
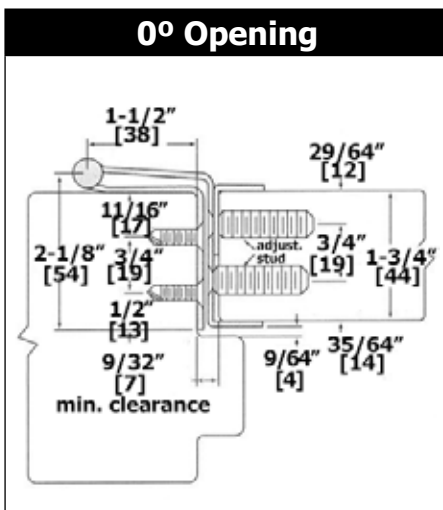



## HALF SURFACE - 790-903 - DOOR OF ANY MATERIAL

### SPECIFICATIONS

Material:	14-gauge 304 stainless steel
Finish:	US32D Satin
Clearance:	1/8" (3.2 mm) minimum hinge side plus standard lockside clearance
Fasteners:	<ul style="list-style-type: none"> <li>• #10-24 x 5/8" S/S Dril-Kwik® (metal frame)</li> <li>• #1/4-20 x 3/4" 2C Dril-Kwik® (metal door)</li> <li>• #1/4-14 x 1" 2C Type AB (wood door)</li> </ul>
Length Options:	Standard and custom lengths available
Door/Frame Reinforcements:	<ul style="list-style-type: none"> <li>• Wood – None required up to 200 lbs.</li> <li>• Metal – Recommended 16-gauge channel for heavier weight</li> <li>• For metal doors, a 1/8" (3.2 mm) thick reinforcement plate is recommended along the hinge edge for proper thread engagement of the adjustment studs</li> </ul>
Fire Rating:	Up to 3 hour metal and 90 minute wood composite

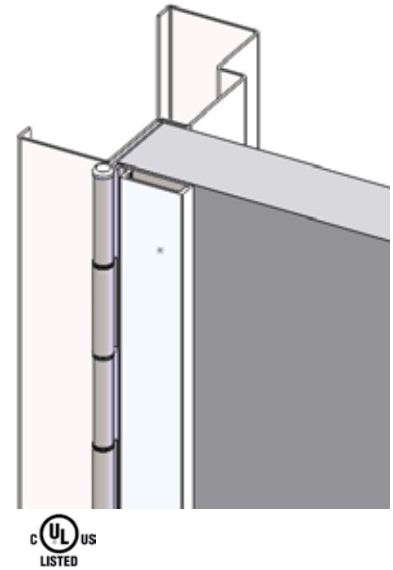

### FEATURES

- For doors 1-3/4" (44 mm) thick and up to 300 pounds
- 1/4" (6.3 mm) diameter stainless steel pin
- Dual 6/6 nylon bearings between each knuckle
- Security molding
- 1/8" (3.2 mm) inset

Length (inches)	79"	83"	85"	95"	119"
Length (mm)	2007	2108	2159	2413	3023
Door Screws	13	14	14	15	18
Jamb Screws	19	21	21	23	27

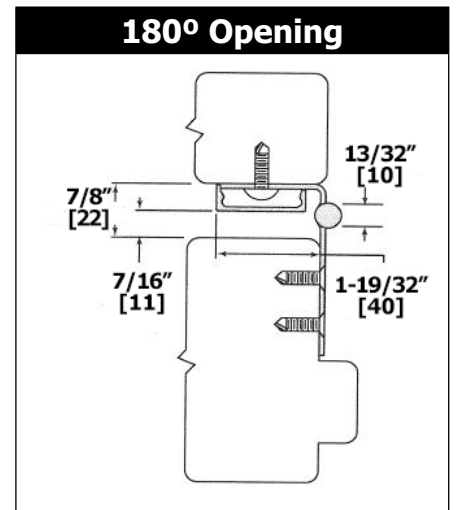
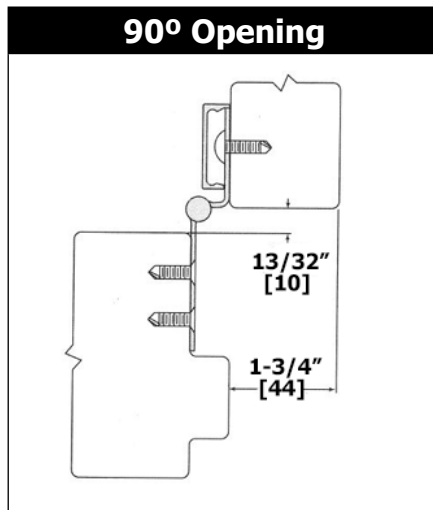
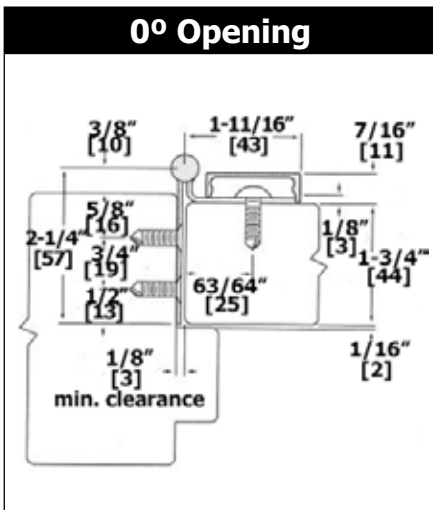

## HALF MORTISE - 790-904 - DOOR OF ANY MATERIAL

### SPECIFICATIONS

Material:	14-gauge 304 stainless steel
Finish:	US32D Satin
Clearance:	1/8" (3.2 mm) hinge side plus standard lockside clearance
Fasteners:	<ul style="list-style-type: none"> <li>• #10-24 x 5/8" S/S Dril-Kwik® (metal door)</li> <li>• #1/4-20 x 3/4" 2C Dril-Kwik® (metal frame)</li> <li>• #10-16 x 1-1/4" S/S Type AB (wood door)</li> </ul>
Length Options:	Standard and custom lengths available
Door/Frame Reinforcements:	<ul style="list-style-type: none"> <li>• Wood – None required up to 200 lbs.</li> <li>• Metal – Recommended 16-gauge channel for heavier weight</li> <li>• For metal doors, a 1/8" (3.2 mm) thick reinforcement plate is recommended along the hinge edge for proper thread engagement of the adjustment studs</li> </ul>
Fire Rating:	Up to 3 hour metal and 90 minute wood composite

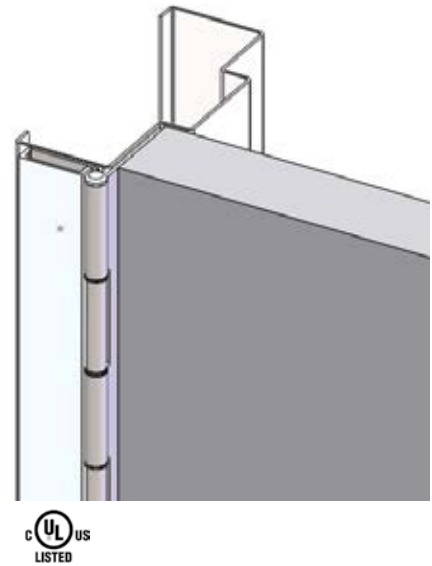

### FEATURES

- For doors 1-3/4" (44 mm) thick and up to 300 pounds
- 1/4" (6.3 mm) diameter stainless steel pin
- Dual 6/6 nylon bearings between each knuckle
- Not recommended for doors with a beveled edge on the hinge side
- 1/8" (3.2 mm) inset

Length (inches)	79"	83"	85"	95"	119"
Length (mm)	2007	2108	2159	2413	3023
Door Screws	19	21	21	23	27
Jamb Screws	13	14	14	15	18

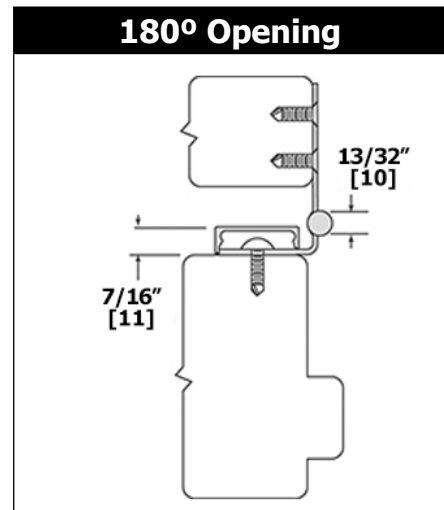
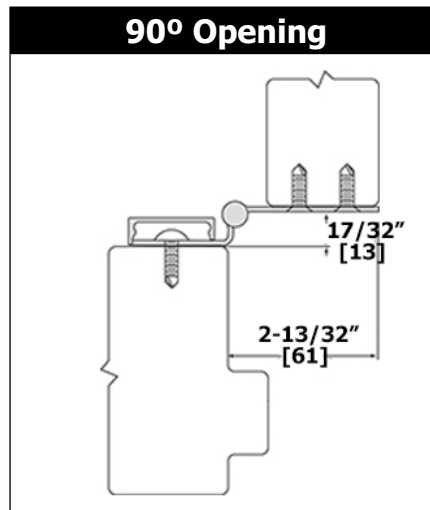
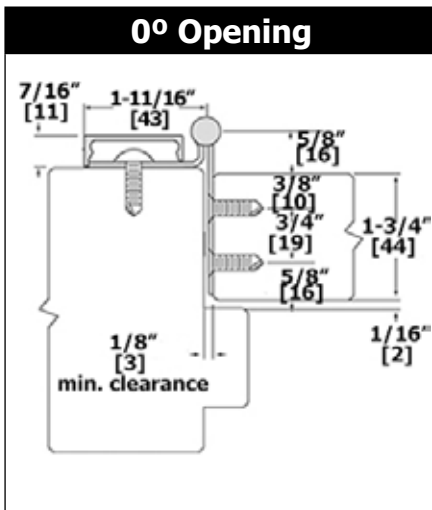





## HALF MORTISE - 790-906 - DOOR OF ANY MATERIAL

### SPECIFICATIONS

Material:	14-gauge 304 stainless steel
Finish:	US32D Satin
Clearance:	1/8" (3.2 mm) minimum hinge side plus standard lockside clearance
Fasteners:	<ul style="list-style-type: none"> <li>• #10-24 x 5/8" S/S Dril-Kwik® (metal door)</li> <li>• #1/4-20 x 3/4" 2C Dril-Kwik® (metal door)</li> <li>• #1/4-14 x 1" 2C Type AB (wood frame)</li> </ul>
Length Options:	Standard and custom lengths available
Door/Frame Reinforcements:	<ul style="list-style-type: none"> <li>• Wood – None required up to 200 lbs.</li> <li>• Metal – Recommended 16-gauge channel for heavier weight</li> <li>• For metal doors, a 1/8" (3.2 mm) thick reinforcement plate is recommended along the hinge edge for proper thread engagement of the adjustment studs</li> </ul>
Fire Rating:	Up to 3 hour metal and 90 minute wood composite

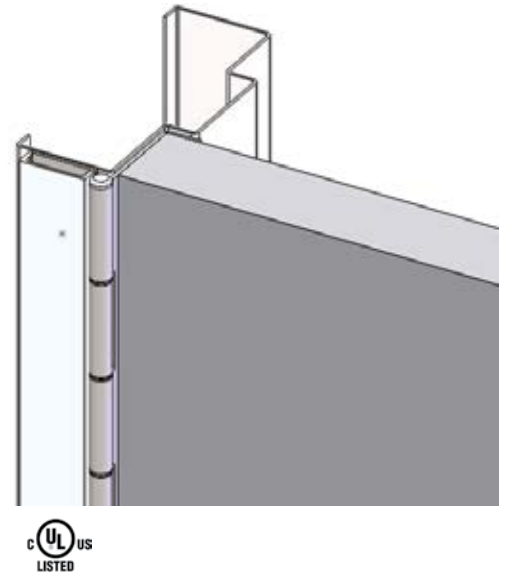

### FEATURES

- For doors 1-3/4" (44 mm) thick and up to 300 pounds
- 1/4" (6.3 mm) diameter stainless steel pin
- Dual 6/6 nylon bearings between each knuckle
- Security molding
- Door edge protection lip (stop side only)
- Not recommended for doors with a beveled edge on the hinge side

Length (inches)	79"	83"	85"	95"	119"
Length (mm)	2007	2108	2159	2413	3023
Door Screws	19	21	21	23	27
Jamb Screws	13	14	14	15	18

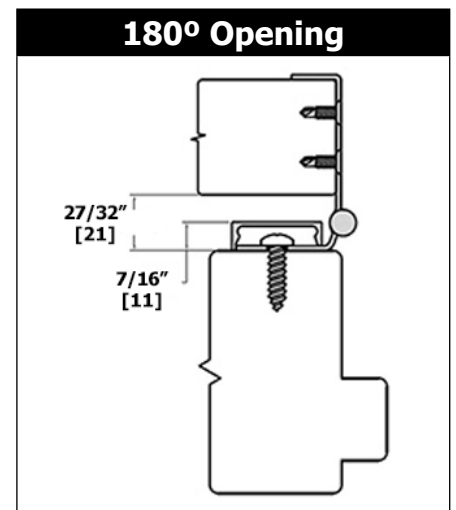
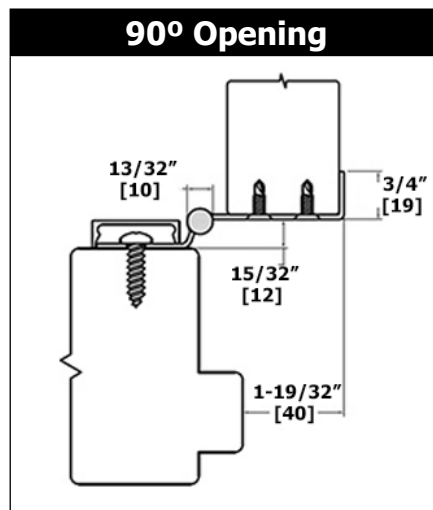
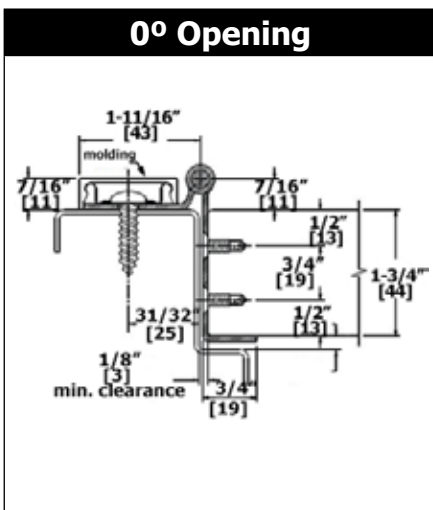

## FULL SURFACE - 790-909 - SWING CLEAR - DOOR OF ANY MATERIAL

### SPECIFICATIONS

Material:	14-gauge 304 stainless steel
Finish:	US32D Satin
Clearance:	1/8" (0.8 mm) minimum recommended hinge side plus standard lockside clearance
Fasteners:	<ul style="list-style-type: none"> <li>• #10-24 x 5/8" S/S Dril-Kwik® (metal frame)</li> <li>• #1/4-20 x 3/4" 2C Dril-Kwik® (metal door)</li> <li>• #1/4-14 x 1" 2C Type AB (wood door)</li> </ul>
Length Options:	Standard and custom lengths available
Door/Frame Reinforcements:	<ul style="list-style-type: none"> <li>• Wood – None required up to 200 lbs.</li> <li>• Metal – Recommended 16-gauge channel for heavier weight</li> <li>• For metal doors, a 1/8" (3.2 mm) thick reinforcement plate is recommended along the hinge edge for proper thread engagement of the adjustment studs</li> </ul>
Fire Rating:	Up to 3 hour metal and 90 minute wood composite

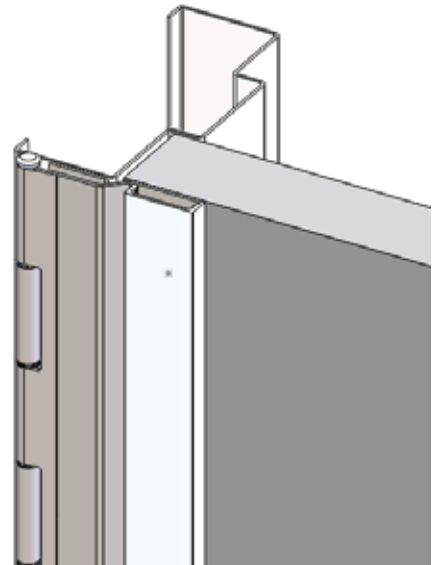

### FEATURES

- For doors 1-3/4" (44 mm) thick and up to 300 pounds
- 1/4" (6.3 mm) diameter stainless steel pin
- Dual 6/6 nylon bearings between each knuckle
- Useful for ADA upgrade work
- Security molding
- For beveled or square edge doors
- 1/8" (3.2 mm) inset

Length (inches)	79"	83"	85"	95"	119"
Length (mm)	2007	2108	2159	2413	3023
Door Screws	19	21	21	23	27
Jamb Screws	13	14	14	15	18

