

SDC Security Door Controls

801 Avenida Acaso, Camarillo, Ca. 93012 • (805) 494-0622 •
www.sdcsecurity.com • E-mail: service@sdsecurity.com

INSTALLATION INSTRUCTIONS LR100CAK-EM ELECTRIC LATCH RETRACTION DEVICE KIT CAL-ROYAL MODELS: 2200, F2200, 2260, F2260, 9800, F9800, 9860 & F9860

Step 1

Remove access cover. Disconnect and discard all dogging components. Then remove the two pre-existing screws from the device.

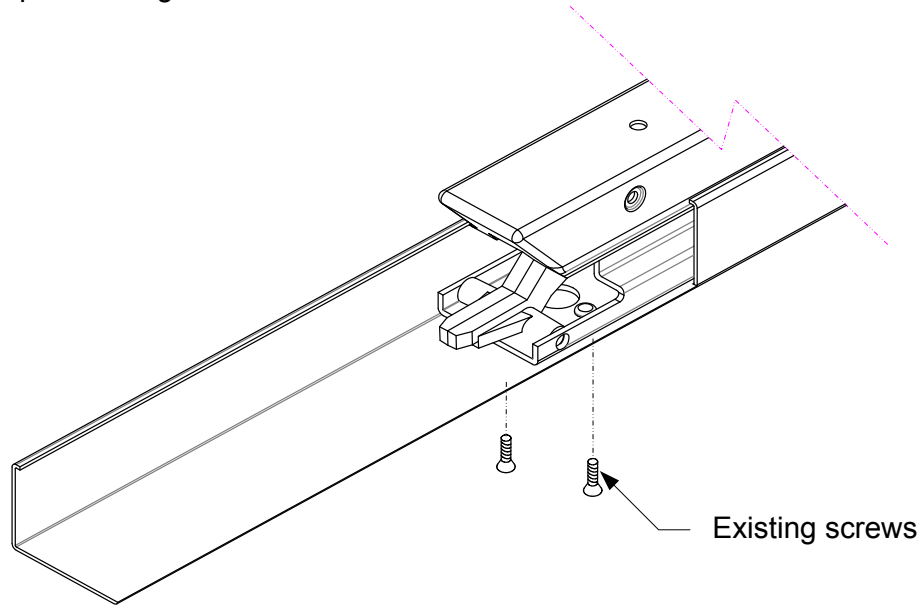

Step 2

Slide the ELR assembly into the housing and under the hinge bracket. Position the roller at the front of the ELR under the pivot arm of the push bar.

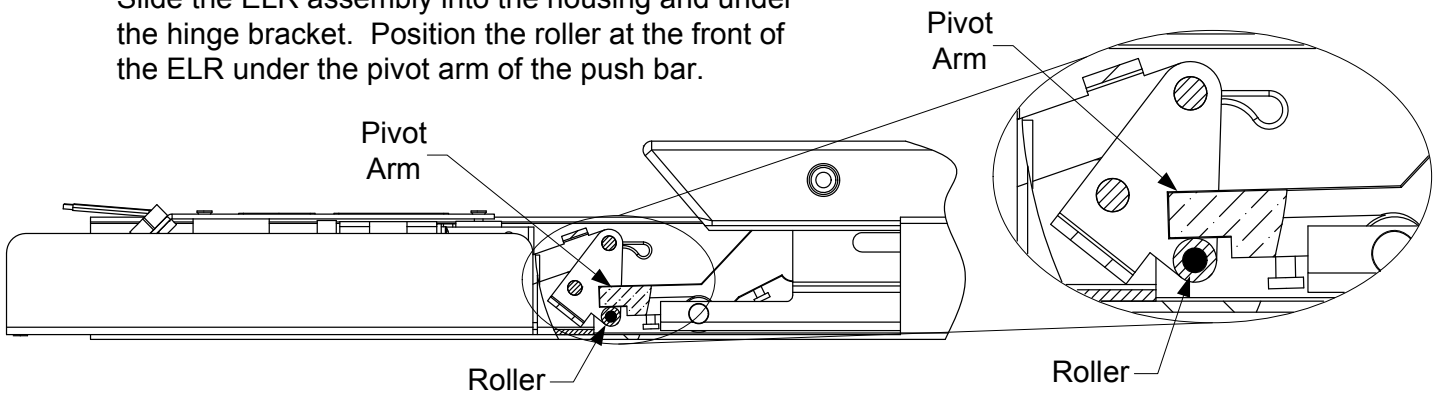

Retrofit Installation Note: 42" or 48" exit devices that have been modified to fit a 36" or smaller opening, may not have the required space to fit the standard E. L. R. assembly. Always verify the distance from the end of the touchpad to the end rail, and if necessary, consult with the factory for appropriate selection.

Any suggestions or comments to this instruction or product are welcome. Please contact us through our website or email engineer@sdsecurity.com

Step 3

Once ELR is in place re-fasten the exit device screws and secure the ELR in place.

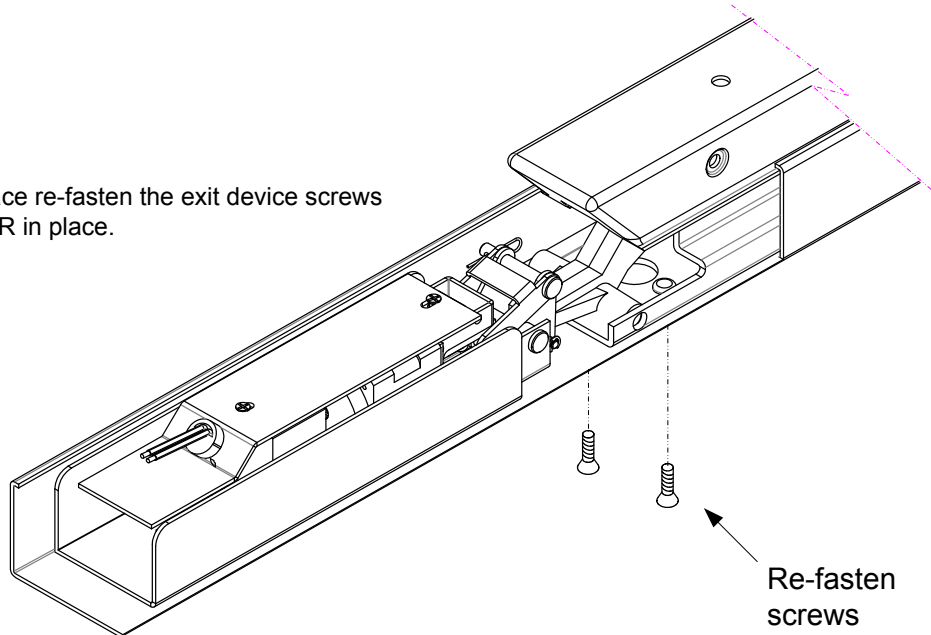

Step 4

Wire the ELR unit to the supplied PC board as shown below.

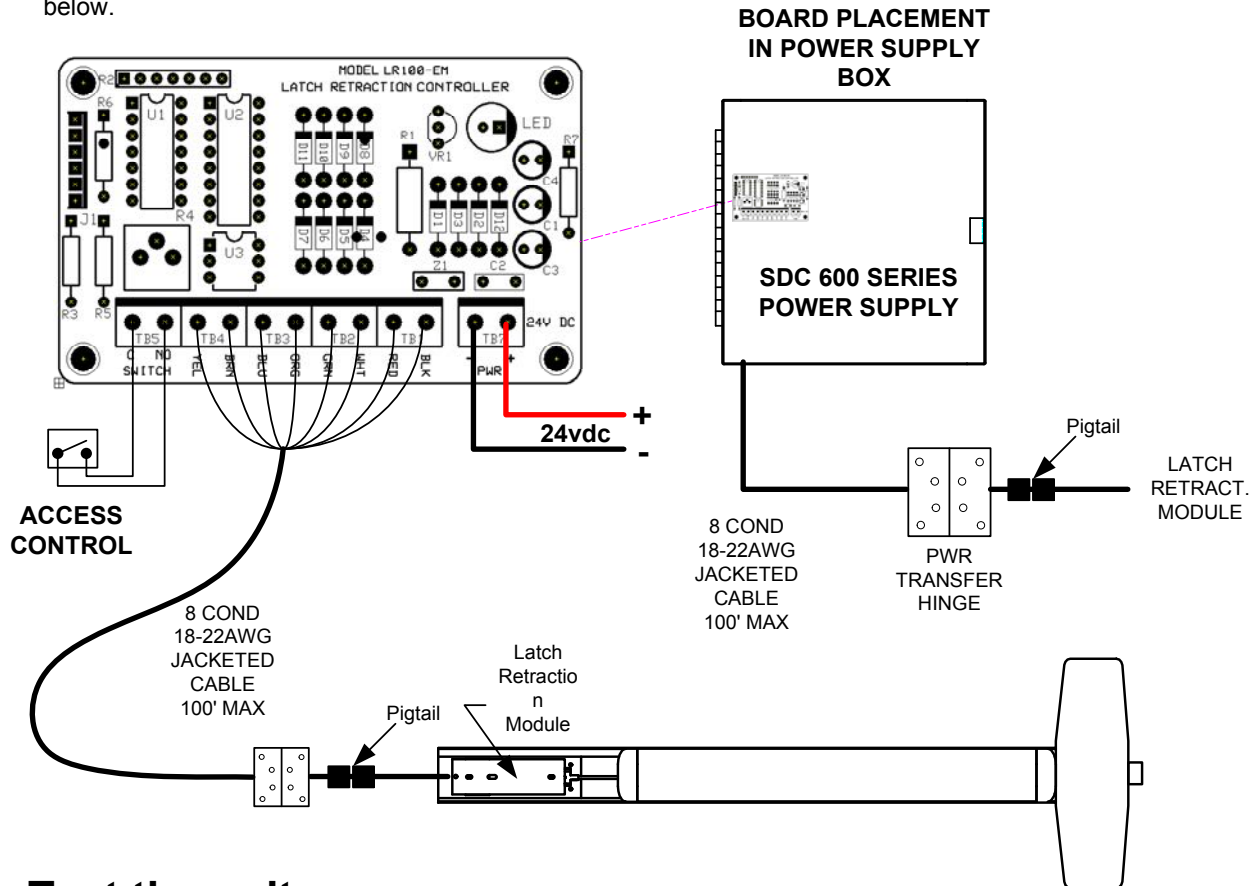

Test the unit

Wire the unit and test function. Reinstall the cover (in reverse) and end cap.

ELECTRICAL DATA
 24VDC @ 700/200mA
 RED (+) BLK (-)
 PATENT #8,851,530