

SDC Security Door Controls

801 Avenida Acaso, Camarillo, Ca. 93012 • (805) 494-0622 •
www.sdcsecurity.com • E-mail: service@sdsecurity.com

INSTALLATION INSTRUCTIONS LR100IDCK ELECTRIC LATCH RETRACTION DEVICE KIT

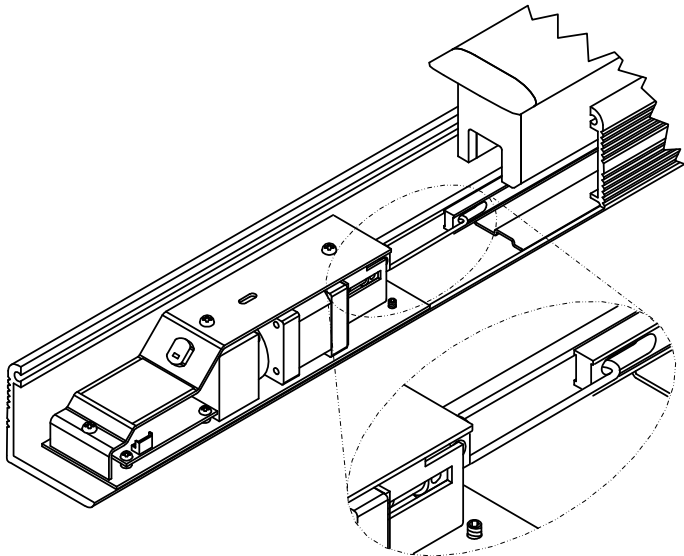

ELECTRICAL DATA
24VDC @ 500/180mA
RED (+) BLK (-)
PATENT PENDING

Step 1

Slide the Electric Latch Retraction assembly into device and attach the linkage to the latch retraction rod.

Step 2

Carefully slide the assembly back out until the linkage **JUST** makes contact with the latch retraction rod. Tighten set screws.

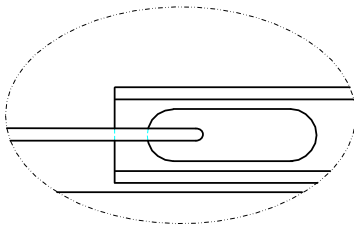

TIGHTEN SET
SCREWS TO
LOCK DEVICE
IN POSITION

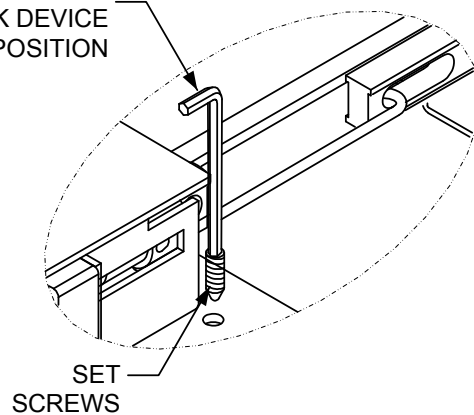

NOTE Retro-Fitting Vertical Rod Devices:

Before retro-fitting an electric latch assembly into a vertical device, the following must be done to ensure proper alignment. Disconnect the vertical rods from the device. Install the electric latch assembly as shown above. Once the ELR is properly installed energize it so that the push pad is dogged down, by doing so it will allow for proper alignment for the vertical rods. Finally reconnect the vertical rods to the device and make the proper adjustments.