

SDC Security Door Controls

801 Avenida Acaso, Camarillo, Ca. 93012 • (805) 494-0622 •
www.sdcsecurity.com • E-mail: service@sdsecurity.com

INSTALLATION INSTRUCTIONS LR100JAK ELECTRIC LATCH RETRACTION DEVICE KIT JACKSON EXIT DEVICES MODELS: 2085 & 2095

STEP #1:

Remove the end cap and back cover from the exit device. Remove all existing dogging components. Remove device head in order to access the push bar insert. Loosen the set screw in the front of the push bar and slide the insert away from the push bar end cap. Replace the Push Bar end cap with end cap 7194 provided. Slide the insert back into position, tighten the set screw and secure the device head. Slide the LR100 assembly into position.

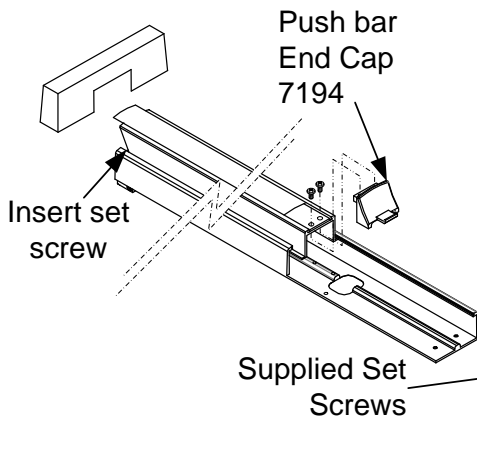

LR00JAK
Jackson
Device
ELR

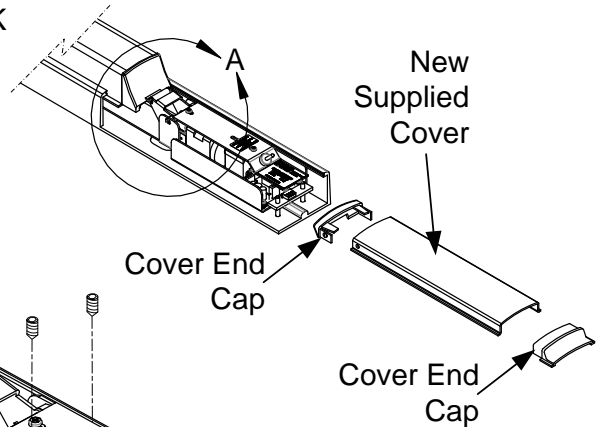

STEP #2:

Install the ELR roller clevis assembly over the top of the push bar end cap 7194. When properly aligned, tighten the two supplied set screws to lock in place as shown in detail A.

STEP #3:

Wire the unit and test operation.
Reinstall the new cover and end caps.
Orient the cover and end caps as shown.

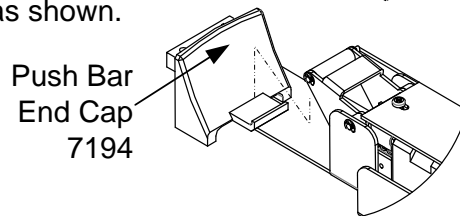

<p>ELECTRICAL DATA 24VDC @ 1A max. RED (+) BLK (-) PATENT #8,851,530 PATENT PENDING</p>
--

Note Retrofitting Vertical Rod Devices: Before Retro-fitting an Electric Latch Assembly into a Vertical Device, the following must be done to ensure proper alignment. Disconnect the vertical rods from the device. Install the Electric Latch Assembly as shown. Once the ELR is properly installed, energize it so that the Push Pad is Dogged down. By doing so, it will allow for the proper alignment of the Vertical Rods. Finally, re-connect the Vertical Rods to the device and make the proper adjustment.

Any suggestions or comments to this instruction or product are welcome. Please contact us through our website or email engineer@sdsecurity.com