

# SDC Security Door Controls

801 Avenida Acaso, Camarillo, Ca. 93012 • (805) 494-0622 •  
www.sdcsecurity.com • E-mail: service@sdsecurity.com

## INSTALLATION INSTRUCTIONS LR100PDQK ELECTRIC LATCH RETRACTION DEVICE KIT MODELS: 6200R & 6200V

<b>ELECTRICAL DATA</b>	
24VDC @ 700/200mA	
RED (+)	BLK (-)
PATENT #8,851,530	

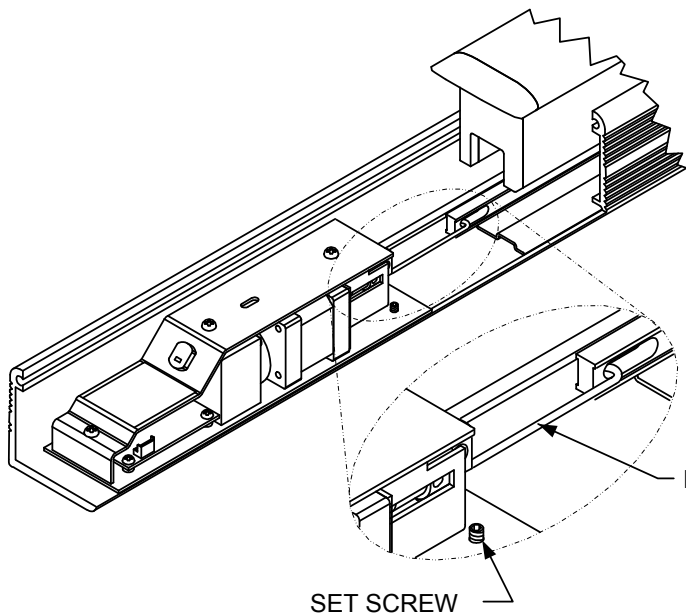

### **Step 1**

Remove and discard dogging from device. Slide the Electric Latch Retraction assembly into device and attach the linkage to the latch retraction rod (short linkage for standard, long linkage for 4' device).

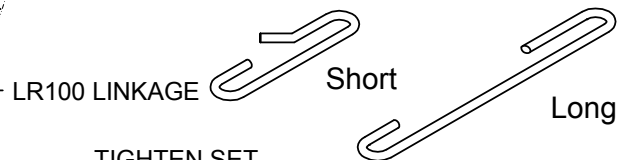

TIGHTEN SET SCREWS TO LOCK DEVICE IN POSITION

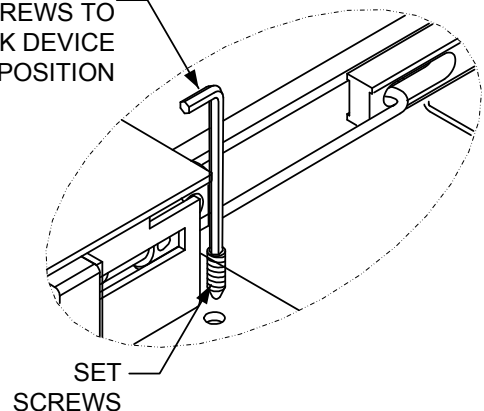

### **Step 2**

Carefully slide the assembly back out until the linkage JUST makes contact with the latch retraction rod. Tighten set screws.

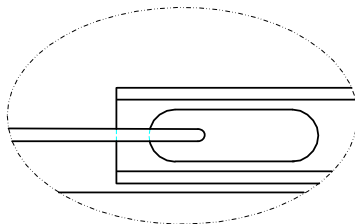

**Retrofit Installation Note:** 42" or 48" exit devices that have been modified to fit a 36" or smaller opening, may not have the required space to fit the standard E. L. R. assembly. Always verify the distance from the end of the touchpad to the end rail, and if necessary, consult with the factory for appropriate selection.

### **NOTE Retro-Fitting Vertical Rod Devices:**

Before retro-fitting an electric latch assembly into a vertical device, the following must be done to ensure proper alignment. Disconnect the vertical rods from the device. Install the electric latch assembly as shown above. Once the ELR is properly installed energize it so that the push pad is dogged down, by doing so it will allow for proper alignment for the vertical rods. Finally reconnect the vertical rods to the device and make the proper adjustments.

Any suggestions or comments to this instruction or product are welcome. Please contact us through our website or email engineer@sdsecurity.com