

SDC Security Door Controls

801 Avenida Acaso, Camarillo, Ca. 93012 • (805) 494-0622 •
www.sdcsecurity.com • E-mail: service@sdsecurity.com

INSTALLATION INSTRUCTIONS LR100TEK ELECTRIC LATCH RETRACTION DEVICE KIT TELL EXIT DEVICES MODELS: 9400 & 9500

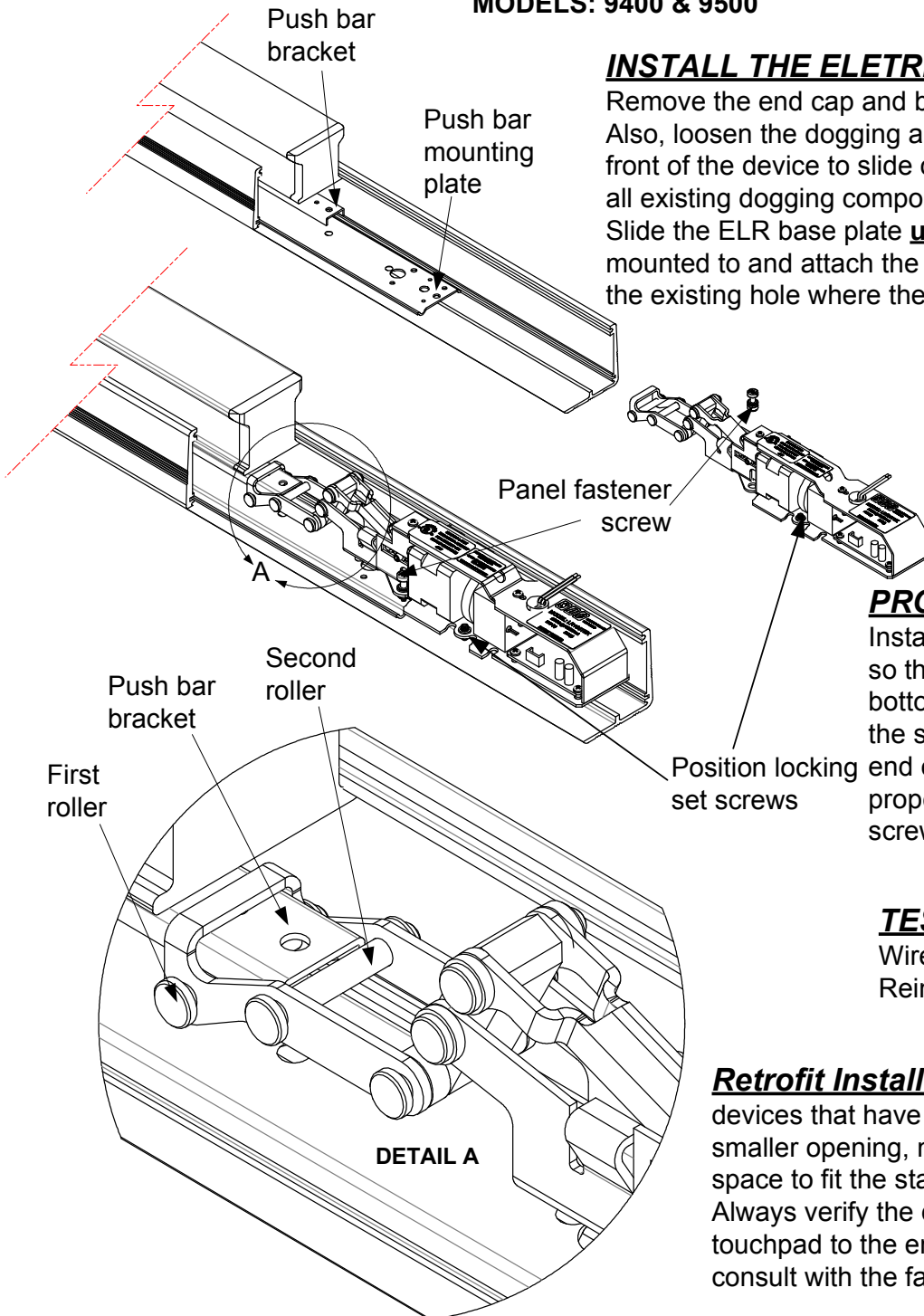

INSTALL THE ELETRIC LATCH RETRACTOR:

Remove the end cap and back cover from the exit device. Also, loosen the dogging and remove the two screws at the front of the device to slide off the device housing. Remove all existing dogging components and re-install the housing. Slide the ELR base plate **under** the plate the push bar is mounted to and attach the supplied panel fastener screw to the existing hole where the dogging was mounted.

ELECTRICAL DATA	
24VDC @ 700/200mA	
RED (+)	BLK (-)
PATENT #8,851,530	

PROPER ORIENTATION:

Install the ELR roller clevis assembly so the first roller travels over the bottom of the push bar bracket, and the second roller butts up against the end of the push bar bracket. When properly aligned, tighten the two set screws to lock in place.

TEST UNIT:

Wire the unit and test function.
Reinstall the back cover and end cap.

Retrofit Installation Note: 42" or 48" exit devices that have been modified to fit a 36" or smaller opening, may not have the required space to fit the standard E. L. R. assembly. Always verify the distance from the end of the touchpad to the end rail, and if necessary, consult with the factory for appropriate selection.

Any suggestions or comments to this instruction or product are welcome. Please contact us through our website or email engineer@sdsecurity.com