

# SDC Security Door Controls

801 Avenida Acaso, Camarillo, Ca. 93012 • (805) 494-0622 •  
www.sdcsecurity.com • E-mail: service@sdsecurity.com

## INSTALLATION INSTRUCTIONS LR100TSK-65/67 ELECTRIC LATCH RETRACTION DEVICE KIT TOWN STEEL MODELS: ED6500 & ED6700

### Step 1

Remove access cover. Disconnect and discard all dogging components. Then remove the two pre-existing screws from the device.

<b>ELECTRICAL DATA</b> 24VDC @ 700/200mA RED (+) BLK (-) PATENT #8,851,530
---

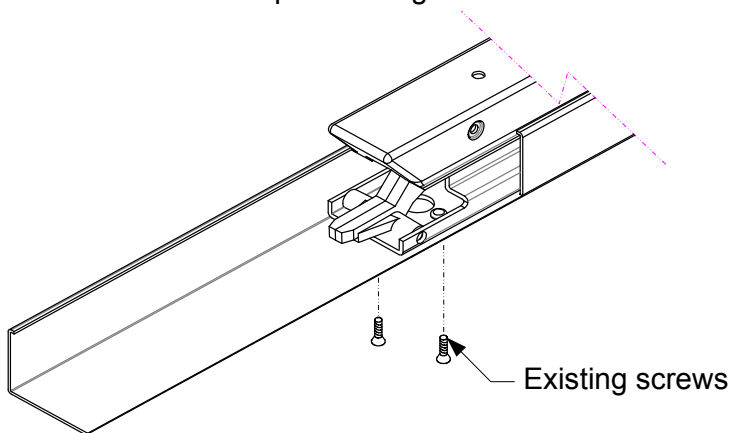

### Step 2

Slide the ELR assembly into the housing and under the hinge bracket. Position the roller at the front of the ELR under the pivot arm of the push bar.

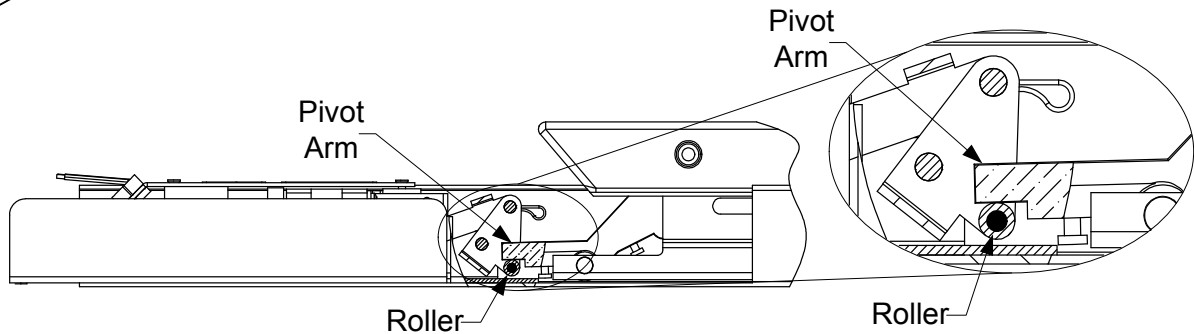

### Step 3

Once ELR is in place re-fasten the exit device screws and secure the ELR in place.

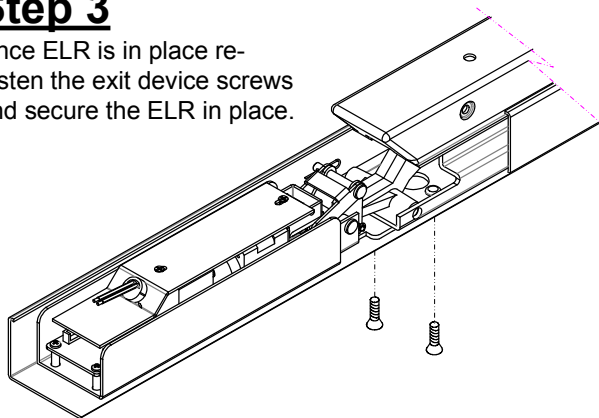

### Test the unit

Wire the unit and test function.  
Reinstall the cover and end cap.

**Retrofit Installation Note:** 42" or 48" exit devices that have been modified to fit a 36" or smaller opening, may not have the required space to fit the standard E. L. R. assembly. Always verify the distance from the end of the touchpad to the end rail, and if necessary, consult with the factory for appropriate selection.

Any suggestions or comments to this instruction or product are welcome. Please contact us through our website or email [engineer@sdsecurity.com](mailto:engineer@sdsecurity.com)