

SDC Security Door Controls

801 Avenida Acaso, Camarillo, Ca. 93012 • (805) 494-0622 •
www.sdcsecurity.com • E-mail: service@sdsecurity.com

LRK2R INSTALLATION INSTRUCTIONS LATCH/REX SWITCH KIT

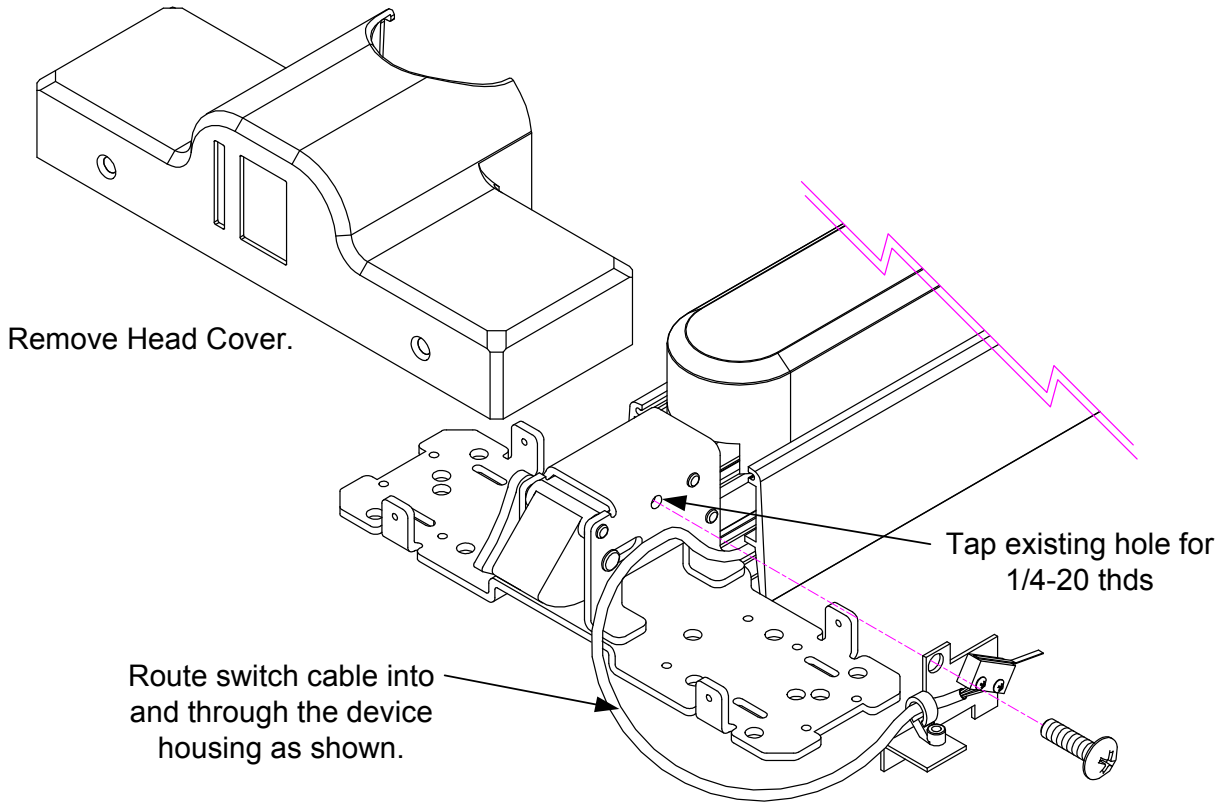

Switch arm may require slight adjustment to make proper contact on Push Bar.

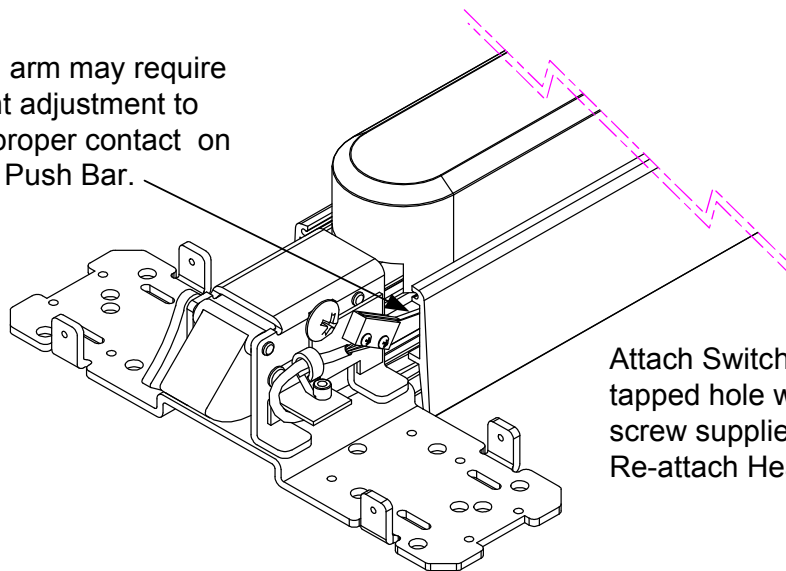

WIRING
COM – WHT
N/O – RED
N/C - GRN

Attach Switch Assembly to tapped hole with the 1/4-20 screw supplied. Re-attach Head Cover.