

# SDC SECURITY DOOR CONTROLS

801 Avenida Acaso, Camarillo, Ca. 93012 • (805) 494-0622 • Fax: (805) 494-8861  
 www.sdcsecurity.com • E-mail: service@sdsecurity.com

## LRP1L INSTALLATION INSTRUCTIONS LATCH SWITCH KIT PHI/STANLEY 2000 SERIES RIM DEVICE

Remove the four screws securing the Head Assembly Cover Plate. Insert the Magnet Assembly under the existing Latch Return Spring. Attach Cable Tie where shown using the supplied screw. Re-Attach the Head Assembly Cover Plate, using one of the existing screws to secure the Switch Bracket as shown.

**\*NOTE:** Regardless of handing, the Cable Tie must always be fastened to the "LHR" side of the device.

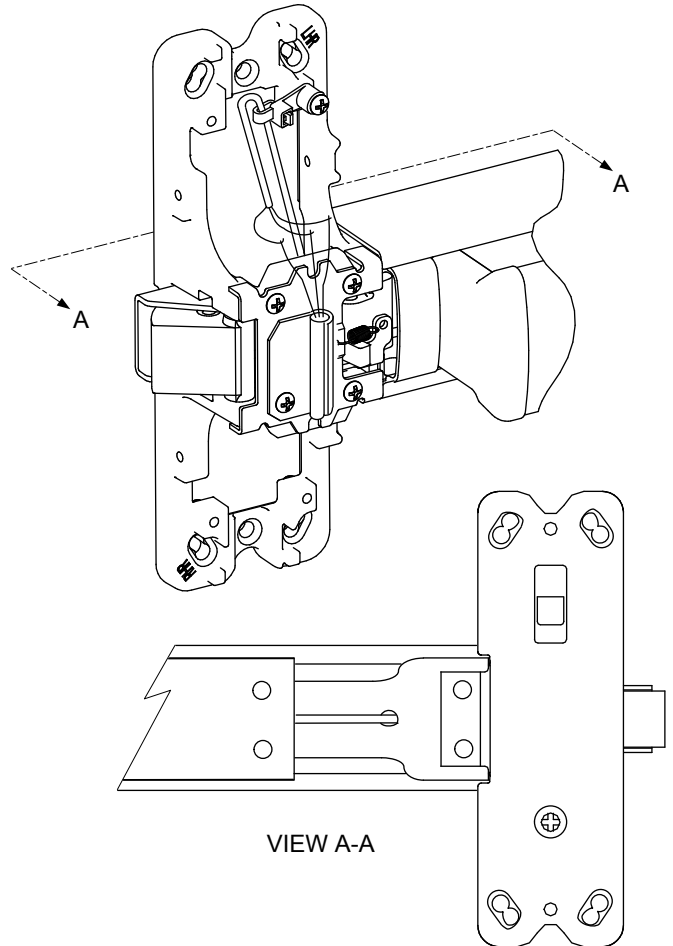
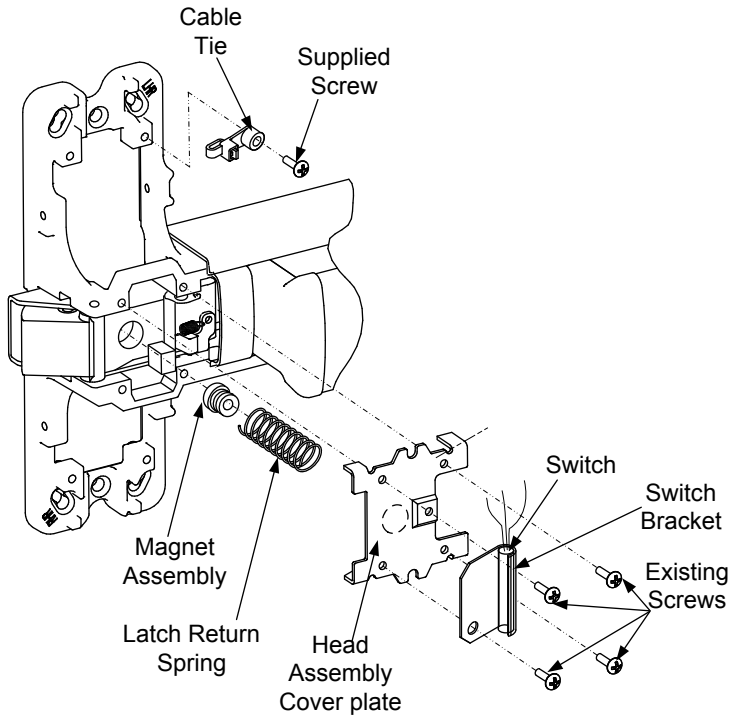

BLK – COM  
 RED – N/C  
 WHT – N/O  
 200mA @ 30VAC RESISTIVE

Route cable wire thru cable tie as shown and back inside under the push bar. Come out the hole at the back of mounting rail and route cable through the bar.

### Applications

**Remote Latch Status Monitoring:** Retracting the latch by depressing the push pad provides an output signal for local or remote visual and audible annunciation indicating forced entry or unauthorized egress.