

# **SDC** Security Door Controls

801 Avenida Acaso, Camarillo, Ca. 93012 • (805) 494-0622 •  
www.sdcsecurity.com • E-mail: service@sdsecurity.com

## **LRTS2R INSTALLATION INSTRUCTIONS REX MONITORING KIT TOWN STEEL ED5500 SERIES**

### **Step 1**

Remove the four screws at the front of the device (shown) and disconnect the head.

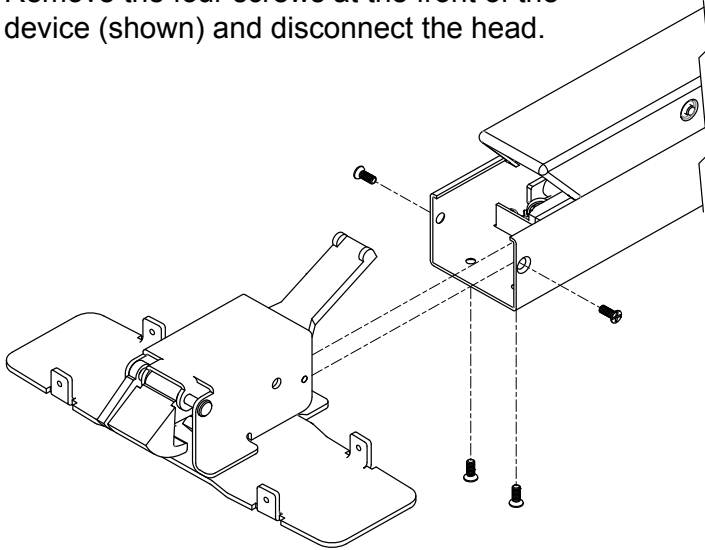

### **Step 2**

Remove the front two screws connecting the push pad to the housing. Route the wires along the side of the housing and out the back. Slide the LRTS2R into the housing under the push pad mounting bracket.

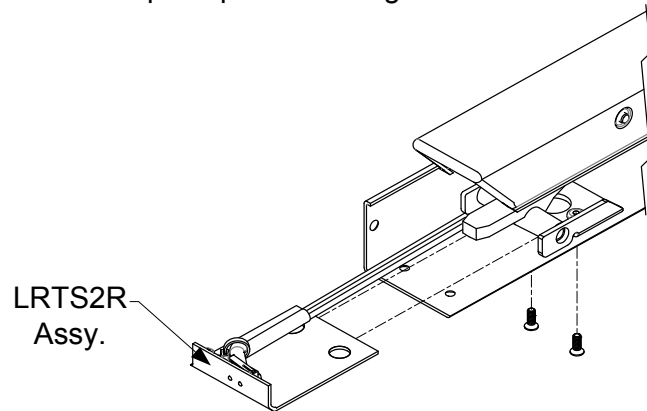

### **Step 3**

Once the REX unit is in place, re-attach the push pad on top of LRTS2R.

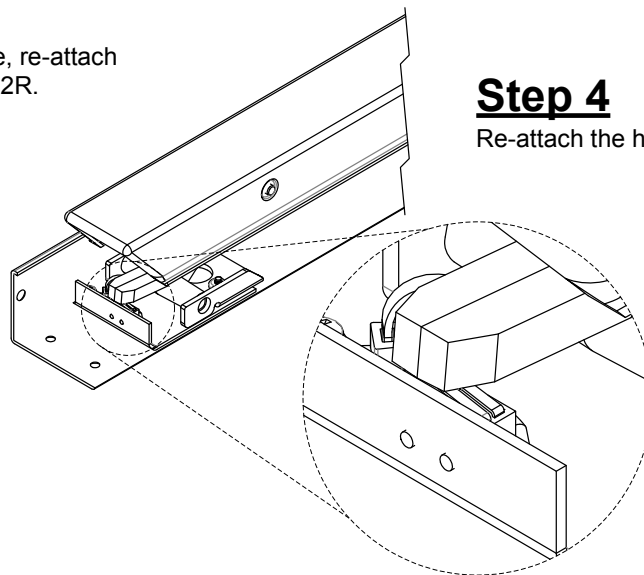

### **Step 4**

Re-attach the head, and test the unit.

BLK – COM  
BLU – N/C  
RED – N/O  
3 Amp @ 125 VAC  
Resistive

Any suggestions or comments to this instruction or product are welcome. Please contact us through our website or email engineer@sdsecurity.com