

ITL 2000

Electronic Safe Dialer

Operates without supervision - set up and run until combination lock opens

Eliminates need for:

- external computer
- extra equipment
- drilling

Wheels can be dialed:

- to every possible safe lock combination
- through a specific range of numbers

Compact carrying case includes all tools required for the job

Warranty: One year parts and labor

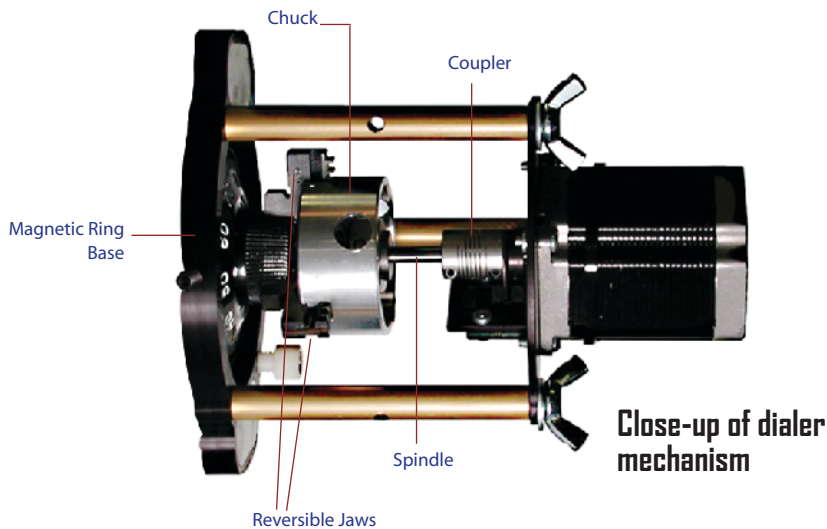
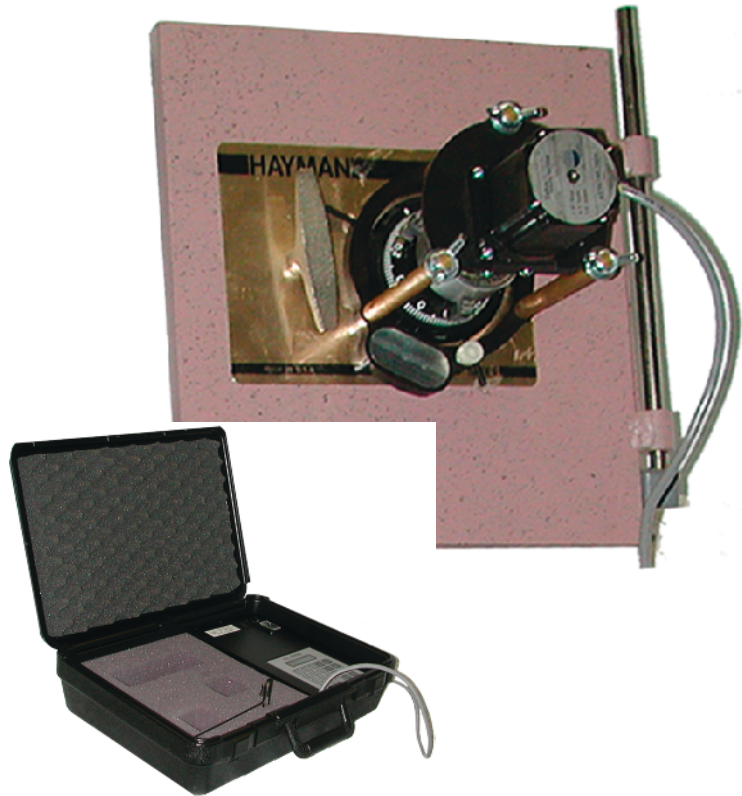

MACHINE SPECIFICATIONS

Power: 120 volt AC .75 amp or
240 volt AC .5 amp 50/60 Hz

Keypad: Sealed membrane

Display: 2 lines
16 characters per line

Dimensions (LxWxH): 14" x 18" x 6"
355 x 457 x 152mm

Net Weight: 15lbs
7kg

Gross Weight: 16lbs
7.25kg

Optional extras:

- MA 20006 - adjustable mount plate kit
- MA 01021 - jaw set for larger dials

Distributed by:

INTRALOCK
TOOLS LIMITED

Building superior key machines since 1985

www.intralocktools.com