

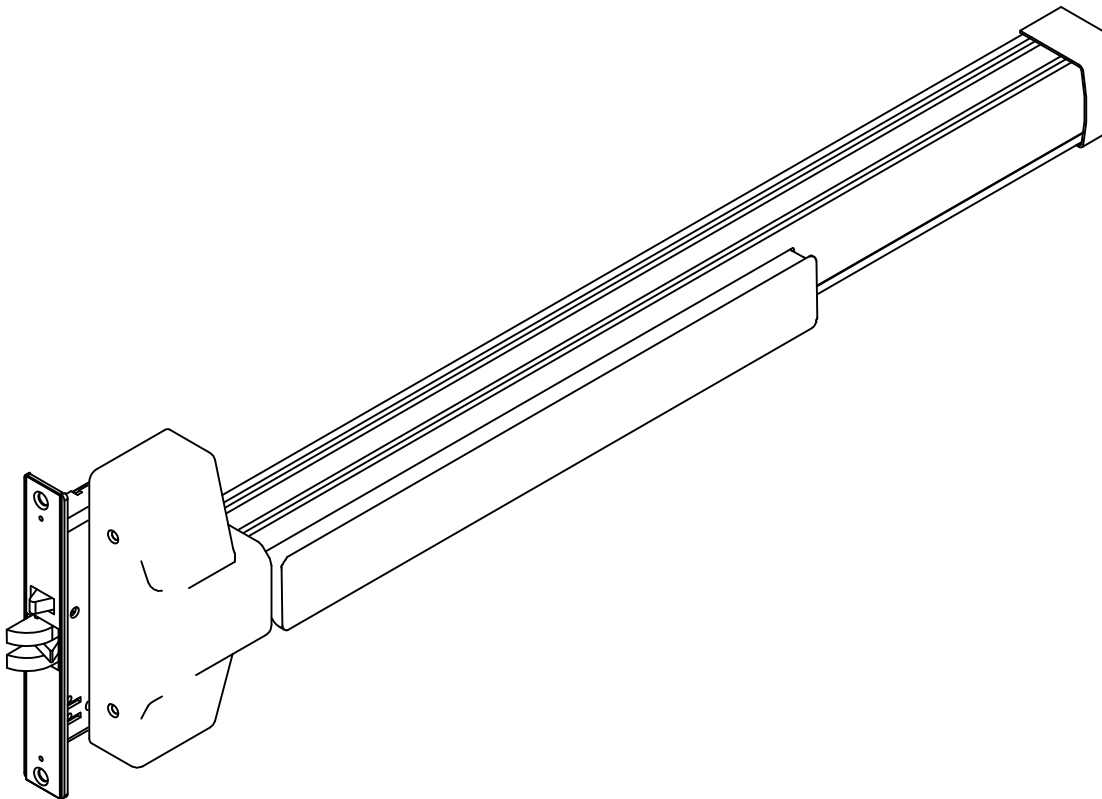

801 Avenida Acaso, Camarillo, Ca. 93012
• (805) 494-0622 • www.sdcsecurity.com
E-mail: service@sdsecurity.com

Security Door Controls

S6300 SERIES REVERSIBLE PANIC/FIRE EXIT MORTISE LOCK DEVICES INSTALLATION INSTRUCTIONS



These instructions are presented a in step by step sequence.

Please read it through **before** installation.

Note: The dimensions of the Template are shown in inches. See attached page for the Metric Conversion Table for millimeters.

DESIGNATION OF PARTS

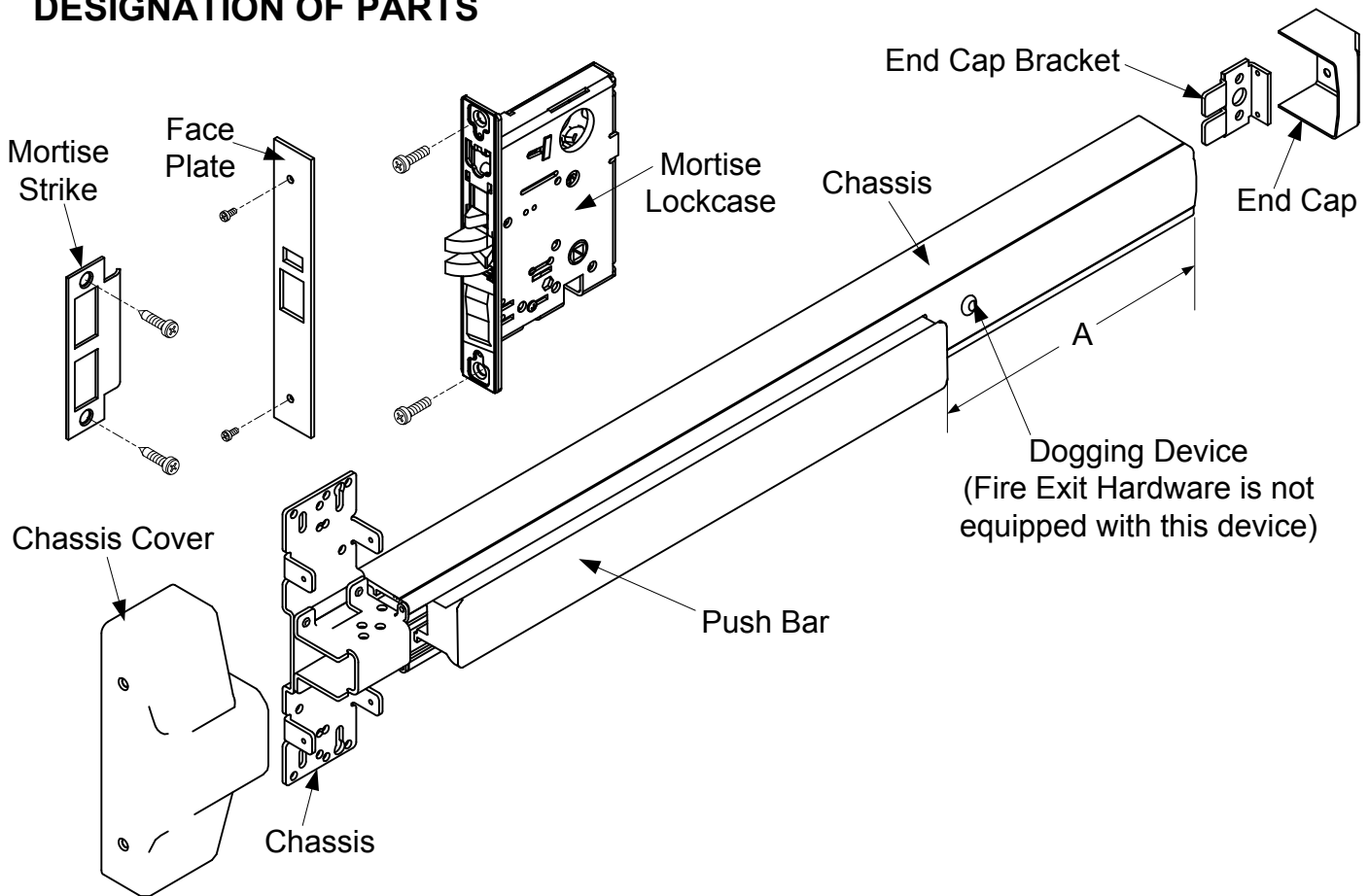

BEFORE INSTALLING THIS EXIT DEVICE :

1. Check device to be sure the type is correct for the application
2. Check device for the correct length, finish and outside trim to be used.

NOTE: This model device has 3 different lengths:

For use on 3' wide door device = approx. 33"
For use on 3-1/2' wide door device = approx. 40"
For use on 4' wide door device = approx 44"

The lengths of devices are precut for 36", 42" and 48" wide door use, no additional cutting is necessary. If narrow door installation is required, cut device at "A" portion to door width minus 4" to fit properly.

1. MARK DOOR FOR DEVICE AND LOCK

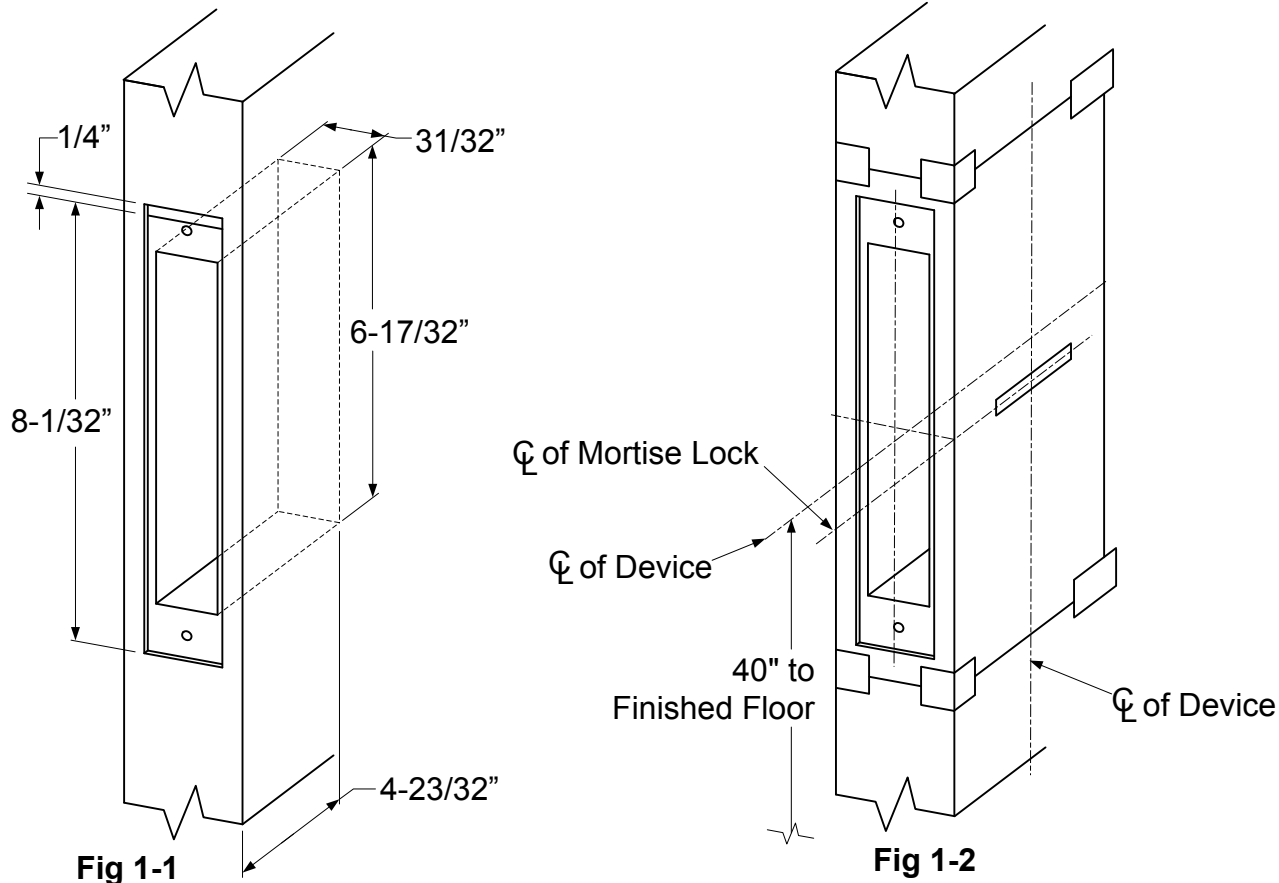

1. If door is already cut out for lock (mortised), check for proper clearance (Fig 1-1).
2. Mark the center line of device by drawing a line across the door 40" above finished floor (Fig 1-2).
3. Tape template to door and frame then mark mounting holes for device chassis and strike.
4. Cut-out and drill holes as marked on door and frame.

2. INSTALL STRIKE TO FRAME OR INACTIVE DOOR

1. Install strike to drilled position on frame or inactive door and secure in place with supplied screws (Fig 2-1 & 2-2).
2. Be sure auxiliary latch of lock does not enter strike opening.

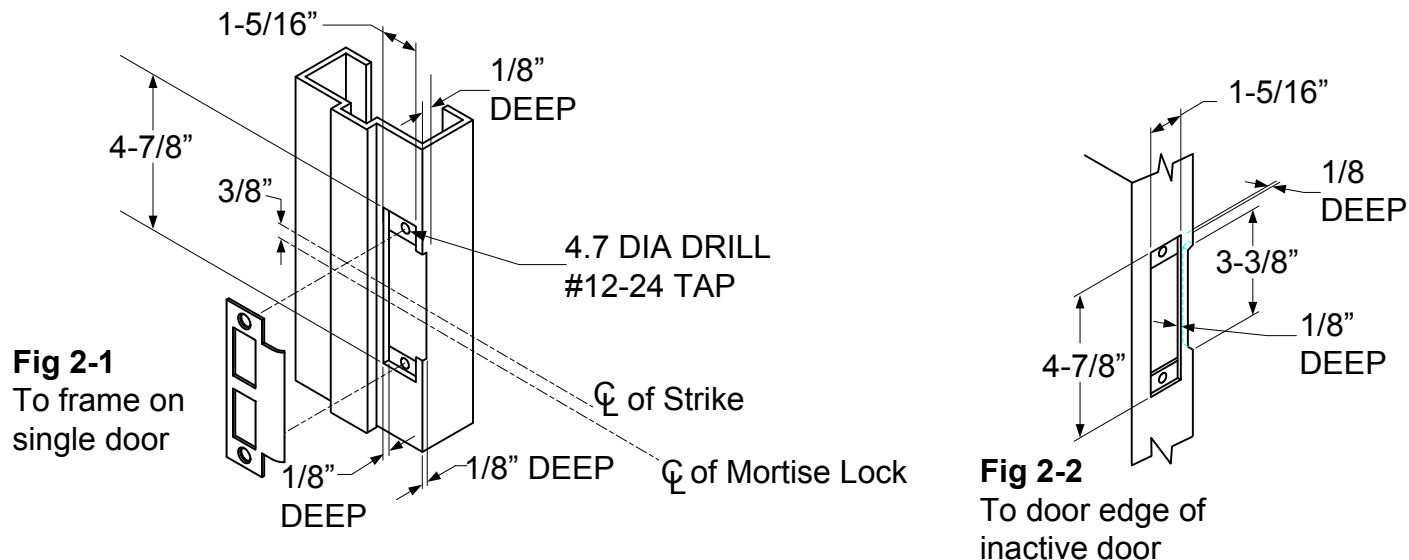

3. SET LOCK HANDING

A) Set the lock for proper handing to match door hand.

1) Change latch bolt handing:

If the handing of the latch bolt doesn't match door hand, remove fixing screw and pull latch bolt out from lock case. Turn complete latch bolt unit around to match door handing. Reinstall latch bolt and fasten it in place (Fig 3-1 & 3-2).

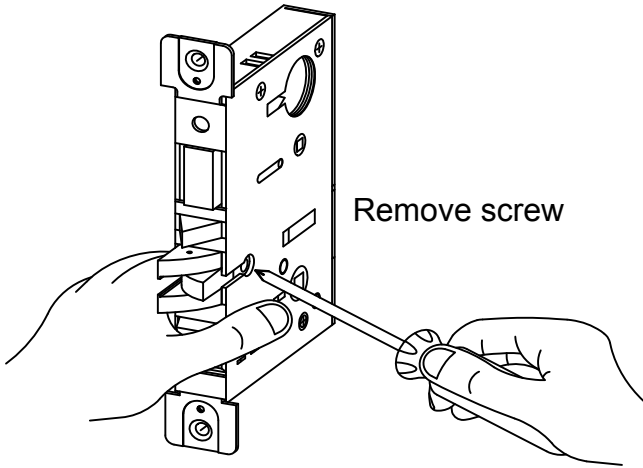

Fig 3-1

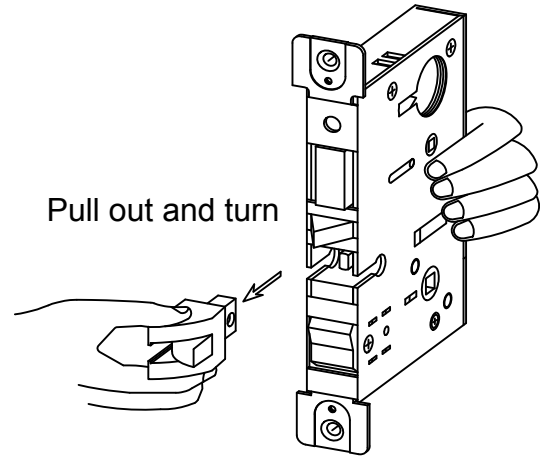

Fig 3-2

2) Set outside hand of lock case:

There are two catch screws of lock hand on both sides of chassis. Take catch screw out from one side of chassis which is going to face outside of door (Fig 3-3). Another catch screw must always be on inside of chassis. For RH and RHRB, the catch screw will be on the lock case side. For LH and LHRB, the catch screw will be on the lock case cover side.

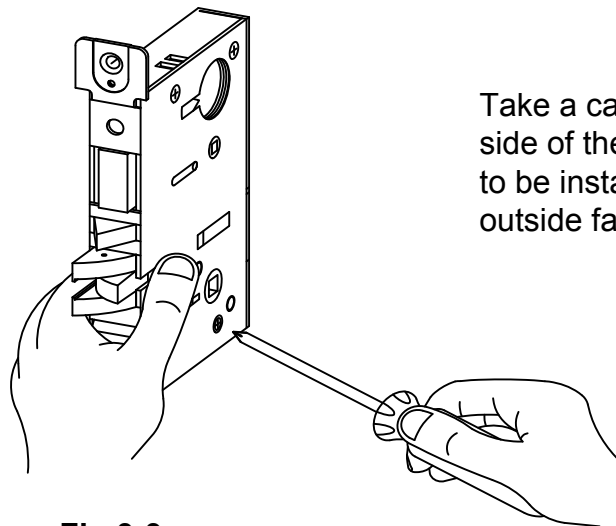
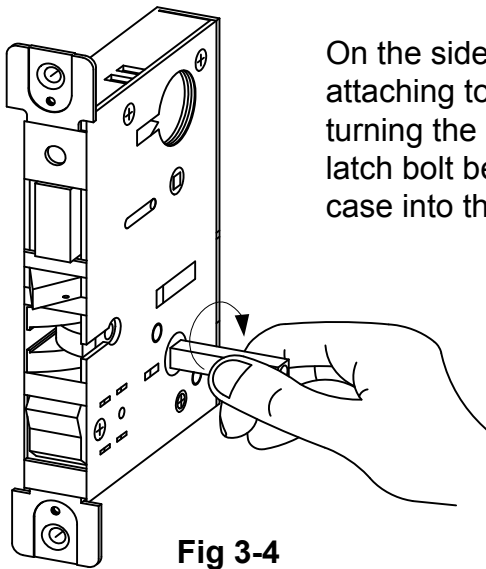

Fig 3-3

Check that the hub of the lock is seated in the correct position before proceeding to the next step. Insert spindle into hub of the lock case and turn until latch bolt is retracted (Fig 3-4).



On the side of the lock case that is attaching to the trim, check that turning the spindle retracts the latch bolt before installing the lock case into the mortise cut-out.

Fig 3-4

4. INSTALL LOCK CASE IN DOOR

Insert lock case into mortise cut-out and fasten to door with two flat head screws (Fig 4)

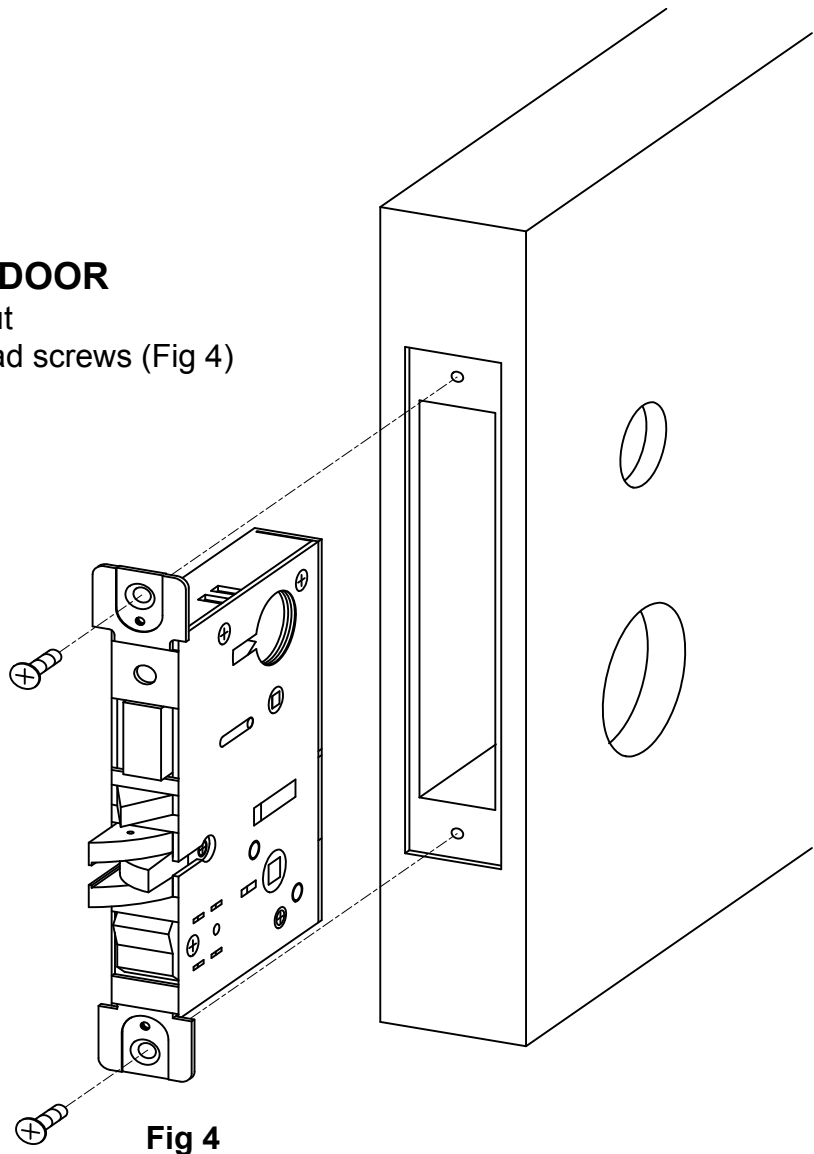

Fig 4

5. INSTALL DEVICE:

1. Remove chassis cover from chassis assembly and end cap from end cap bracket.
2. Insert the Pull Finger beneath device chassis into the "A" hole in lock case (Fig 5-1) then mount device horizontally to the drilled position with 6 supplied screws to door (Fig 5-2).
3. Place end cap bracket as a template, mark and drill holes then screw it to secure the device.
4. Check device for correct operation:
 - A. Depress Push Bar, latch bolt should retract to flush position.
 - B. Release Push Bar, latch bolt is fully extended.
5. Tighten all screws and bolts.

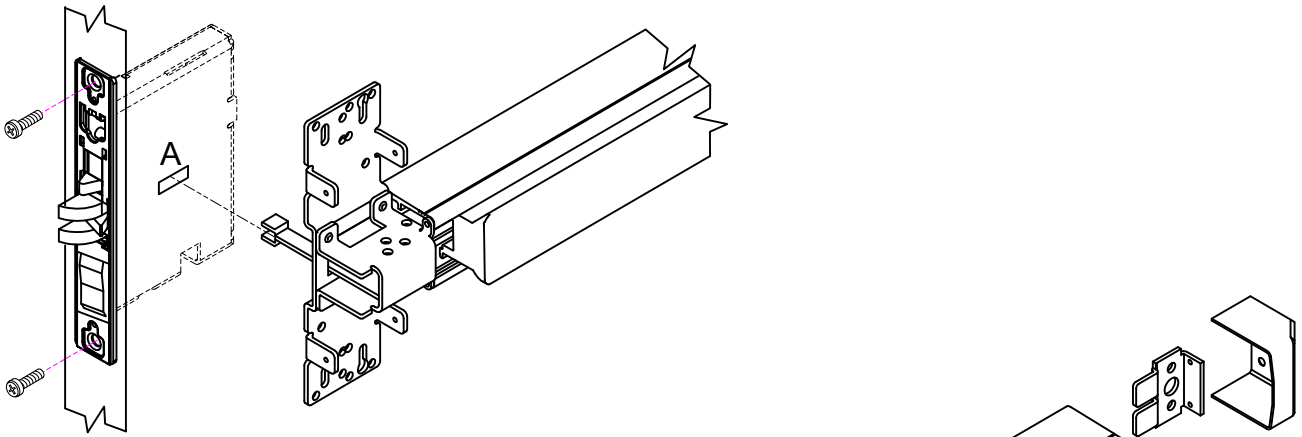

Fig 5-1

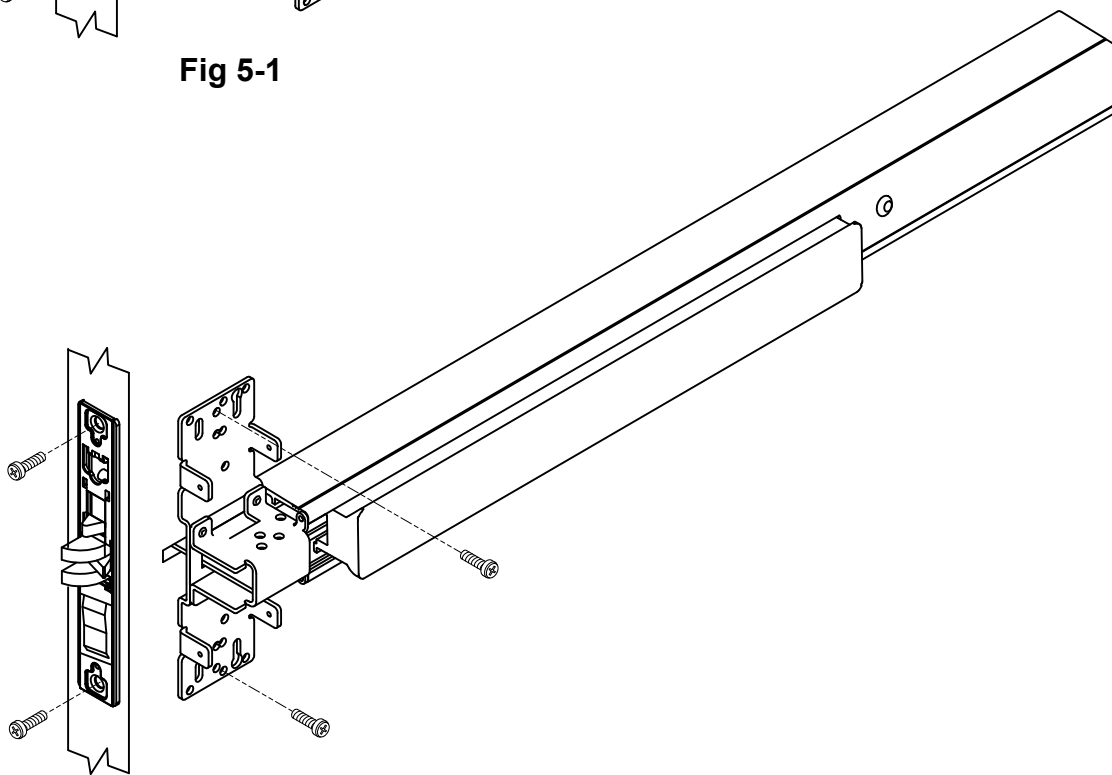

Fig 5-2

6. INSTALL OUTSIDE TRIM AND CYLINDER

NOTE: Follow this step only if SDC's Entry Lever trim is used. If other trim is used with this device, please refer to the original manufacturers instructions.

1. Check the direction of the outside lever to be installed, then place the reversible spring cage into ferrules with the arrow pointing in the direction of the lever rotation and fasten with screws supplied (Fig 6-1).
2. Insert spindle into hub of spring cage on outside trim (Fig 6-2).

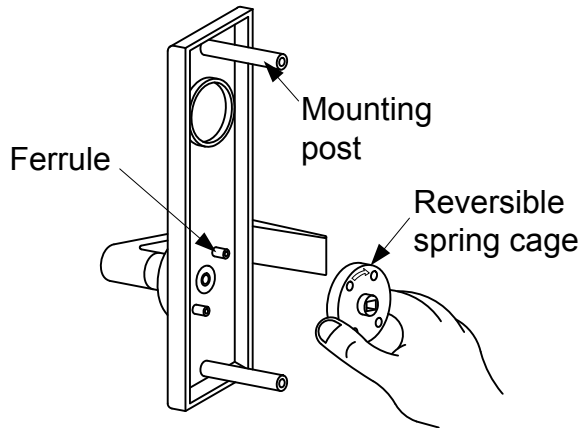

Fig 6-1

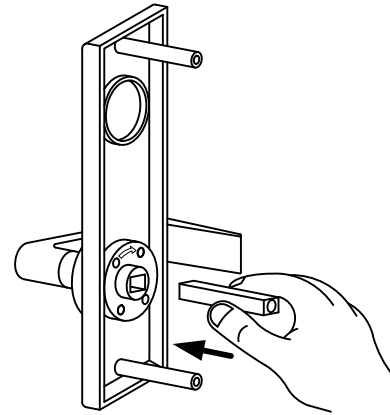

Fig 6-2

3. Install outside trim with mounting posts through door and position spindle into hub of lock case (Fig 6-3)
4. Mount two long screws through device chassis into the mounting posts of outside trim.
5. Screw cylinder into threaded hole of lock case (Fig 6-4).
6. Tighten the set screw counter-clockwise against cylinder as shown.

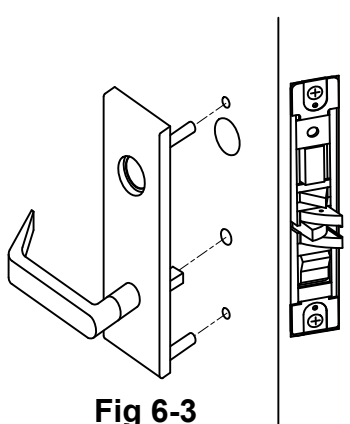

Fig 6-3

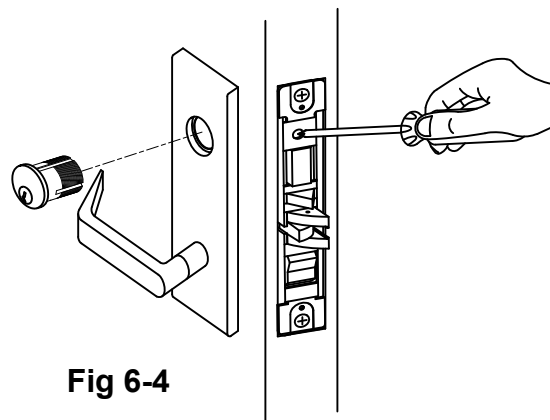

Fig 6-4

7. Install face plate onto lock case front and fasten with supplied screws (Fig 6-5).

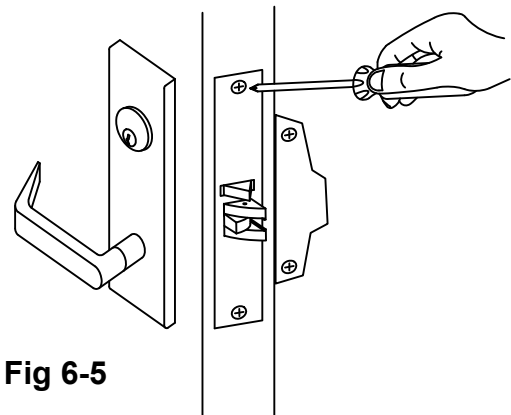

Fig 6-5

7. TEST OPERATION AND INSTALL COVERS

1. Test push bar and dogging operation before installing covers:
 - A. *NO TRIM*: Latch bolt is retracted by depressing push bar inside.
 - B. *WITH TRIM*: Latch bolt is retracted by push bar inside, and;
 - a) When outside key locks the lever/knob, the lever/knob will be made inoperative.
 - b) When outside key unlocks the lever/knob, the lever/knob can retract the latch bolt.
 - C. *DOGGING*: See dogging description and chart below.
2. Check and secure latch bolt engagement. Adjust strike if necessary.
3. Install chassis cover on chassis assembly.
4. Install end cap on end cap bracket.

DOOR HANDING

Use this diagram to determine the handing of the door.

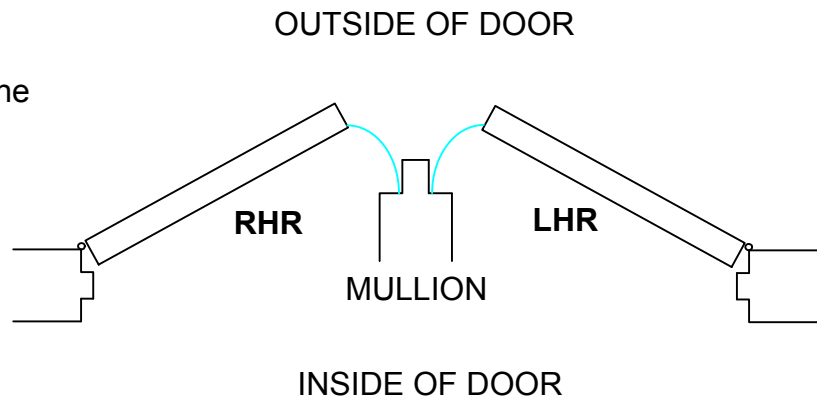

NOTE:

For extending the life of this device, it is recommended utilizing the Dogging feature during high traffic periods of the day (Panic device only).

Dogging:

Depress push bar,
insert dogging wrench
and turn clockwise 15°.

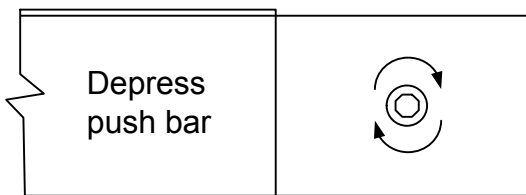

The push bar will remain pressed and the latches will keep retracted.

Release Dogging:

Depress push bar,
insert dogging wrench
and turn counter-clockwise 15°.

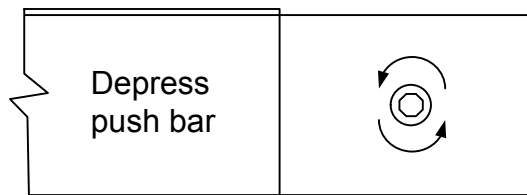

The push bar will return to the up position and the latches will project to lock the door.

Dogging wrench
(Allen key)

