

# Installation Instructions

**SARGENT**

**ASSA ABLOY**

## L980S Lockable Non Fire Rated Mullion

- 1 Install exit devices according to instructions included with the exit devices before installing mullion. This will ensure the correct positioning of the mullion between the center cases.
- 2 Center bottom retainer between doors and fasten in place with screws provided.
- 3 Center top retainer between doors and fasten in place with screws provided.
- 4 Determine the length of the mullion and cut off the bottom end.  
(Length of Mullion = dim "x" - 3/4") (1/8" clearance at top)
- 5 Place mullion assembly into bottom retainer and slide top of the mullion into the top retainer until it latches.

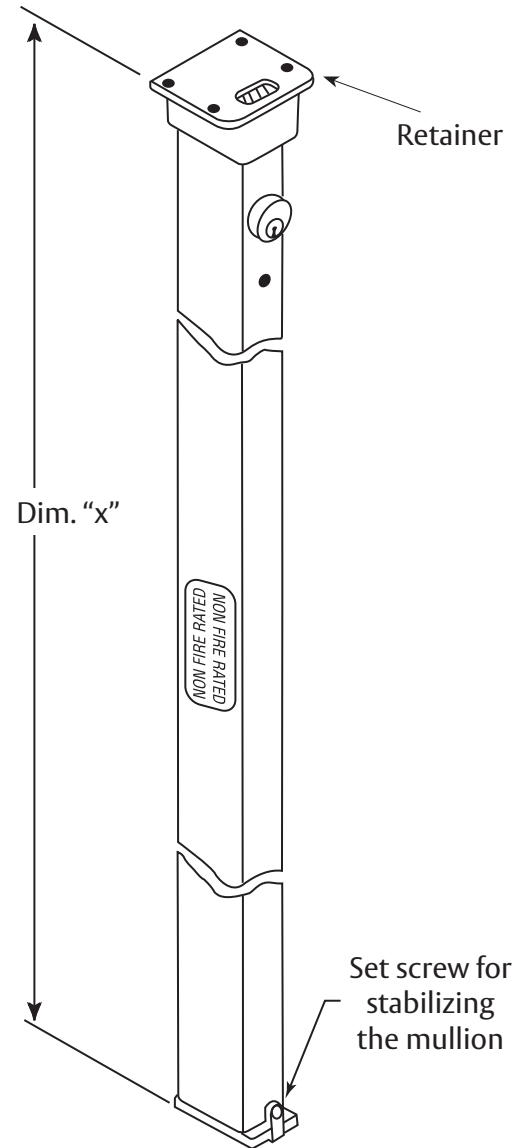
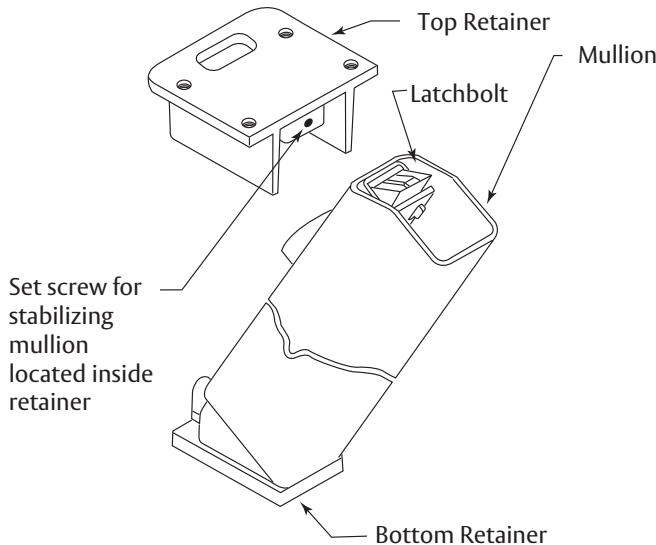

- 6 To eliminate any rattle remove mullion using the key and adjust set screws in top and bottom retainers.  
**Do not over tighten set screws.**
- 7 Position strike on center line of latch bolt per exit instructions, drill and tap mullion.
- 8 Attach strike with (2) screws through slotted holes. Adjust for proper position and tighten screws. Drill and tap the (2) center holes in mullion and install screws securely (both sides).

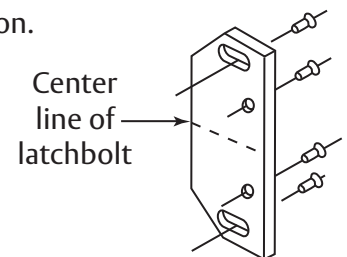

Pictures shown are for illustration purpose only. Actual product may vary.

### Cylinder Installation

- 1** Depress latchbolt and hold fully depressed while screwing cylinder into chassis until it bottoms out.
- 2** Unscrew until keyway is at the bottom and the name on the cylinder is straight.
- 3** Tighten locking screw so that the end of the locking arm mates with slot in the cylinder and tighten securely.

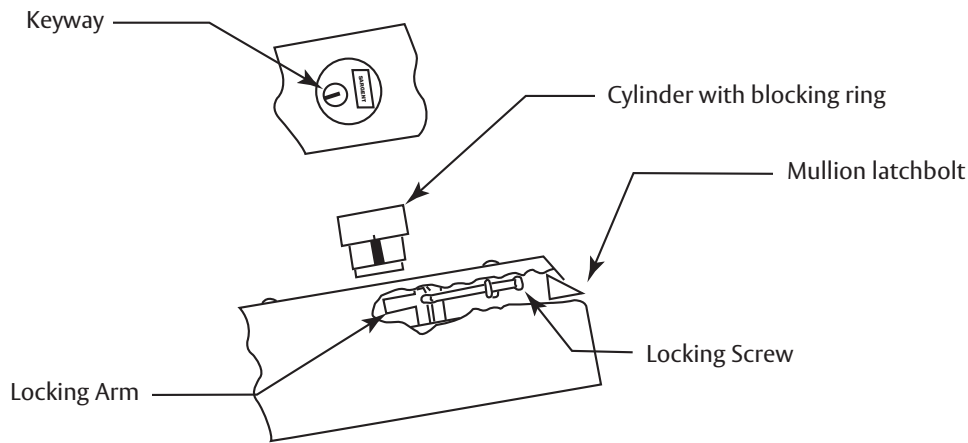

### WARNING

This product can expose you to lead which is known to the state of California to cause cancer and birth defects or other reproductive harm. For more information go to [www.P65warnings.ca.gov](http://www.P65warnings.ca.gov).

Experience a safer  
and more open world