



ELECTRIC EXIT DEVICE OPERATING INSTRUCTIONS MOTOR DRIVE ELECTRIC LATCH RETRACTION

1550-MDJ JACKSON 20 SERIES

PROVIDES SIMULTANEOUS ELECTRIC LATCH RETRACTION AND DOGGING (TOUCH BAR DEPRESSED)

Electrical Input Requirements:

Filtered and Regulated Power Supply
Voltage: 24VDC \pm 10%
Current: 1A MAX Inrush, 400mA MAX Holding
Non-polarized Leads

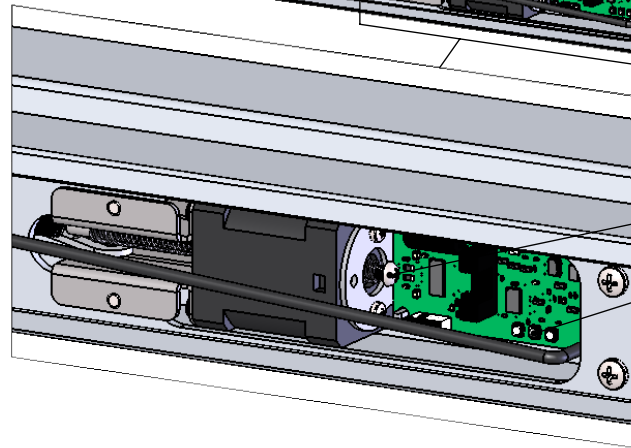
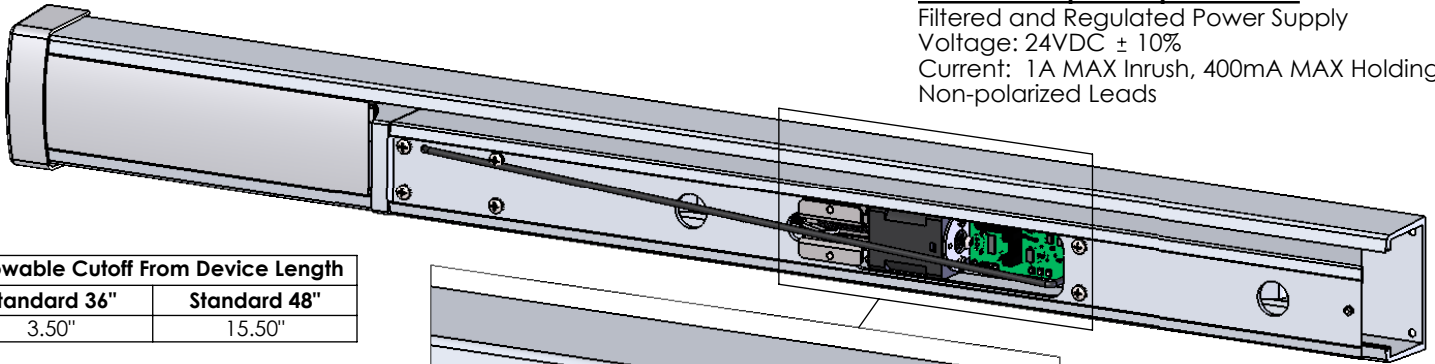

Allowable Cutoff From Device Length

Standard 36"	Standard 48"
3.50"	15.50"

2-Conductor Wire Run

Distance	Wire Gauge
70'	22
110'	20
180'	18
280'	16
450'	14
720'	12

Motor Drive Electric Latch Retraction Adjustment:

1. Verify the device is properly adjusted for mechanical operation. Electric operation should not exceed the mechanical operation or there will be a high risk of damage to the device. **We suggest setting the latch retraction under electric operation at 1/16" less than the latch retraction under mechanical operation.**
2. Locate the adjustment screw in the rear of the motor assembly. Rotate the adjustment screw clockwise to increase the latch retraction or counterclockwise to decrease the latch retraction.

Onboard Indicator Light Assignments:

Maintain input power to the exit device and check the onboard indicator lights.

Remove input power before attempting a solution.

Green (Power)	Yellow (Sensor)	Red (Error)	Indication	Possible Solution
Off	Off	Off	No Power.	Connect the wiring between the power supply and the exit device.
On	On	Off	Normal Operation. The touch bar is retracted to the dogged position and dogged; the latch is retracted by default. The device is allowed 2 attempts.	
On	Off	On	Error in operation. The touch bar did not retract to the dogged position within 2 attempts.	Rotate the adjustment screw counterclockwise to decrease the latch retraction.
On	On	On	Error in operation. Without power being removed, the touch bar went from being dogged to unintentionally being extended, and then the touch bar did not retract to the dogged position within 2 attempts.	Clear the jam condition manually.
On	Blink	On	Error in operation. The touch bar did not extend from the dogged position when the power was last removed. The device will not attempt a retraction.	Clear the jam condition manually.
On	Simultaneous Blink		Error in operation. The input voltage dropped below the specification during operation.	Decrease the wire run or increase the wire gauge.
On	Alternating Blink		Error in operation. An electronics fault was detected.	An electronics replacement is required.