



Surface mounted closer

4040XP Series

Overview

The 4040XP is LCN's most durable and flexible heavy duty closer designed for institutional and other demanding high traffic applications.



Cylinder

4040XP-3071

Cast iron cylinder assembly

Handing

Non-handed

Sizing

Adjustable Spring Size 1-6
includes patented Green Dial

Available cylinder options

DEL	Delayed action cylinder
-----	-------------------------

Mounting

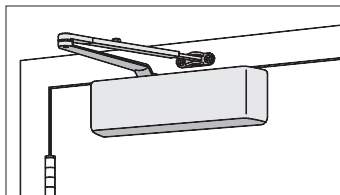

Hinge (pull side)

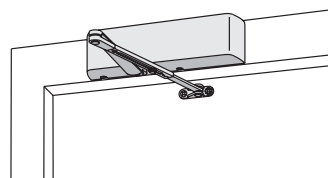

Top jamb (push side)

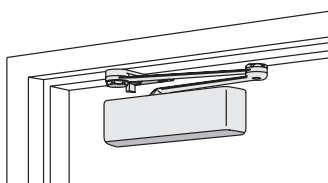

Parallel arm (push side)



Finishes

Powder coat finishes

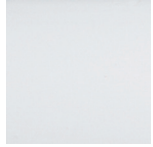

689
Aluminum



690
Statuary Bronze



691
Light Bronze



693
Black



695
Dark Bronze



696
Brass

150+ additional custom colors available using the RAL numbering system

Metal plated finishes



632
Bright Brass



633
Satin Brass



639
Satin Bronze

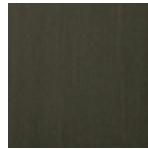

643e
Satin Bronze,
Blackened



646
Satin Nickel



651
Bright Chrome



652
Satin Chrome

Available finish options

MTLPC	Brite metallic: Custom powder coat finish, which resembles that of US26 or US26D plated finish.
SRI	For installations where a higher level of protection against weather conditions, or the effects of a potentially corrosive atmosphere is required, LCN offers a special rust inhibiting (SRI) process. Ferrous metal components receive an SRI pretreatment and a standard powder coat finish of your choice, or a custom powder coat finish for a nominal additional cost. Closers treated with the SRI process exceed the 100 hour protection level available with standard LCN powder coated finishes.

Covers

Standard cover

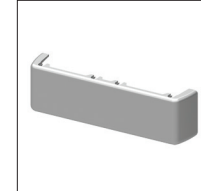

4040XP-72

Plastic cover

- Non-handed
- Includes 4040XP-54 snap-on cover clip

Optional covers

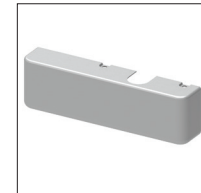

4040XP-72MC

Metal cover

- Handed
- Required for plated finishes and custom powder coat finishes
- Optional

Arms



4040XP-3077

Regular arm

- Non-handed
- Mounts pull side or top jamb with shallow reveal P4041 closer includes PA SHOE, 4040XP-62PA required for parallel arm mounting



4040XP-3077L

Long arm

- Non-handed
- Includes LONG ROD AND SHOE, 4040XP-79LR for top jamb mount
- Optional



4040XP-3077ELR

Extra long arm

- Non-handed
- Includes EXTRA LONG ROD AND SHOE, 4040XP-79ELR for top jamb mount with deep reveal
- Optional



4040XP-3049

Hold-open arm

- Non-handed
- Mounts pull side or top jamb with shallow reveal, hold-open adjustable shoe
- 4040XP closer includes 4040XP-62PA shoe required for parallel arm mounting
- Optional



4040XP-3049L

Long hold-open arm

- Non-handed
- Includes LONG HEAD AND TUBE, 4040XP-3048L for top jamb mount
- Optional



4040XP-3077EDA

Extra duty arm

- Non-handed
- Features forged, solid steel main and forearm for potentially abusive installations
- Optional



4040XP-3049EDA

Hold-open extra duty arm

- Handed
- Parallel arm features forged, solid steel main and forearm for potentially abusive installations
- Hold-open function is adjusted at the shoe
- Optional



4040XP-3077EDA/62G

Extra duty arm with 62G

- Non-handed
- Features forged, solid steel main and forearm for potentially abusive installations
- 62G shoe provides additional blade stop clearance
- Optional



4040XP-3049EDA/62G

Hold-open extra duty arm with 62G

- Handed
- Features forged, solid steel main and forearm for potentially abusive installations
- 62G shoe provides additional blade stop clearance. Hold-open function is adjusted at the shoe
- Optional



4040XP-3077CNS

Cush-N-Stop® Arm

- Non-handed
- Features solid forged steel main arm and forearm with stop in soffit shoe.
- Optional



4040XP-3049CNS

HCUSH arm

- Non-handed
- Hold-open function with templated stop/hold-open points
- Handle controls hold-open function
- Optional



4040XP-3077SCNS

Spring CUSH arm

- Non-handed
- For abusive applications features solid forged steel main arm and forearm with spring loaded stop in the soffit shoe
- Optional

Arms



4040XP-3049SCNS

Spring HCUSH arm

- Non-handed
- For abusive applications features solid forged steel main arm and forearm with spring loaded stop in the soffit shoe
- Handle controls hold-open function
- Optional

Installation accessories

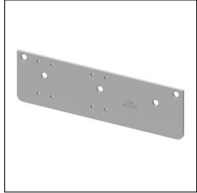

**4040XP-18
Plate**

- Required for hinge side mount where top rail is less than 3-3/4" (95 mm)
- Requires minimum 2" (51 mm) minimum top rail

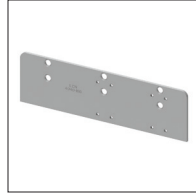

**4040XP-18G
Plate**

- Locates top jamb mounted closer flush with top of head frame face in flush ceiling condition
- Requires 1-3/4" (44 mm) minimum head frame

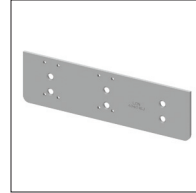

**4040XP-18TJ
Plate**

- Centers top jamb mounted closer vertically on head frame where face is less than 3-1/2" (89 mm). Plate requires 1-3/4" (44 mm) minimum head frame

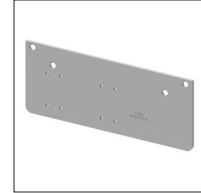

**4040XP-18PA
Plate**

- Required for parallel arm mounting where top rail is less than 5-1/2" (140 mm), measured from the stop
- Requires 2" (51 mm) minimum top rail



**4040XP-62PA
PA shoe**

- Required for parallel arm mounting

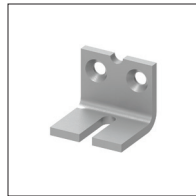

**4040XP-30
CUSH shoe support**

- Provides anchorage for fifth screw used with CUSH arms, where reveal is less than 3-1/16" (78 mm)
- Optional



**4040XP-61
Blade stop spacer**

- Required to lower parallel arm shoe to clear 1/2" (13 mm) blade stop
- Optional

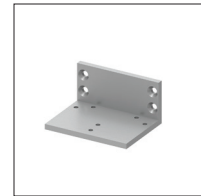

**4040XP-419
PA flush panel adapter**

- Provides horizontal mounting surface for parallel arm shoe on single rabbeted or flush frame
- Optional

Installation accessories

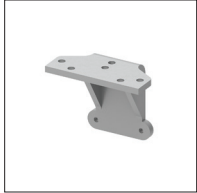

4040XP-62A

Auxiliary shoe

- Requires a top rail of 7" (178 mm)
- Shoe replaces -62PA for parallel arm mounting of regular arm with overhead holder/stop
- Optional



4040XP-54

Snap-on cover clip

- Used to secure 4040XP-72 plastic cover to cylinder body

Fasteners

Self-reaming and tapping screws included standard

Fastener pack options

TBSRT	TB ¹ with self-reaming and tapping screws
WMS	Wood and machine screw
TBWMS	TB ¹ , wood and machine screw
TORX	TORX machine screw
TBTORX	TB ¹ and TORX machine screw

¹ Specify door thickness if other than 1-3/4"

Dimensions and mounting

Hinge (pull) side mounting

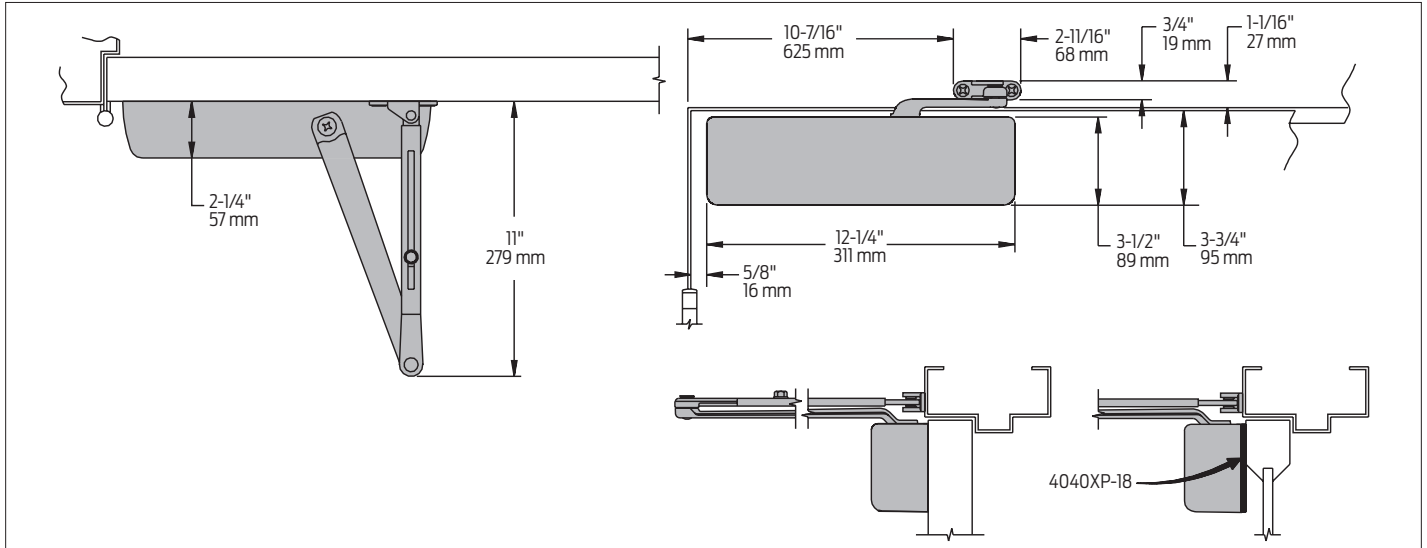

Top jamb (push side) mounting

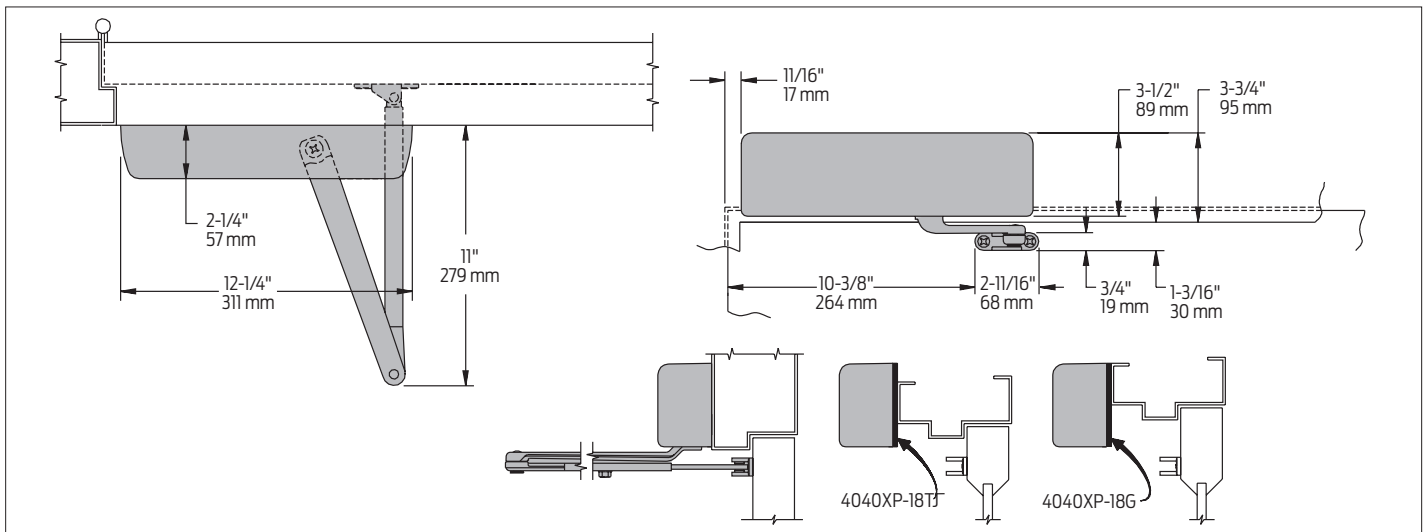

Dimensions and mounting

Parallel arm (push side) mounting

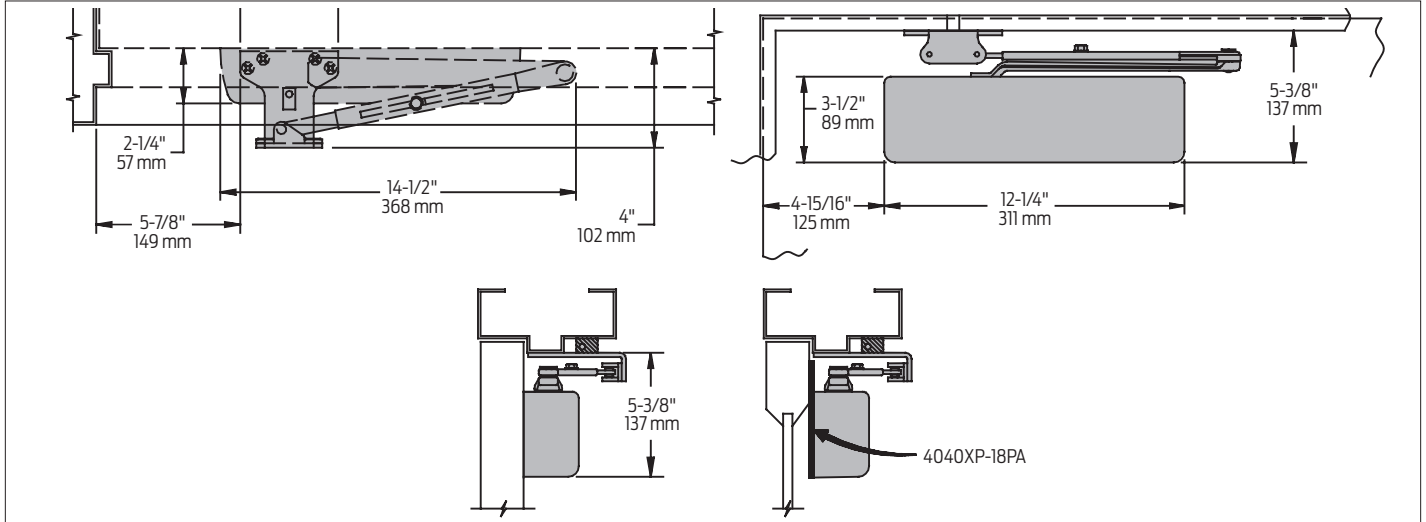

EDA mount

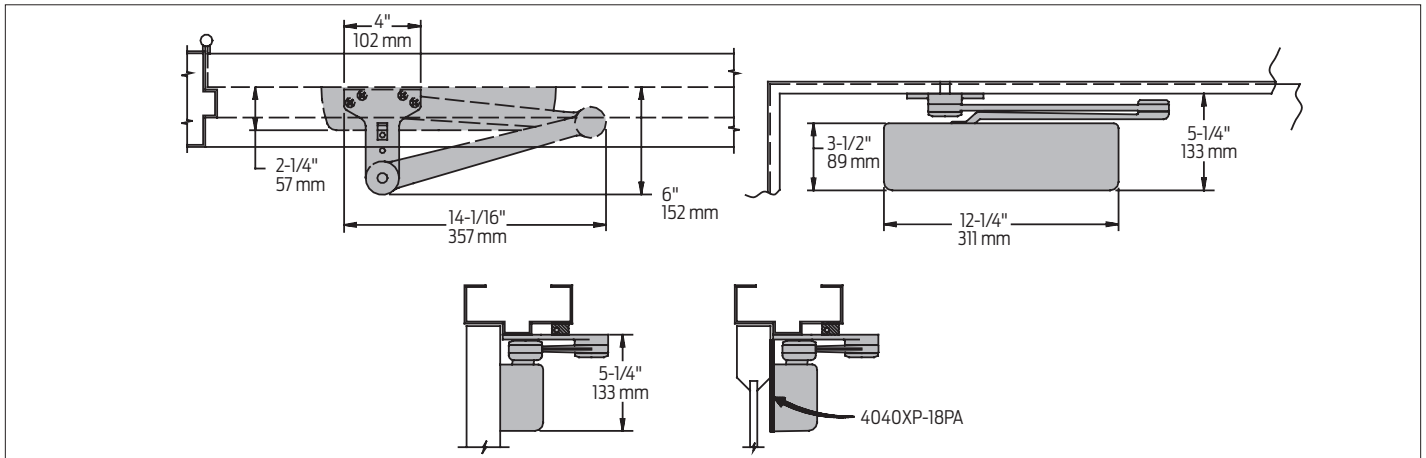

CUSH mount

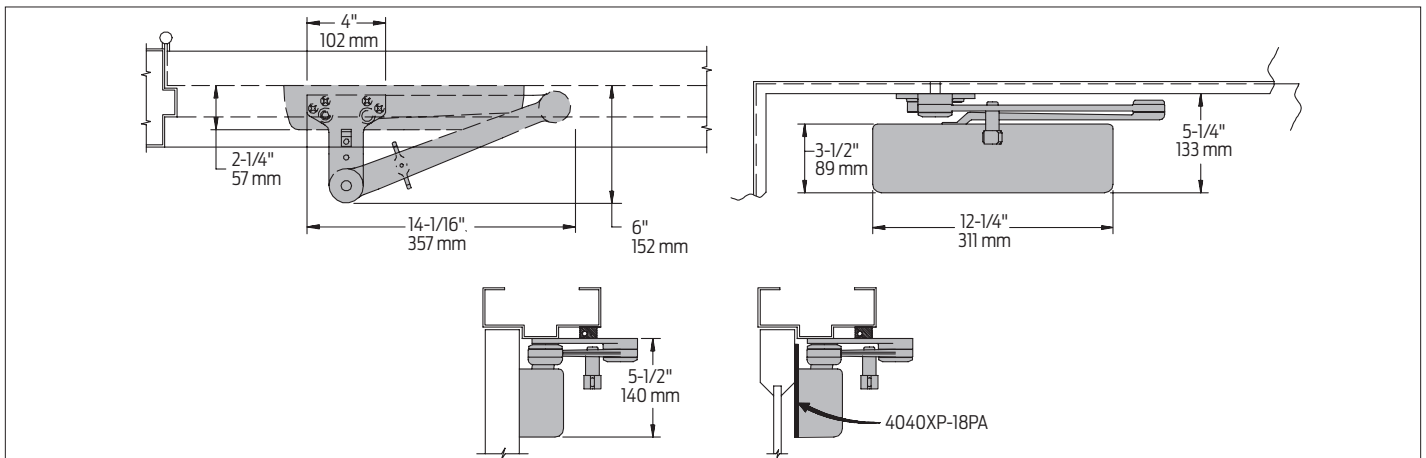

Specifications

Accessibility	Available with less than 5.0 lbs. opening force on 36" door
Certifications/ approvals	<ul style="list-style-type: none"> ■ Grade 1 - ANSI A156.4 ■ UL 10C ■ Meets BAA - Buy American Act
Degree of operation	<p>Hinge (pull) side</p> <p>Max opening: 120°</p> <p>Hold open: 90-120°</p> <p>Top jamb (push side) mount</p> <p>Max opening: 120°</p> <p>Hold open: 85-120°</p> <p>Parallel arm with 62PA</p> <p>Max opening: 180°</p> <p>Hold open: 180°</p> <p>EDA</p> <p>Max opening: 180°</p> <p>Hold open: 180°</p> <p>Cush</p> <p>Max opening: 110°</p> <p>Hold open: 110°</p>
Environmental conditions	<ul style="list-style-type: none"> ■ Approved for interior use ■ Approved for exterior use (SRI coated only) ■ LCN's standard all weather fluid performs to temperature ranges from 120°F (49°C) to -30°F (-35°C) ■ LCN's powder coat finish surpasses 100 hours of salt spray which is over four times the ANSI standard for corrosion resistance.
Warranty	30 years
Standard features	<ul style="list-style-type: none"> ■ Cast iron body ■ Full complement bearing ■ 1-1/2" diameter piston ■ 3/4" diameter double heat treated pinion journal