

# SDC Security Door Controls

801 Avenida Acaso, Camarillo, Ca. 93012 • (805) 494-0622 •  
www.sdcsecurity.com • E-mail: service@sdsecurity.com

## INSTALLATION INSTRUCTIONS LR100ARK-EM ADAMS RITE ELECTRIC LATCH RETRACTION DEVICE KIT VERTICAL ROD EXIT DEVICE MODELS: 3100, 3600, 8100, 8200, 8500 & 8600

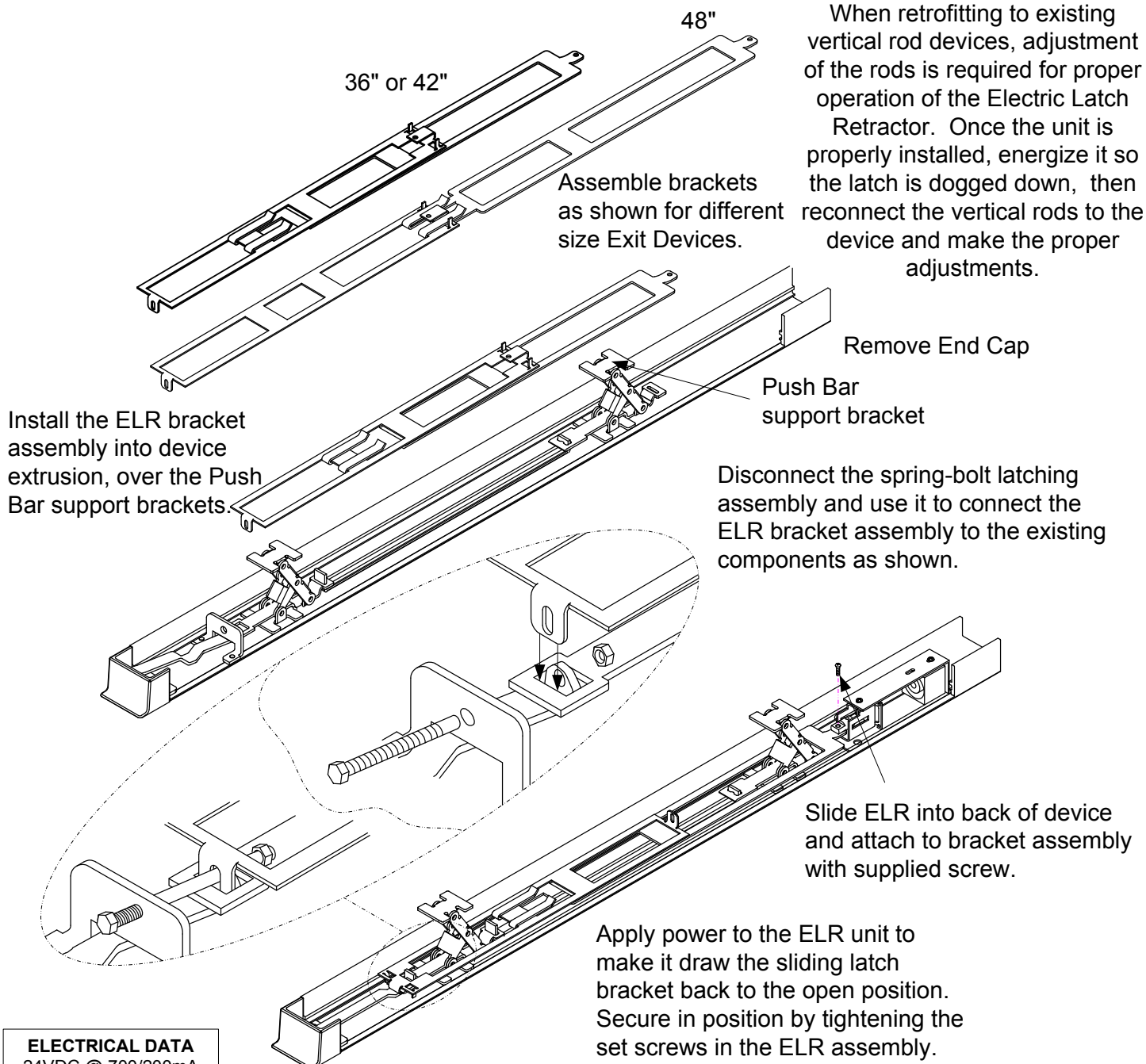

When retrofitting to existing vertical rod devices, adjustment of the rods is required for proper operation of the Electric Latch Retractor. Once the unit is properly installed, energize it so the latch is dogged down, then reconnect the vertical rods to the device and make the proper adjustments.

Install the ELR bracket assembly into device extrusion, over the Push Bar support brackets.

Assemble brackets as shown for different size Exit Devices.

Remove End Cap

Push Bar support bracket

Disconnect the spring-bolt latching assembly and use it to connect the ELR bracket assembly to the existing components as shown.

Slide ELR into back of device and attach to bracket assembly with supplied screw.

Apply power to the ELR unit to make it draw the sliding latch bracket back to the open position. Secure in position by tightening the set screws in the ELR assembly.

**ELECTRICAL DATA**  
24VDC @ 700/200mA  
RED (+) BLK (-)  
PATENT #8,851,530

Any suggestions or comments to this instruction or product are welcome. Please contact us through our website or email engineer@sdsecurity.com

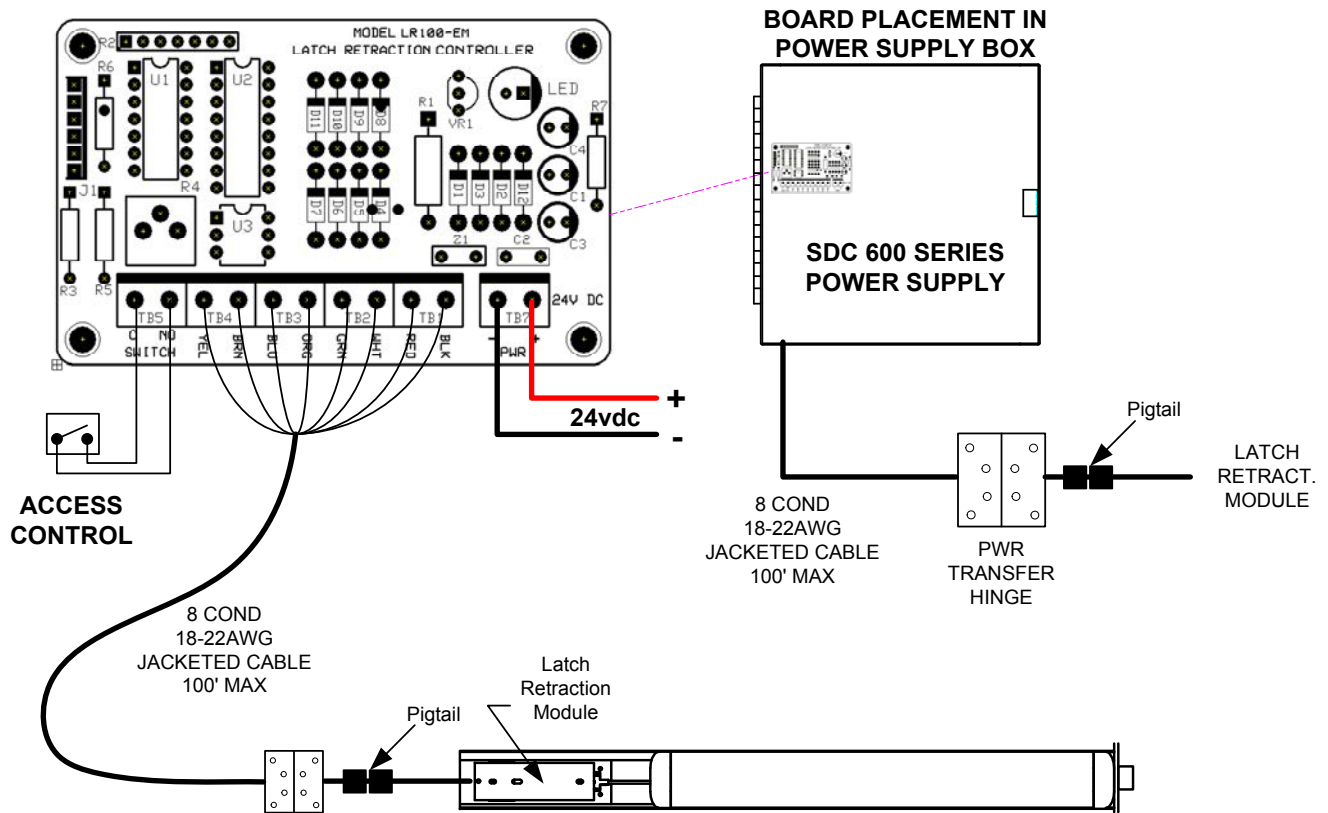

**Retrofit Installation Note:** 42" or 48" exit devices that have been modified to fit a 36" or smaller opening, may not have the required space to fit the standard E. L. R. assembly. Always verify the distance from the end of the touchpad to the end rail, and if necessary, consult with the factory for appropriate selection.