

# SDC Security Door Controls

801 Avenida Acaso, Camarillo, CA 93012

• (805) 494-0622 • [www.sdcsecurity.com](http://www.sdcsecurity.com) •

E-mail: [service@sdsecurity.com](mailto:service@sdsecurity.com)

## INSTALLATION INSTRUCTIONS LR100AREXK ADAMS RITE ELECTRIC LATCH RETRACTION DEVICE KIT RIM/VERTICAL ROD DEVICES

### RIM DEVICE MODELS: EX88 & EX89

#### STEP 1

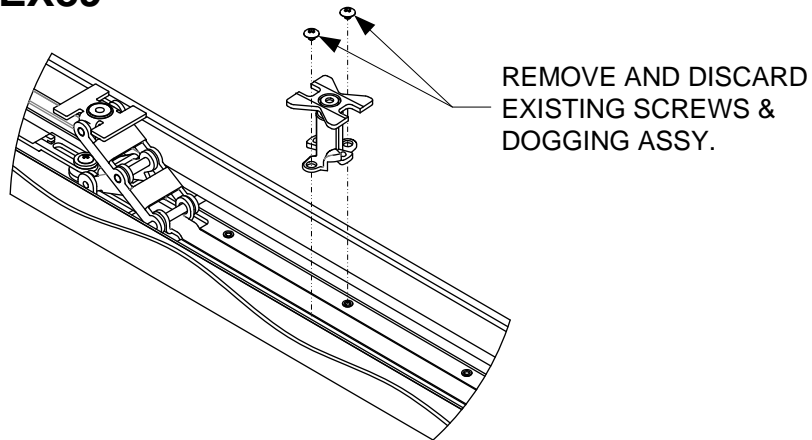

#### STEP 2

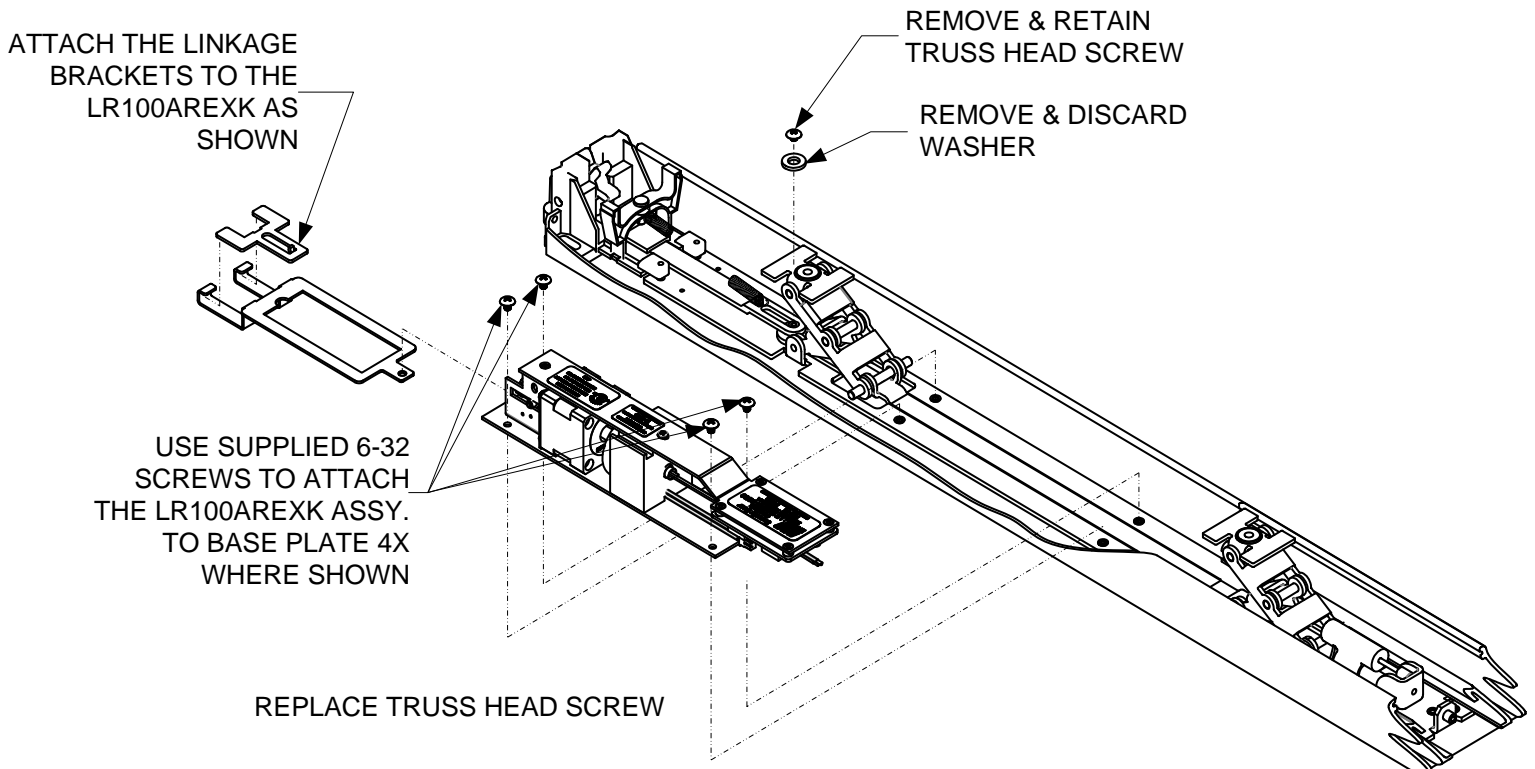

Any suggestions or comments to this instruction or product are welcome. Please contact us through our website or email [engineer@sdsecurity.com](mailto:engineer@sdsecurity.com)

# VERTICAL ROD DEVICE MODEL: EX76

## STEP 1

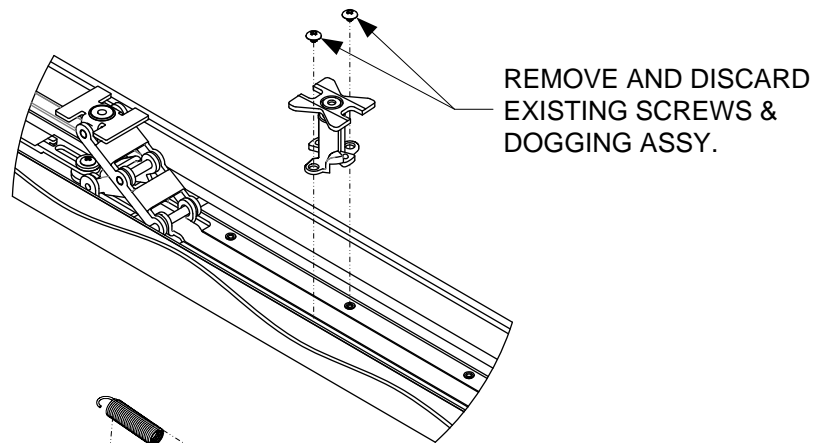

## STEP 2

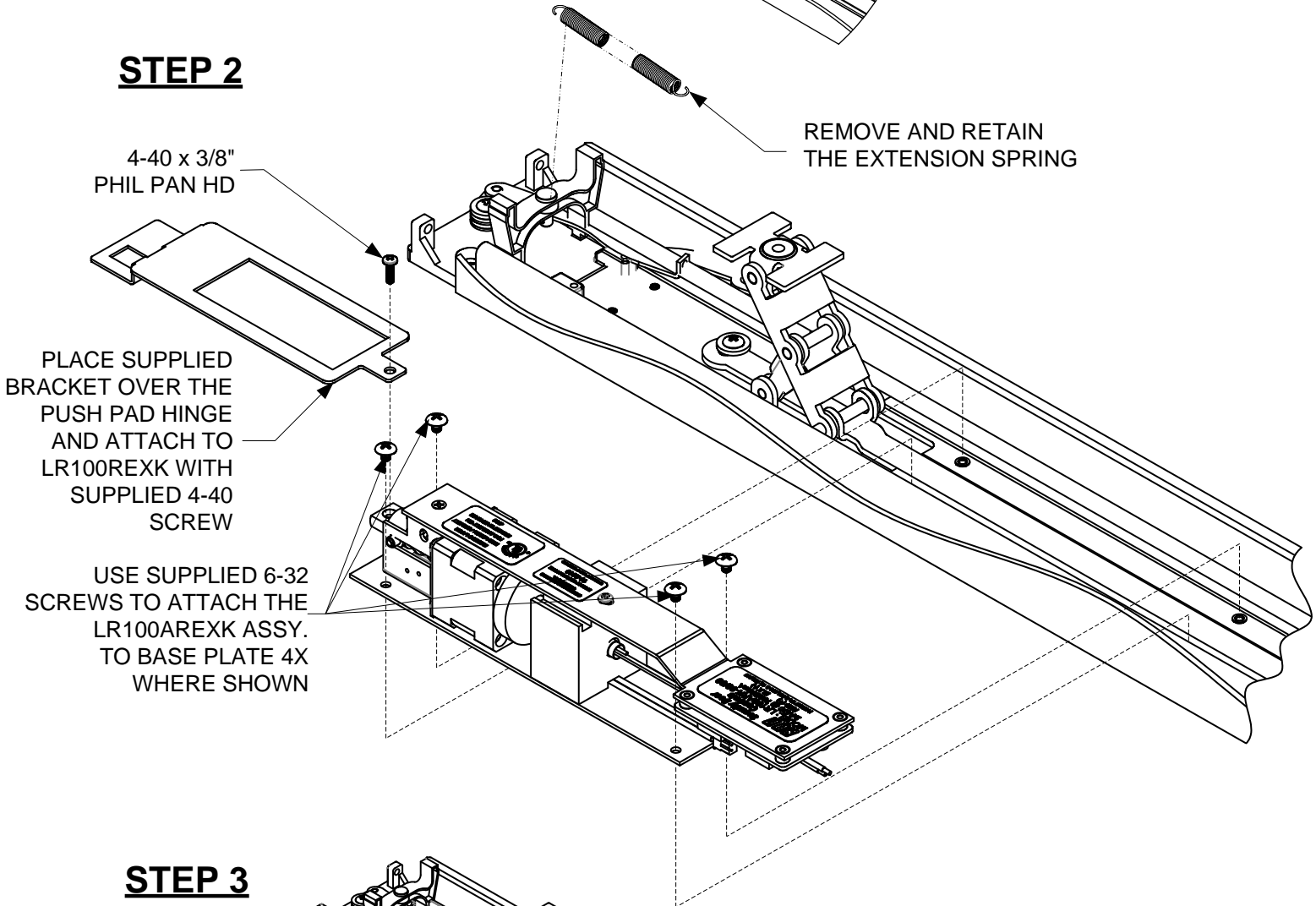

## STEP 3

