

ALUMA-GUARD INSTRUCTIONS

STEP 1.

Center Aluma-Guard over lock cylinder keyway as illustrated and mark top and bottom holes with a pencil.

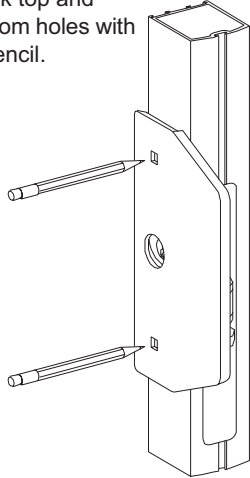

STEP 2.

Center punch the pencil marks to create drill starting points. Drill two 17/64" holes as follows:

a. Drill the top hole straight through the door channel to the other side.

b. Drill the bottom hole only through the surface of the door channel. **DO NOT DRILL INTO THE LOCK.**

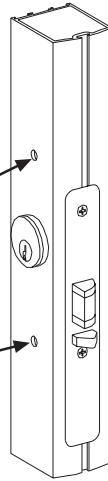

STEP 3.

Place the anchor pad centered on the bottom drilled hole as illustrated and mark the two side holes with a pencil.

a. Center punch and drill the two holes with a 13/64" drill only through the surface of the door channel. **DO NOT DRILL INTO THE LOCK.**

b. Install the anchor pad with two #14 sheet metal screws as illustrated. Leave the center hole open.

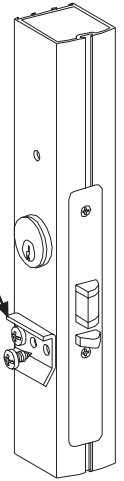

STEP 4.

1. Assemble the 5/8" Carriage Bolt to Aluma-Guard with the Washer & Plain Nut as illustrated.

2. Place bottom edge of Aluma-Guard onto lower edge of Lower Anchor Pad. See that the end of the 5/8" Carriage Bolt slips into the center hole in the Lower Anchor Pad.

3. Place Anchor Pad behind the top edge of the Aluma-Guard as illustrated and install the 2-1/2" Carriage Bolt through the Aluma-Guard and Anchor Pad and into the door channel.

4. Secure the 2-1/2" Carriage Bolt with the Washer & Acorn Nut as illustrated.

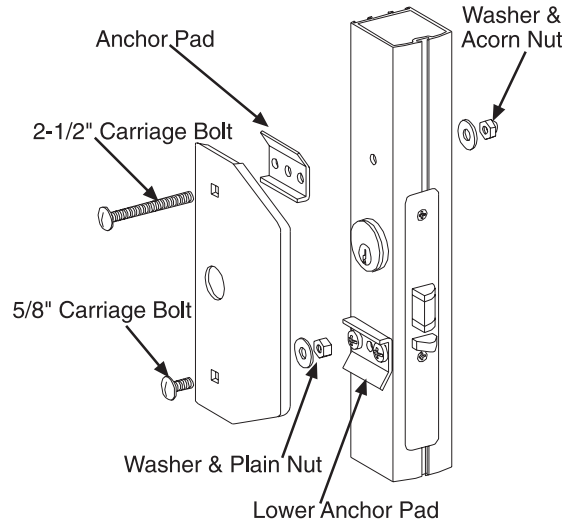

STEP 5. (optional)

You may install one, two or three Frame Pads as illustrated to help prevent door frame separation.

1. Determine the proper location to mount the Frame Pads and drill two 9/64" mounting holes. Install the Frame Pads with the two sheet metal screws provided.

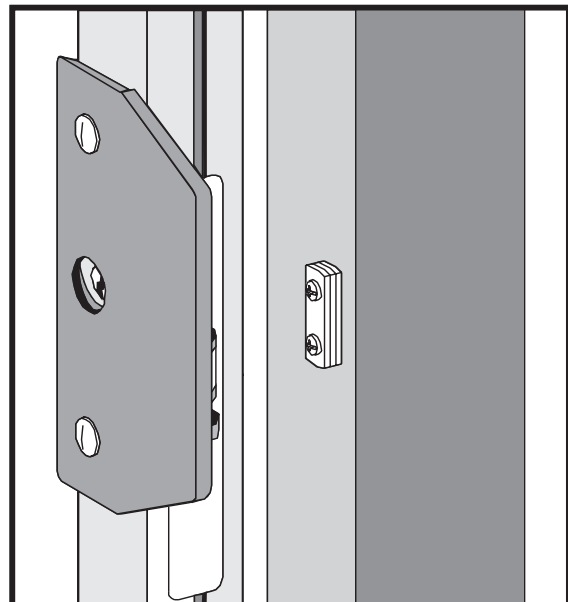
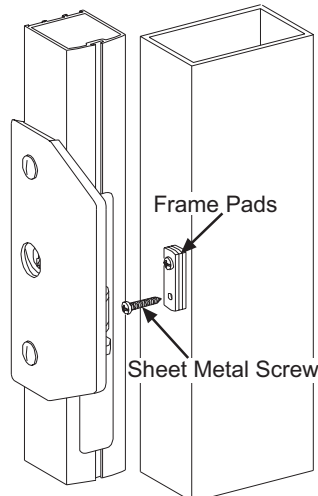

ALUMA-GUARD

Major
MANUFACTURING, INC.

ALUMA-GUARD INSTALLATION

• (714) 772-5202 • FAX (714) 772-2302