

Sportsguard™

Flooring Transitions



4985 East Raines Road • Memphis, TN 38118 • Phone: (800) 647-7874 • Fax: (800) 255-7874 • www.ngp.com

Transition Product Index:

Index	Page
ADA Compliant Interlocking Reducers	SG14
Aluminum Cover Plates	SG8
Architectural Bronze 1/4" Saddle	SG12
Architectural Bronze 1/2" Saddle	SG12
Architectural Bronze Custom	SG13
Custom Fabricated	SG9
Edge Components and Plates.	SG10-SG11
Extended Width	SG6
Fasteners	SG15
Half Saddle	SG8
Half Saddle and Extended Width Components	SG7
Heavy Duty	SG5
Interlocking Rubber Reducers.	SG14
Offset	SG8
Return Closed Ends	SG9
Return Closed Ends for Reducers.	SG14
Saddle	SG4
Sports Floor Assemblies.	SG9
Stainless Steel 1/4" Saddle	SG12

Rating Symbols Legend



ADA COMPLIANT Barrier Free Transitions meet the requirements of ADA Standards for Accessible Design and ICC/ANSI A117.1 Accessible and Usable Buildings and Facilities.



POSITIVE PRESSURE CERTIFIED by UL to ANSI/UL10C; complies with IBC, NFPA 80 and NFPA 252 for application to Hollow Metal fire doors rated up to 3 Hrs., and Wood Fire doors rated up to 90 minutes.



CERTIFIED by UL to CAN/ULC-S104 and ANSI/UL10B; complies with NFPA 80 and NFPA 252 for application to Hollow Metal fire doors rated up to 3 Hrs., and Wood fire doors rated up to 90 minutes.



Air Infiltration Tested to ASTM E283, Standard Test Method for Determining Rate of Air Leakage Through Exterior Windows, Curtain Walls, and Doors.



SLIP-RESISTANT 'SIA' textured surface is available on all transitions. Our process embeds and fuses bits of hot nickel and titanium into the surface of the transition. This technology originally developed for use on aircraft carrier decks is very skid resistant and will not wear off.



ANSI/BHMA CERTIFIED. Certified transitions comply with American National Standard for Transitions ANSI/BHMA A156.21 and are listed in the BHMA Certified Products Directory.



Online product listings at www.ul.com/database



Materials

Transitions are Aluminum Alloy 6063, T5 temper, unless noted.
 Cover Plates 818, 814 and 828 are Aluminum Alloy 3003, H14 hardness.
 Cover Plate 838 is Aluminum Alloy 5052, H32 hardness.

Architectural Bronze Transitions are Alloy CDA 385 (Copper Alloy No. C38500), Architectural Bronze.
 Brass Cover Plate 818BR is Alloy CDA 260 (Copper Alloy No. C26000) cold formed Cartridge Brass.

Stainless Steel Transitions and Cover Plates are Type 304; known for its excellent corrosion resistance, high tensile strength and resistance to oxidation.

Transition Finishes

				NGP Suffix:
Aluminum:	Mill Finish	ANSI/BHMA 719	US27	None
	Dark Bronze			DKB
	Polished	ANSI/BHMA 717		POL
	Powder Coated Colors – Slip Resistant	See Page L2 for details		SIA
Architectural Bronze:	Satin Finish	ANSI/BHMA 728	US4	BR
	Dark Bronze Oil Rubbed	ANSI/BHMA 722	US10B	BR-DKB
	Polished	ANSI/BHMA 721	US3	BR-POL
	Slip Resistant			BR-SIA
Stainless Steel:	Mill Finish			SS
	Brushed (#4)	ANSI/BHMA 630	US32D	SS-Brushed
	Polished	ANSI/BHMA 629	US32	SS-POL
	Slip Resistant			SS-SIA

Slip Resistant Finish

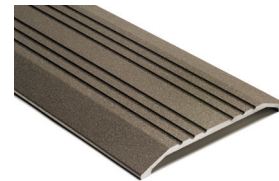

SIA (Slick It Ain't) finish is our slip resistant textured surface, available on all transitions up to 24" wide and on 818 aluminum and brass cover plates up to 10" wide.

Our SIA technology embeds bits of hot nickel and titanium into the surface of the transition using a high pressure thermo-electrostatic process. It was originally developed for use on aircraft carrier decks. SIA finish is very durable and will not wear off.

This results in a slip resistant surface that is similar to high grit sandpaper.

Aluminum and Stainless Steel SIA finish transitions are a pewter color.
 Architectural Bronze SIA finish transitions are a brass color.

Powder Coat Finish

Powder Coat finish is available on most transitions upon request. Consult factory for custom color matching.

Saddle Transitions

All transitions this page    

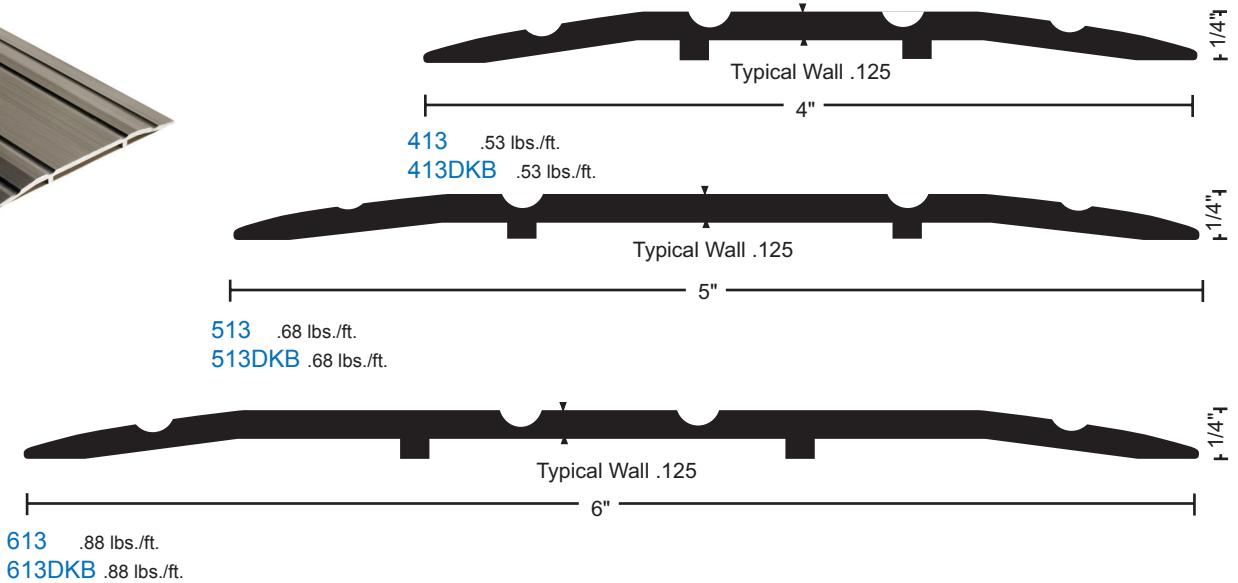
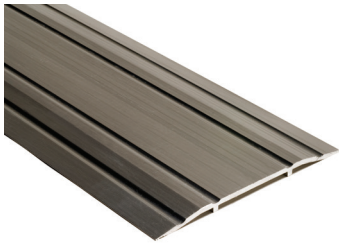

<u>Transition</u>	<u>Width</u>
413, 413DKB, 413BR	4"
513, 513DKB, 513BR	5"
613, 613DKB, 613BR	6"
713, 713DKB, 713BR	7"
813, 813DKB, 813BR	8"
913, 913DKB	9"
1013, 1013DKB	10"

Note: Flute pattern varies with width of transition

MATERIALS & FINISHES

- Aluminum mill finish standard
- DKB - Aluminum dark bronze finish
- BR - Architectural Bronze



• Optional: Slip Resistant SIA Finish

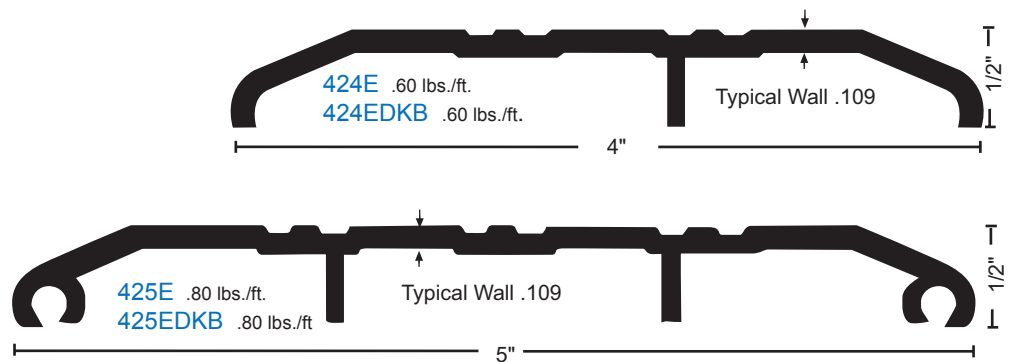
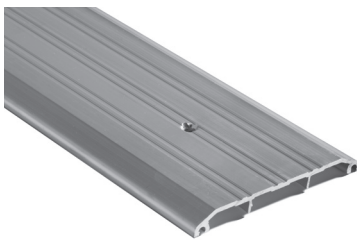

<u>Transition</u>	<u>Width</u>
425E, 425EDKB	5"
426E, 426EDKB	6"
427E, 427EDKB	7"
428E, 428EDKB	8"
429E, 429EDKB	9"
430E, 430EDKB	10"

Note: Flute pattern varies with width of transition



VINYL FOOT SEAL OPTION:
used instead of caulking to increase the weather resistance of the transition. Specify on order.

Heavy Duty Transitions

All transitions this page    **BHMA** CERTIFIED

 • Optional: Slip Resistant SIA Finish



- For use where forklift or vehicular traffic occurs
- Recommended for delivery/storage doorways where heavier loads travel
- BHMA certified to ANSI A156.21 Heavy Duty 10,000 lb. load test
- Optional "SIA" slip-resistant finish recommended in moisture prone areas

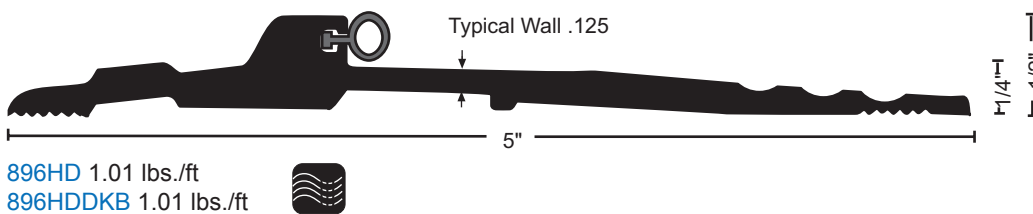
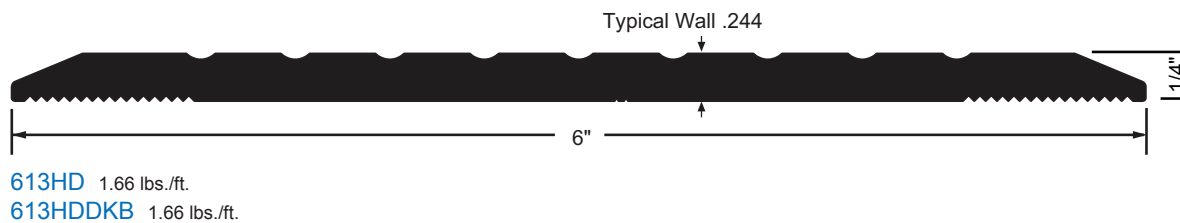
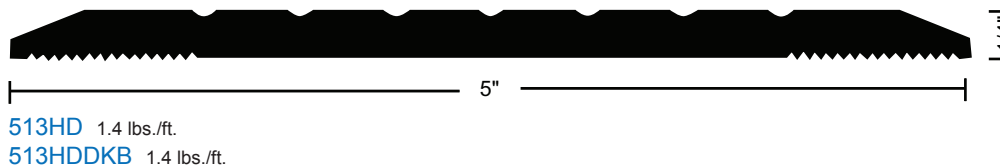
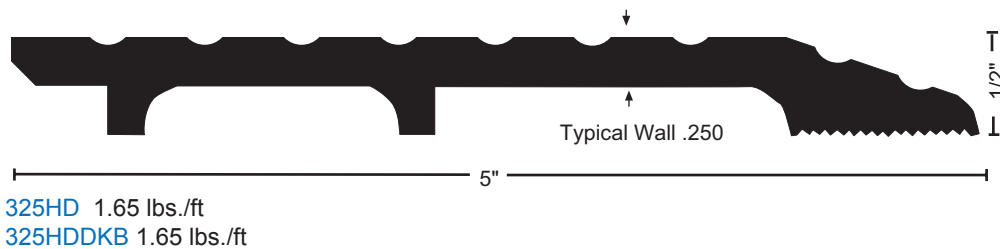
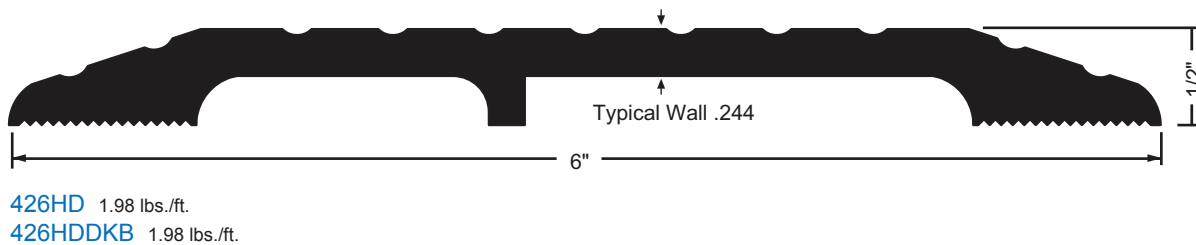
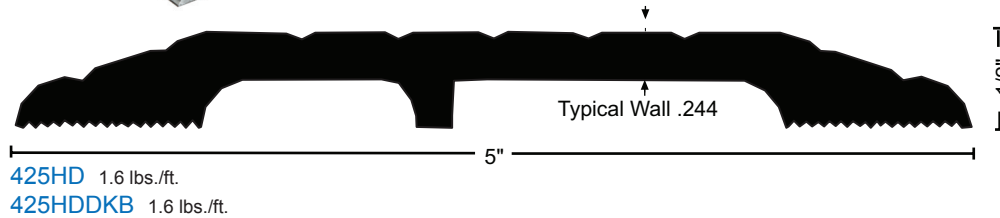

BUMPER SEAL
Seals against the door providing weather resistance

Vinyl ("V") supplied unless other material specified

Options:
NGP-TPV ("N")
Silicone ("S")

Extended Width Transitions

All Products this page



- Create wider saddle or half saddle transitions
- Furnished with aluminum spline or thermal spline for field assembly
- Optional welded assemblies

Examples - How to order:

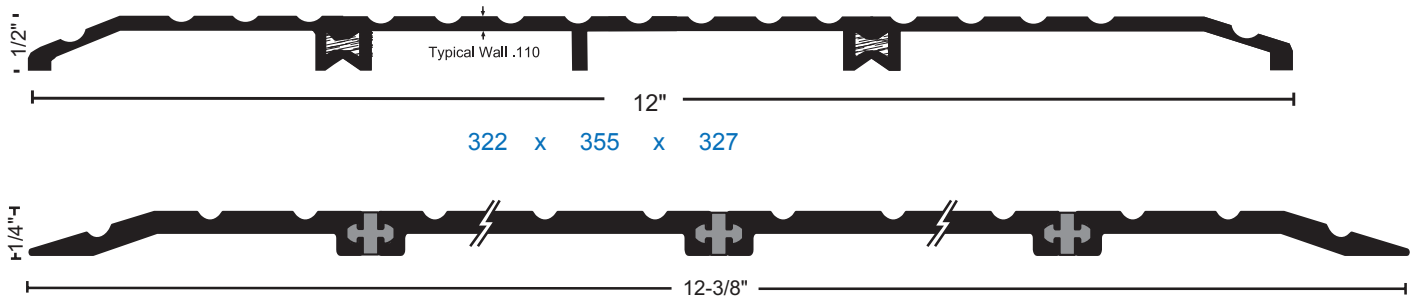

8213 1.74 lbs./ft.

8213DKB 1.74 lbs./ft.



Half Saddle and Extended Width Components

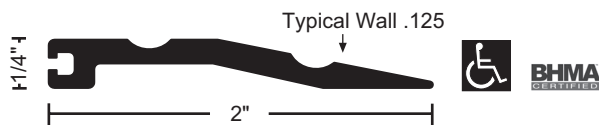

215 .28 lbs./ft.

215DKB .28 lbs./ft.



BHMA
CERTIFIED

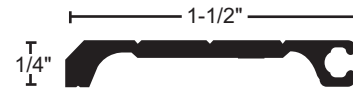

700E .20 lbs./ft.

700EDKB .20 lbs./ft.

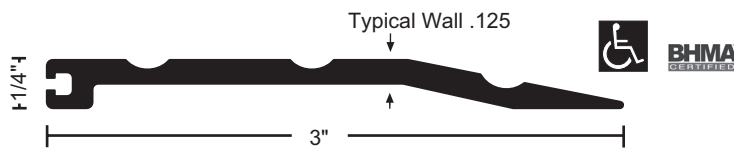

315 .41 lbs./ft.

315DKB .41 lbs./ft.



BHMA
CERTIFIED

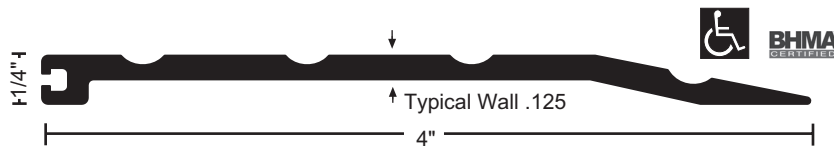

415 .55 lbs./ft.

415DKB .55 lbs./ft.



BHMA
CERTIFIED

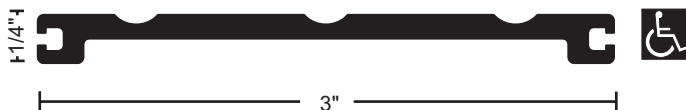

515 .45 lbs./ft.

515DKB .45 lbs./ft.



MATERIALS & FINISHES

- Aluminum mill finish
- DKB - Aluminum dark bronze finish



- Optional: Slip Resistant SIA Finish

FASTENERS

#10 x 1-1/2" FH zinc plated wood screws furnished. Dark bronze supplied with DKB transitions.

Half Saddle Transitions and Extended Width Components



All transitions this page

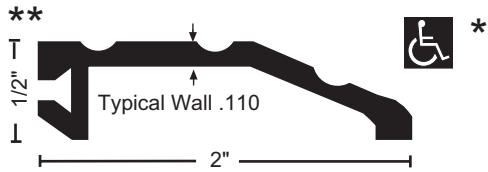

321 .34 lbs./ft.
321DKB .34 lbs./ft. **BHMA** CERTIFIED

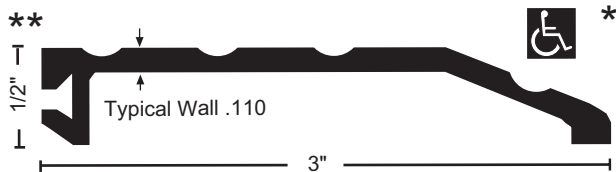

322 .48 lbs./ft.
322DKB .48 lbs./ft. **BHMA** CERTIFIED

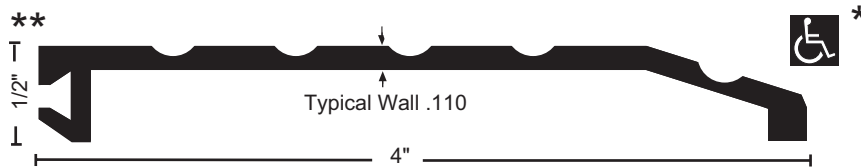

327 .60 lbs./ft.
327DKB .60 lbs./ft.

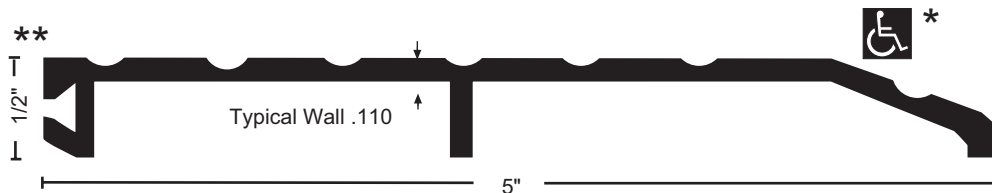

350 .83 lbs./ft.
350DKB .83 lbs./ft. **BHMA** CERTIFIED



355 .79 lbs./ft.
355DKB .79 lbs./ft. **BHMA** CERTIFIED

MATERIALS & FINISHES

- Aluminum mill finish
- DKB - Aluminum dark bronze finish



- Optional: Slip Resistant SIA Finish

FASTENERS

#10 x 1-1/2" FH zinc plated wood screws furnished. Dark bronze supplied with DKB transitions.

- * When installed with the non-beveled edge FLUSH with flooring, or where no greater than 1/4" vertical rise occurs.

- ** Designed for thermal break. Bumper seal not available.

All transitions this page



Half Saddle Transitions

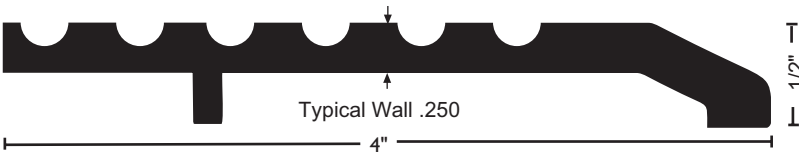

324 1.20 lbs./ft.

324DKB 1.20 lbs./ft.

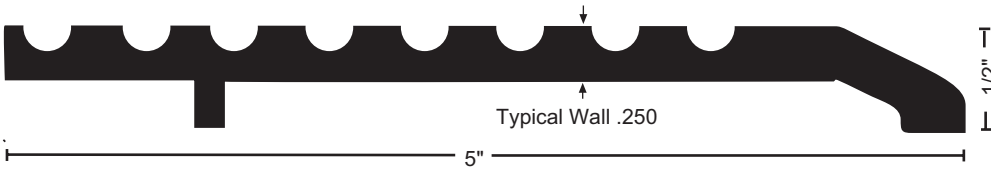

325 1.32 lbs./ft.

325DKB 1.32 lbs./ft.

* when installed with the non-beveled edge flush with flooring, or where no greater than 1/4" vertical rise occurs.

Offset Transitions

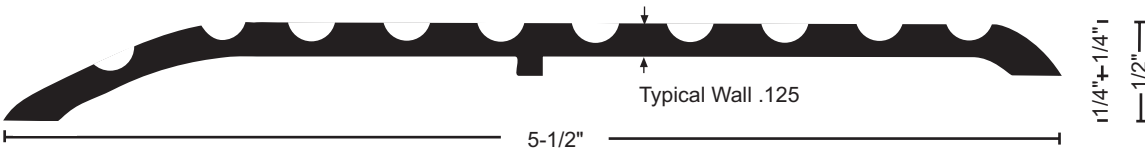

653 .78 lbs./ft.

653DKB .78 lbs./ft.

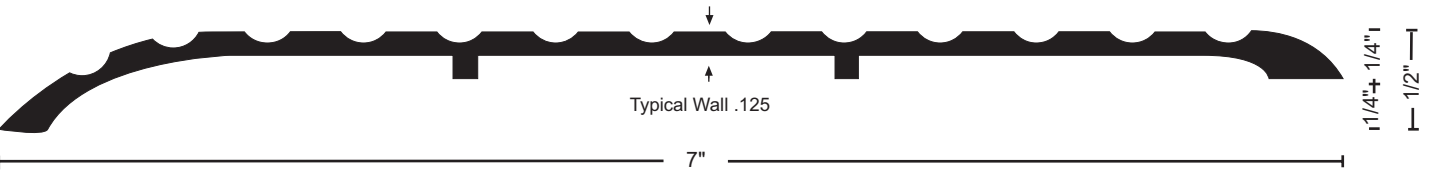

659 .89 lbs./ft.

659DKB .89 lbs./ft.

Aluminum Cover Plates

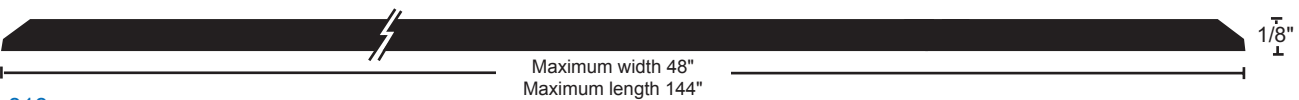

818 1/8"

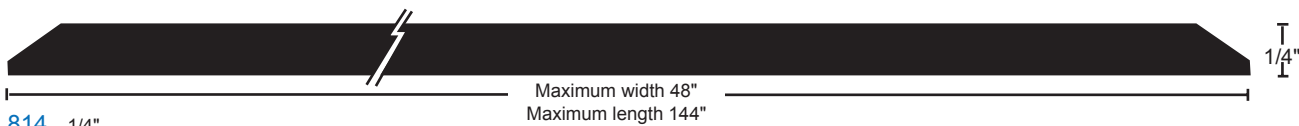

814 1/4"



838 3/8"

Return Closed Ends

Return Closed Ends (RCE's) are available on most beveled transitions. The corner is miter cut on a 45 degree angle and returned to the face of the door frame for a neat, clean, finished appearance. Specify: "RCE"

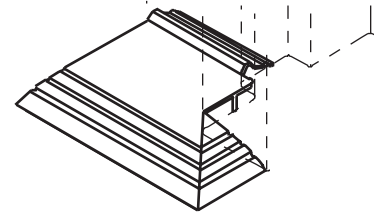

Custom Fabricated Transitions

Our Custom Fab dept. specializes in producing custom made-to order transitions to your specifications. Submit your details to our technical dept. for a quotation and drawing for your approval. Components are used to build special assemblies like the one illustrated below. Aluminum, Brass and Stainless Steel Cover Plates are also custom formed and welded to meet special requirements.

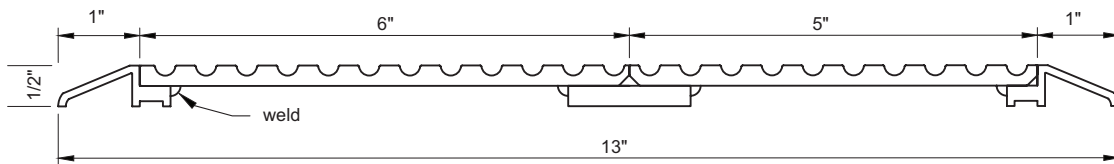

8137 x 8146 (Rip to 6") x 8145 x 8137 x Bar4 x Welded profile Assembly View

Sports Floor Transition Assemblies

Wood gymnasium sports floors are designed to be free floating. We offer transition assemblies to cover the transition from the primary floor to the sports floor. As the sports floor shifts, the transition assembly will allow expansion and contraction by the top plate moving with the sports floor.

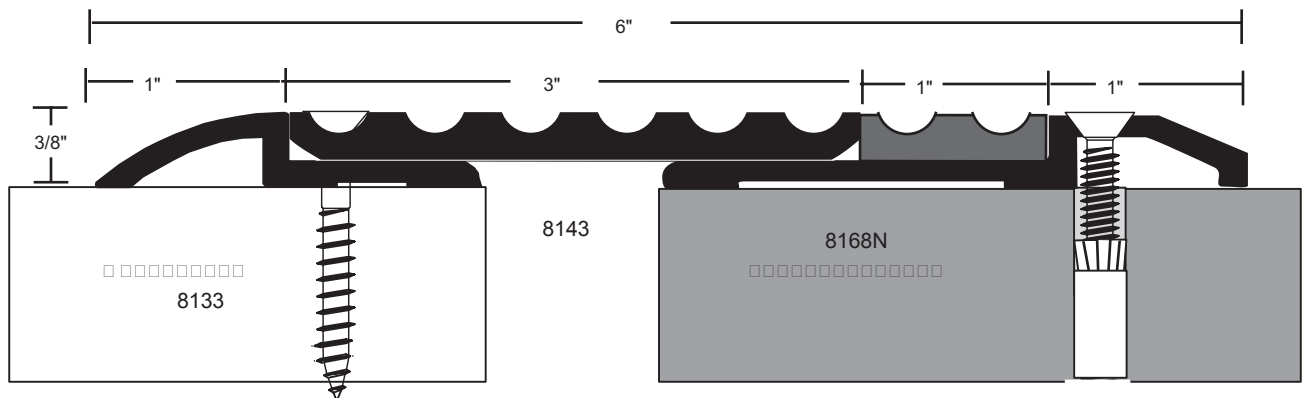

8133 x 8143 x 8168N (Neoprene) x 8139 x 10-24 MS/LA

Also available in 1/2" high and in other widths - contact NGP Technical Department

Edge Components

All transitions this page



Choose from various height and width components to build custom transitions to meet special job requirements. For assistance contact our tech support team.

Select the proper height edge components. Select the appropriate center plates to construct the width needed. Plates may be butted together or ripped to make specific widths. Support joints and wider spans with bar supports.

Transition assembly plates may be used fluted or smooth side up. Slip-resistant SIA finish can be applied to all parts.

Transition assembly components may be ordered separately for field assembly or welded into one piece units in our custom fabrication shop. They are supplied undrilled unless a template is provided. Ripping and beveling options are available. All custom fabricated assemblies have a tolerance of +/- 1/16".

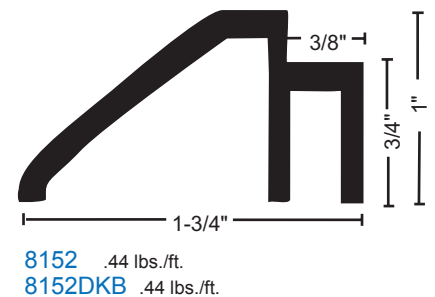
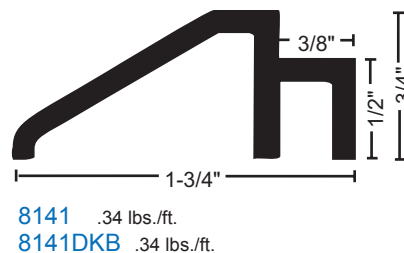
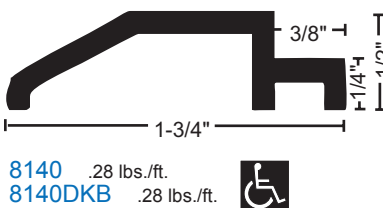
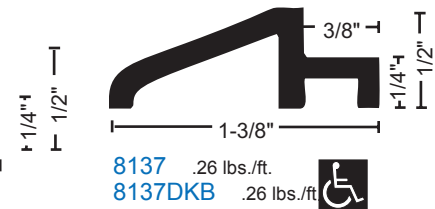
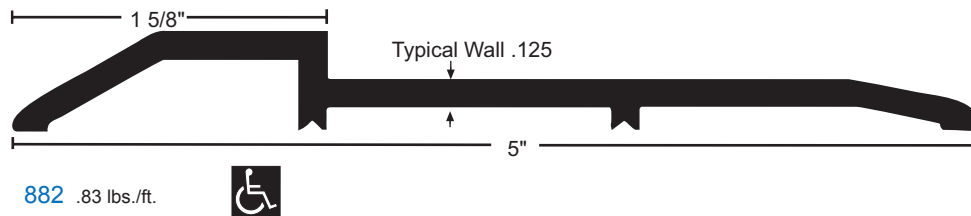
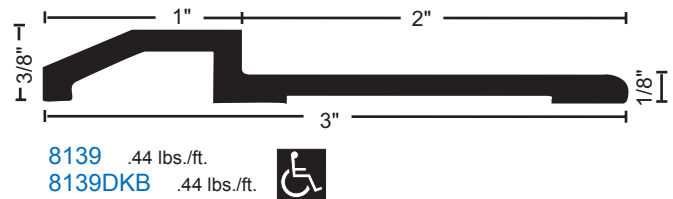
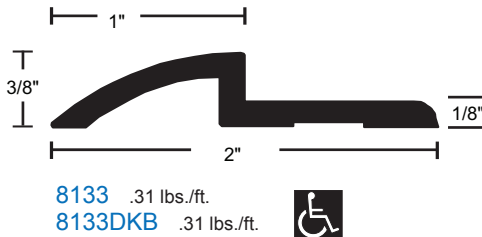
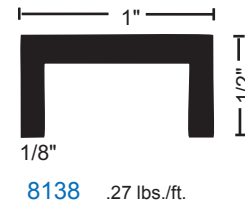
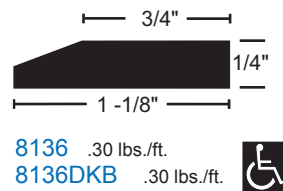
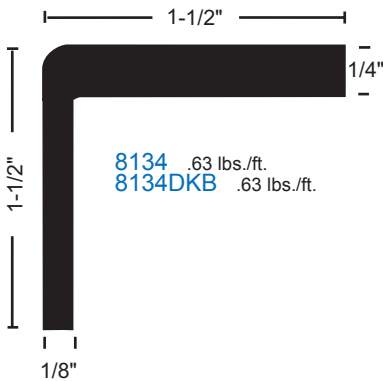

If a welded assembly is desired, specify "welded".

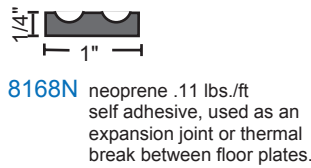
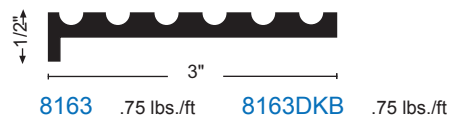
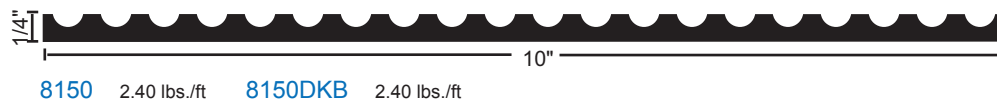
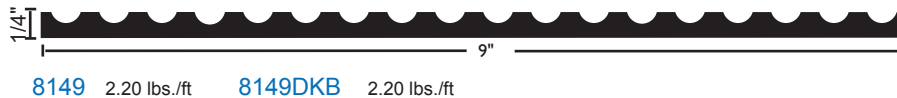
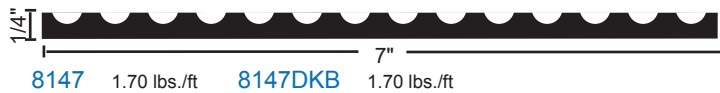
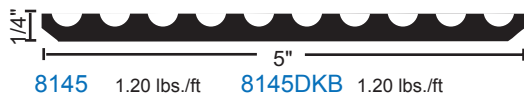
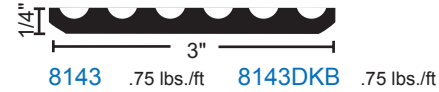
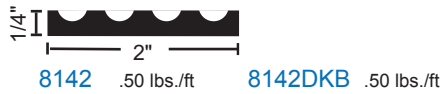

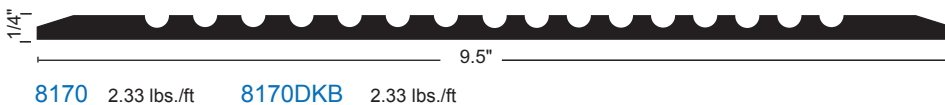
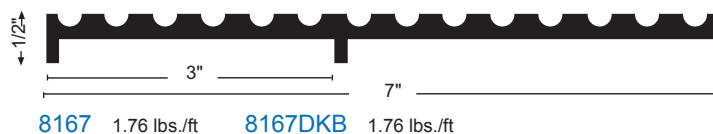

8168N neoprene .11 lbs./ft self adhesive, used as an expansion joint or thermal break between floor plates.



All transitions this page   

 except 8163, 8164, 8167

MATERIALS & FINISHES

- Aluminum mill finish
- DKB - Aluminum dark bronze finish

 • Optional: Slip Resistant SIA Finish

FASTENERS

#10 x 1-1/2" FH zinc plated wood screws furnished. Dark bronze supplied with DKB transitions.

Bar Supports

Used as support under transition assemblies

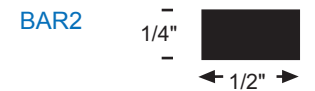
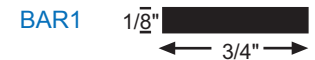

BAR4

illustrations shown at 50%

Stainless Steel 1/4" Saddle Transitions

All transitions this page

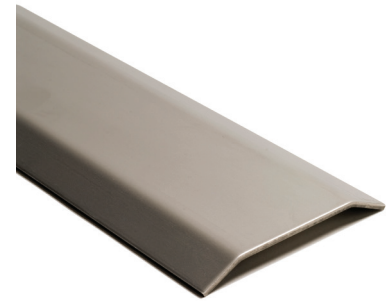
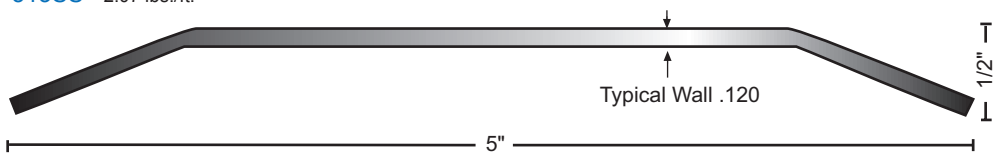
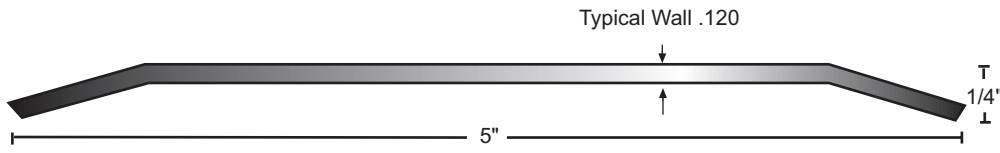

Architectural Bronze 1/4" Saddle Transitions

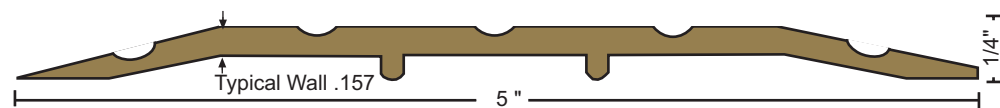
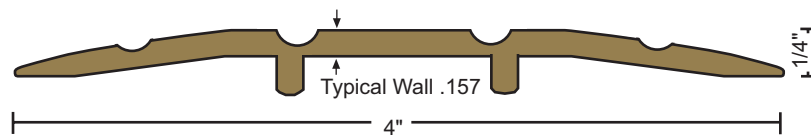
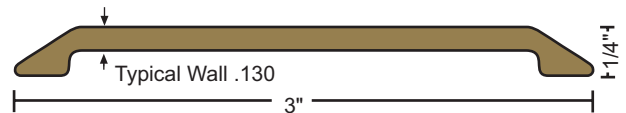

FASTENERS
 #10 X 1-1/2" solid brass
 wood screws furnished.
 Antique bronze finish
 screws provided with dark
 bronze transitions.

Architectural Bronze 1/2" Saddle Transitions

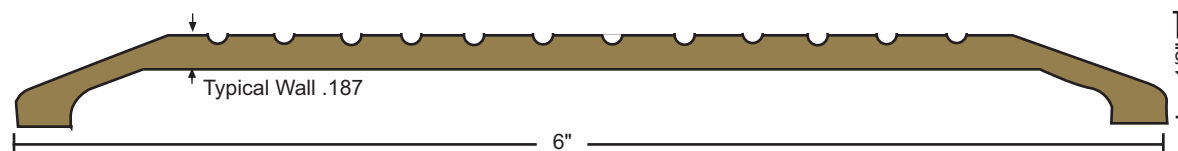
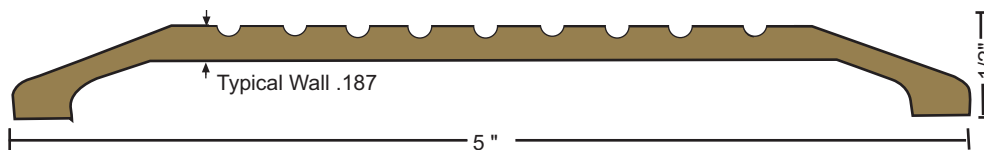
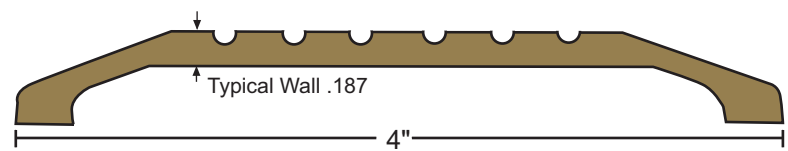

Architectural Bronze Custom Transitions

All transitions this page



Choose from various height and width components to build custom transitions to meet special job requirements. See the custom fabricated transition example illustrated on page T9. For assistance contact our tech support team.

Select the proper height edge components. Select the appropriate center plates to construct the width needed. Plates may be butted together or ripped to make specific widths. Support joints and wider spans with bar supports.

Transition assembly plates may be used fluted or smooth side up. Slip-resistant SIA finish can be applied to all parts.

Transition assembly components may be ordered separately for field assembly or welded into one piece units in our custom fabrication shop. They are supplied undrilled unless a template is provided. Ripping and beveling options are available. All custom fabricated assemblies have a tolerance of +/- 1/16".

If a welded assembly is desired, specify "welded".

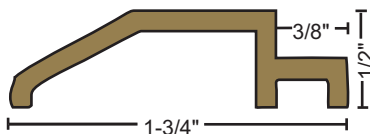

8140BR .82 lbs./ft.



8136BR .89 lbs./ft.

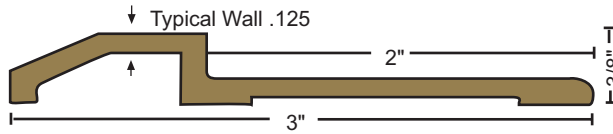

8139BR 1.25 lbs./ft.

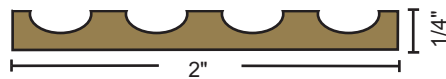

8142BR 1.30 lbs./ft.

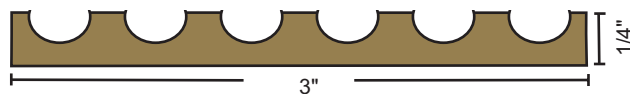

8143BR 2.07 lbs./ft.

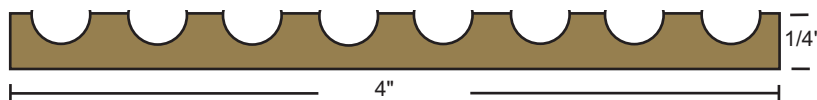

8144BR 2.88 lbs./ft.



8145BR 3.70 lbs./ft.



8146BR 4.25 lbs./ft.

Bar Supports

used as support under transition assemblies

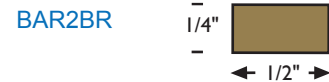
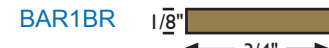

ADA Compliant Interlocking Reducers

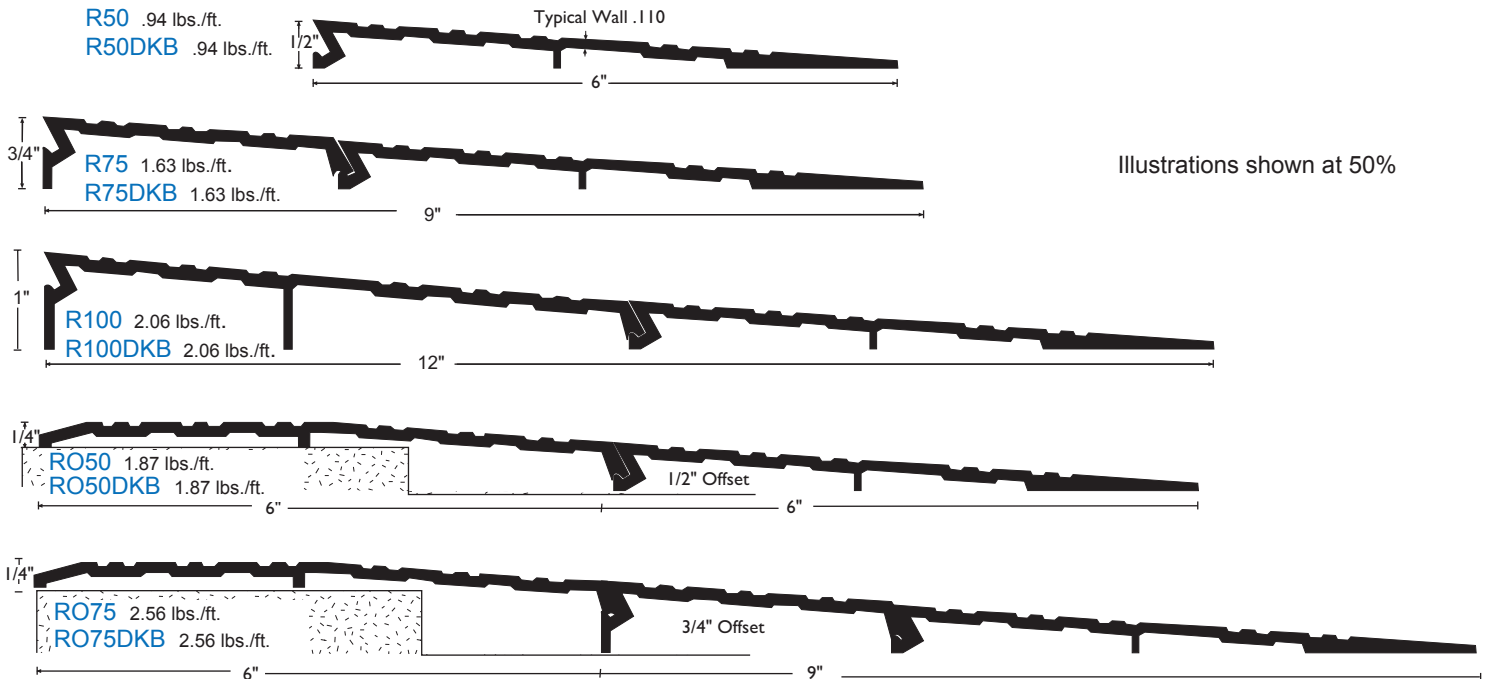

Return Closed Ends for Reducers

Return closed ends provide an attractive finished appearance to reducers. They are available in several lengths and can be trimmed to accommodate any size reducer assembly.

RCE's are also available with slip-resistant "SIA" finish (suffix "SIA").

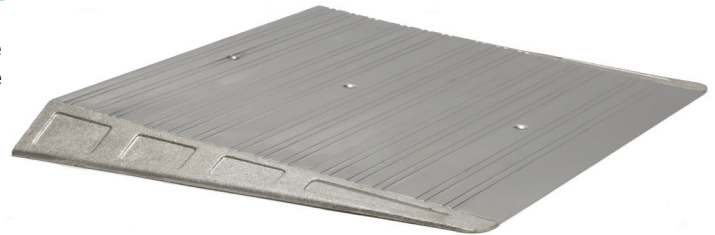

Interlocking Rubber Reducers

- Supplied with beveled ends - (end slope = 1:2). Specify if straight cut is required.
- Rubber reducer sections may be combined with aluminum reducer components for higher rises, or with 6" flat aluminum interlocking transition #957 for offset conditions.
- Black silicone adhesive available to secure reducers without fasteners. Specify RR5007BL, each tube will secure 2 reducers 12" wide x 36" long (6 square feet.)

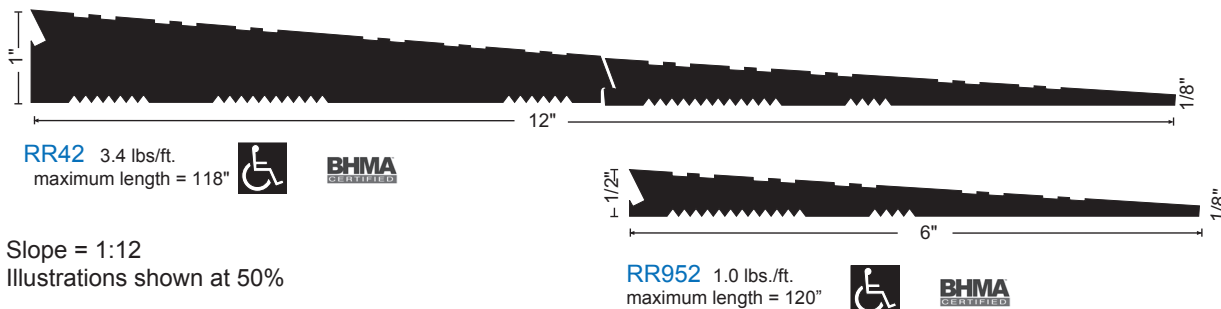

Transition Fasteners

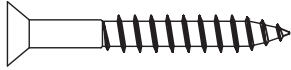

#10 x 1 1/2" Phillips Flat Head Wood Screw
Use 1/8" Drill bit



Phillips Head
Top View



Spanner Head
Top View



Torx Security
Top View



#12 x 1 1/2" Phillips Flat Head Wood Screw
Use 9/64" Drill bit
Also #12 x 1"

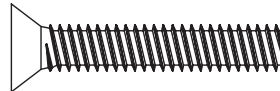

#1/4-20 x 1 1/2" Phillips Flat Head
Machine Screw



#1/4-20 Expansion Anchor
Carbon Steel
Use 3/8" Drill bit

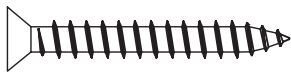

#10 x 1 1/2" Phillips Flat Head Stainless Steel
Sheet Metal Screw
Use 1/8" Drill bit
Also #10 x 1", #10 x 2", #10 x 2 1/2", #10 x 3"



#10-24 x 1 1/2" Phillips Flat Head
Machine Screw
Also #10-24 x 3/4", #10-24 x 1"



#10-24 Lead Anchor
Use 3/8" Drill bit and
Powers seating tool



#12 x 1 1/2" Phillips Flat Head
Sheet Metal Screw
Use 9/64" Drill bit
Also: #12 x 1"

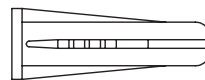

Plastic Anchor Various Sizes
Use Drill Size = Anchor Size

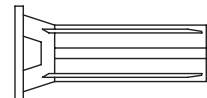

Lead Expansion Shield
4% Antimonial Lead
Use 5/16" Drill bit



#6 x 3/4" Phillips Flat Head Self-tapping
Machine Screw
Use 3/32" Drill bit

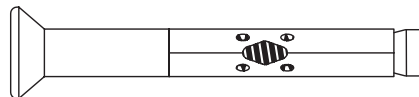

#1/4-20 Phillips Combo Flat Head Machine
Screw/Anchor
Use 1/4" Drill bit



#18 x 7/8" Nail for use with 80B
Hook Strip

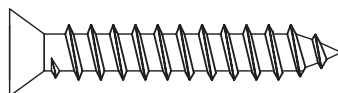

Hilti Kwik-Con II Torx Head Screw, Use Hilti
TKC large concrete bit SDS 1/4" Tough
Carbide

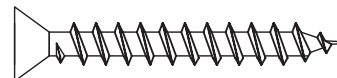

Tap-Con type Phillips Head Screw
Use 5/32" Drill bit

