

Template



This Set Screw Is On Selector Hold-open Types Only

Closing speeds can be adjusted to suit local conditions and requirements. Label on closer face designates the purpose of each adjustment screw. Adjustments are for speed control.

- A. The Delay Action valve allows adjustment from full open to 65° closed position. (Optional)
- B. The Closing Speed valve allows adjustment from full open to 15° on units without the Delay Action feature.
- C. The Closing Speed valve allows adjustment from 65° to 15° closed position on closers with Delay Action feature.
- D. Latch valve allows adjustment from 15° to closed position.
- E. Important: Backcheck adjustment must be adjusted to vary resistance from light to firm at 60° of door open.

Do not use Backcheck as deadstop. This is an intensity valve not speed control.

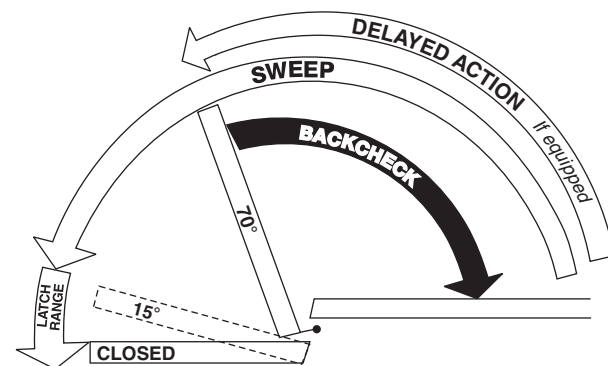

Closer Type

This closer is one of three types as follows:

- 1. Non hold-open factory set. No hold-open adjustments.
- 2. Automatic hold-open factory set. No hold-open adjustment.
- 3. Selective (on-off) hold-open label will indicate position of on-off selector screw. When turned "on", closer has automatic hold-open: turned "off", hold-open will not function. Turn full 180°.

Spring Power Adjustments

This closer can be adjusted for increased or decreased spring power.

These adjustments if required should be done by an authorized repair agency.

Repairs, parts replacement or internal adjustments must be done by a Rixson authorized repair agency. Consult www.rixson.com for an authorized repair agency in your area.

ASSA ABLOY is the global leader in door opening solutions, dedicated to satisfying end-user needs for security, safety and convenience. Copyright © 2003, 2009. ASSA ABLOY Accessories and Door Controls Group, Inc. All rights reserved. Reproduction in whole or in part without the express written permission of ASSA ABLOY Accessories and Door Controls Group, Inc. is prohibited.



GLASS DOOR PREPARATION

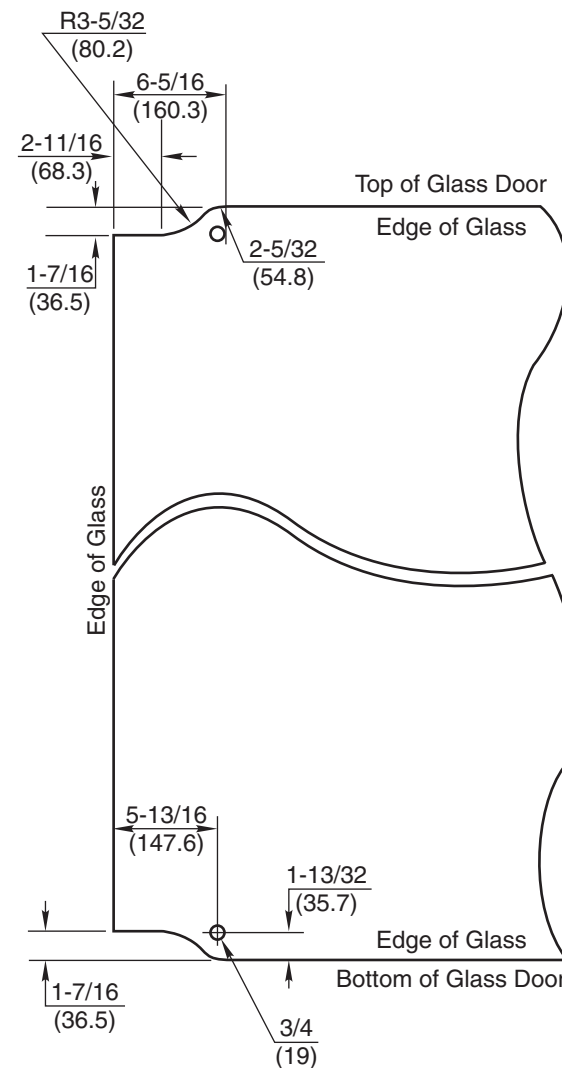

- Notes:
- 1. Do not scale drawing.
 - 2. Suitable reinforcing by others.
 - 3. With 1/4" threshold order 1/4" longer spindle. With 1/2" threshold order 1/2" longer spindle.
 - 4. For use only on glass doors using patch fittings.
 - 5. All dimensions given in inches (mm).

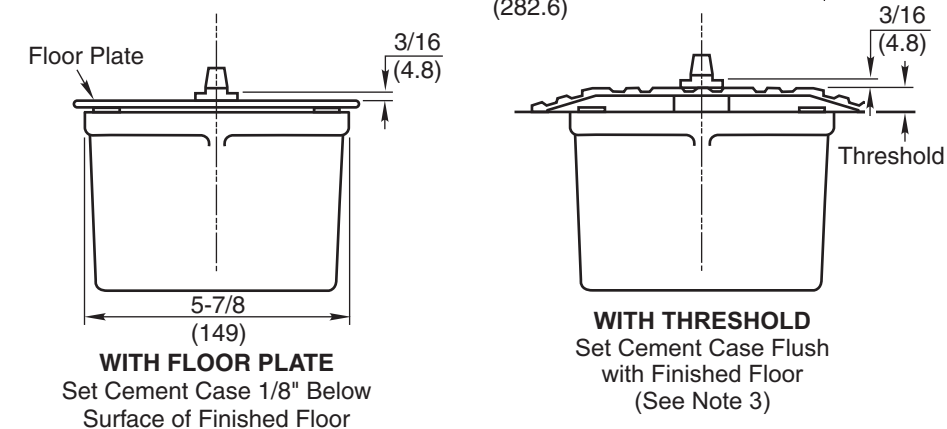
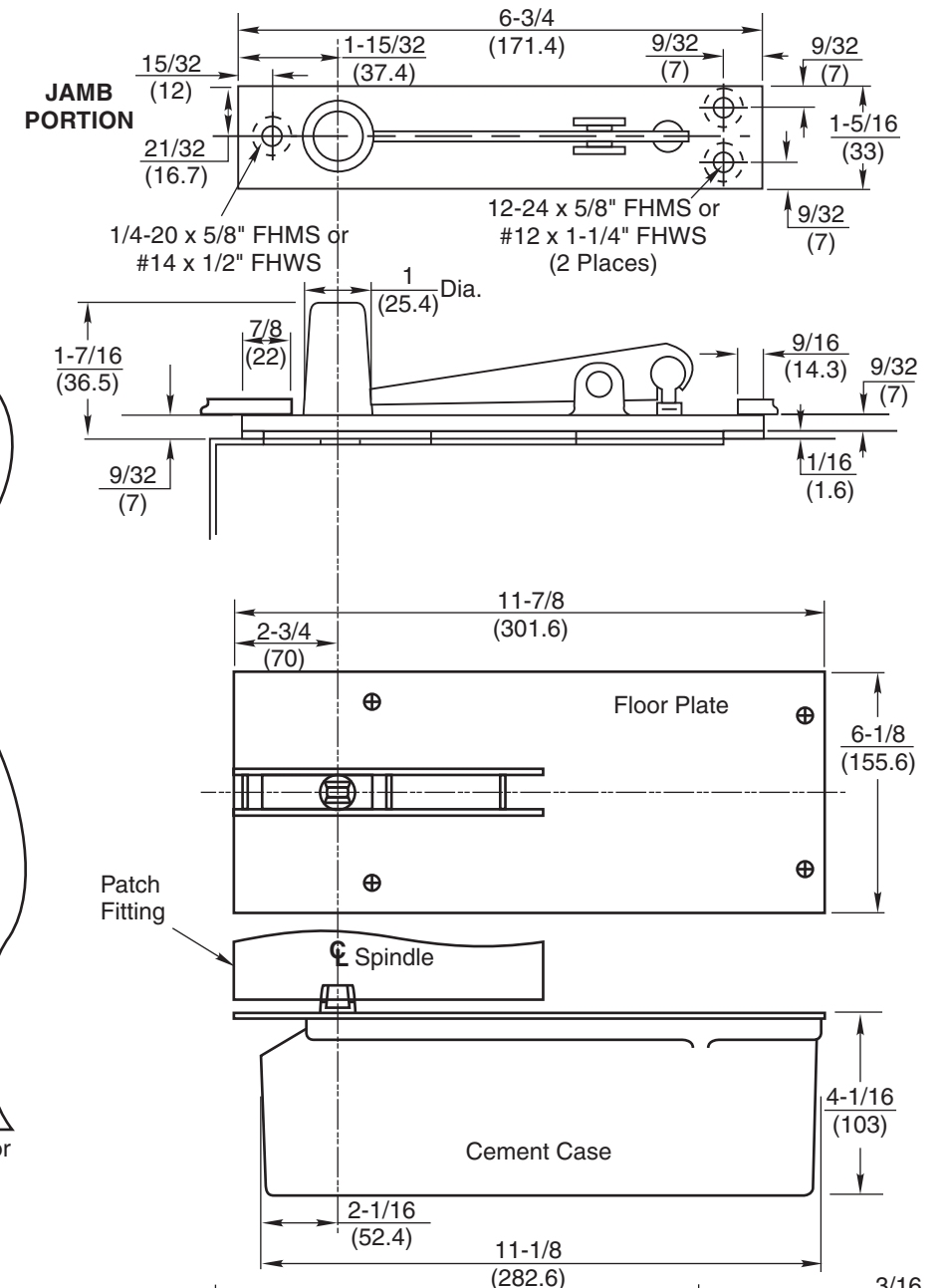

WITH FLOOR PLATE
Set Cement Case 1/8" Below Surface of Finished Floor

WITH THRESHOLD
Set Cement Case Flush with Finished Floor (See Note 3)

How To Determine Hand of Door

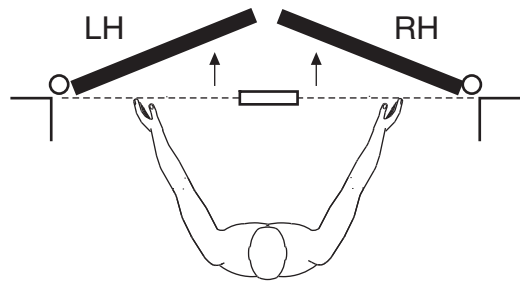

Face a door swinging open away from you. If it opens to the right, it is right hand. If it opens to the left, it is left hand.

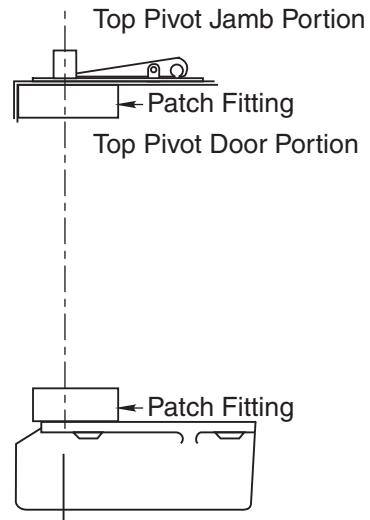

IMPORTANT:

Use plumb line to make sure that center line of top pivot pin lines up with center line of closer spindle.

3. Install Pivot

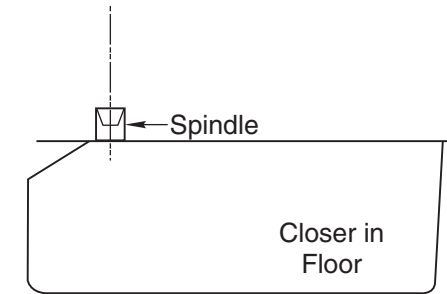
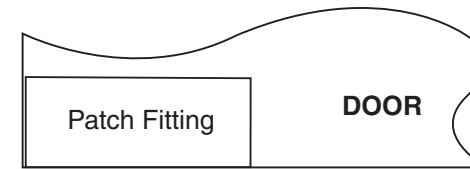

- A. Install patch fittings (top & bottom) into door per template.
- B. Install top pivot in jamb per template.
- C. Centerline of pivot pin should line up with centerline of spindle. Use plumb line to assure accuracy.

Installation Instructions

1. Locating Closer

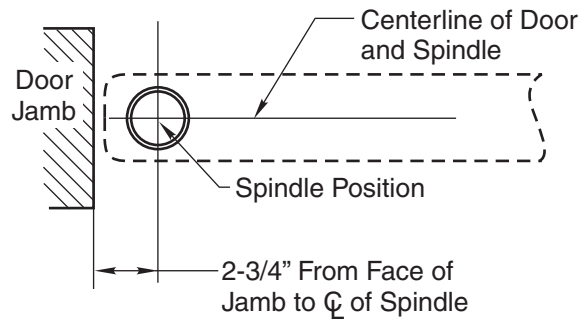

- A. Measure 2-3/4" out from door jamb on centerline of door. This is the location of the spindle center.

4. Hang Door

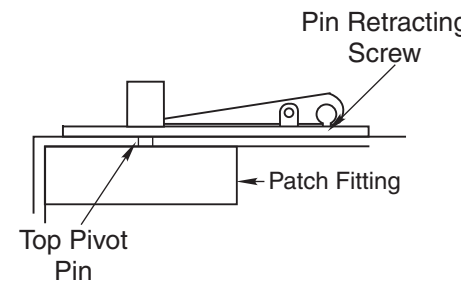

CAUTION: Closer is shipped with valve screws down. DO NOT FORCE VALVES DOWN.

- A. Retract top pivot pin by turning retracting pin screw counterclockwise. (see illustration)
- B. Using wrench, turn until arm is in 30° open position. (see illustration)
- C. Set door on spindle. DO NOT ATTEMPT TO CLOSE DOOR.
- D. Align jamb portion of the pivot with top patch and turn pin retracting screw clockwise.
- E. Open door to 60° or more and open "closing speed" and "latch" valves by turning screws counterclockwise. Door will then close.

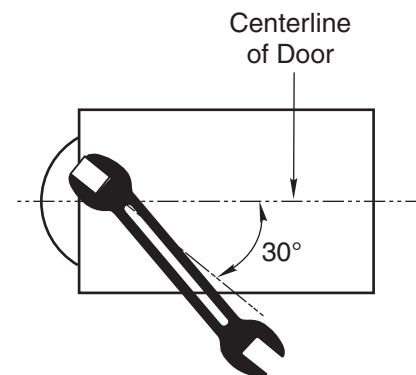

2. Install Cement Case in Floor

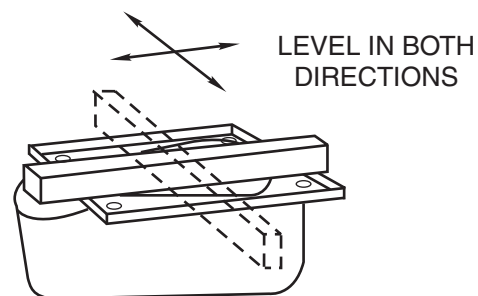

- A. For floor plate application: Cement case is set 1/8" (3.2mm) below floor level.
- B. For threshold application: Cement case is set flush with floor.
- C. Set cement case in floor and block in position.
- D. Case should be parallel with center line of door.
- E. CEMENT CASE SHOULD BE LEVEL. Place levels per illustration.
- F. Grout in cement case with closer. Cement should not get between closer and case.