

Where vertical adjustment is necessary two 1/16" thick shims are provided to be placed between arm & arm bearing washer.

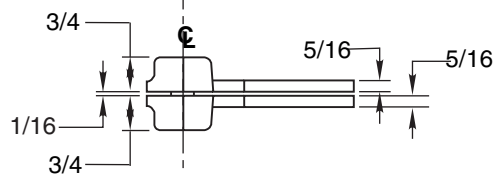

Door Mortised "A" Deep for Arm	"A"
1/4 Threshold	1
1/2 Threshold	3/4

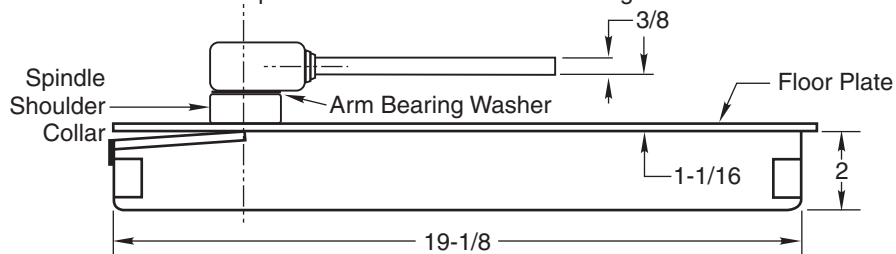
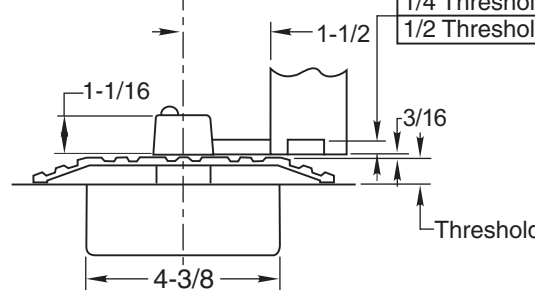

WITH THRESHOLD
 Set Cement Case Flush with Finished Floor

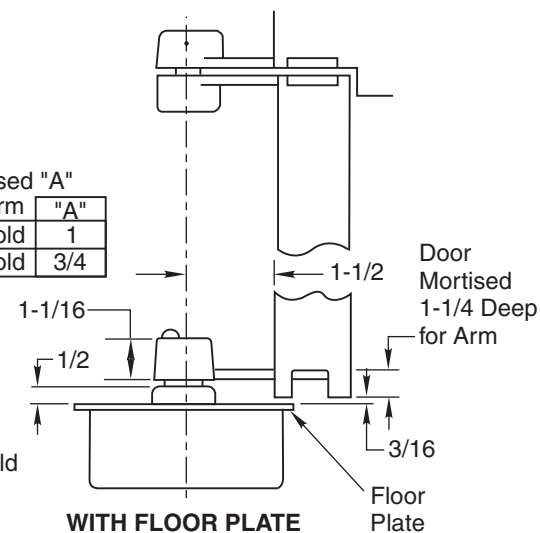

WITH FLOOR PLATE
 Set Cement Case Flush With Finished Floor

Notes:

1. Do not scale drawing.
2. Right Hand Shown.
3. All dimensions given in inches. Conversion from inches to metric: inch x 25.4
4. Norton Rixson design thresholds available on request.
5. Do not remove grind plate until closer is installed.
6. No built-in dead stop. External stop required, by others.

**51 Floor Closer
 1-1/2" Offset**



ASSA ABLOY

TEMPLATE NUMBER	REV	DATE
OS10205	3	12/21