

# 433 MHz TRANSMITTERS & RECEIVER

## USER'S GUIDE

FCC ID#: G9B-10TD433HH4

IC ID#: 4680A-10TD433HH4

DIGITAL TRANSMITTERS AND RECEIVER WITH SEQUENCING FUNCTION

### 1. Description

The 433MHz Series Transmitters and Receiver are ideal for the wireless activation and/or sequencing of automatic doors. The Transmitters are available in hand-held or pushplate styles and they transmit a unique rolling code each time the transmitter is activated (thus providing a secure door opening signal). The transmitter is powered by either a 3-volt or a standard 9-volt battery and illuminates a Red LED when activated.



ONE BUTTON

TWO BUTTON

Since receivers can be individually programmed, multiple receivers can be programmed differently thus allowing for sequencing in multiple applications. Upon activation (pushplate / transmitter), all receivers will acquire the signal at the same time; however, each receiver will respond according to their programming. Those receivers programmed with NO DELAY will active immediately upon receiving the transmitter signal. Those receivers programmed with a DELAY will activate at the end of their pre-determined time delay set by the potentiometer. The use of multiple receivers will allow for the uninterrupted pace or hands free operations through a pair of doors upon initial activation.

### 2. Specifications

DESCRIPTION		SPECIFICATION
FREQUENCY		433 MHz
EMITTED RADIO POWER		-28.7 dBm (TX)
POWER CONSUMPTION		3mA (TX) 30mA (RX)
INPUT VOLTAGE		12 to 24 VAC/DC (RX)
CONTACT RATING		1.0 A @ 30 VDC
		0.5 A @ 125 VAC
		0.3 A @ 60 VDC
OPERATING TEMPERATURE		14°F TO 131°F (-10°C TO 55°C)
MAX No. OF PROGRAMMED UNITS PER RECEIVER		100 TRANSMITTERS
LEDs	Receiver Learn	RED
	Relay Activation	BLUE
DIMENSIONS	Transmitter	2-3/4" x 1-3/8" x 9/16" (70mm x 35mm x 14mm)
	Receiver	2-3/4" x 2-1/8" x 1" (70mm x 55mm x 25mm)
CERTIFICATIONS		FCC, IC,

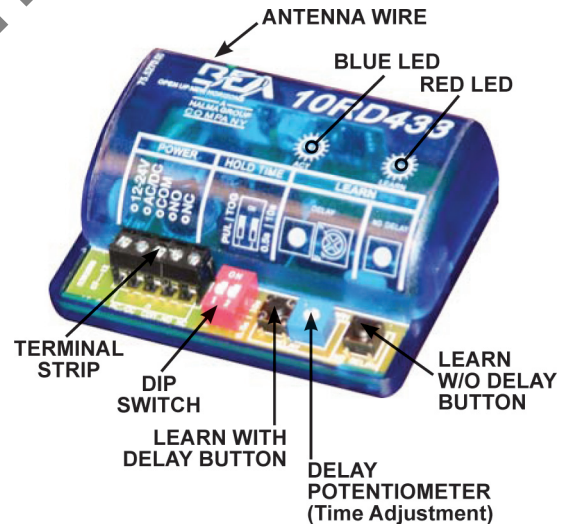

### 3. Precautions



CAUTION

- This product IS NOT intended for use with Maglocks / Electric Strikes.
- Shut off all power going to work area before attempting any wiring procedures.
- Maintain a clean & safe environment when working in public areas.
- To remain in compliance with Part 15.231, do not operate transmitter (hold down button ) for longer than 5 seconds.
- Constantly be aware of pedestrian traffic around the area.
- Always stop pedestrian traffic through the doorway when performing tests that may result in unexpected reactions by the door.
- ESD: Circuit boards are vulnerable to damage by electrostatic discharge. Before handling ensure you dissipate your body's charge.
- Always check placement of components before powering up so that moving parts will not catch any wires or cause damage to equipment.
- Ensure compliance with all applicable safety standards (i.e. ANSI A156.10 / 19) upon completion of installation.
- DO NOT attempt any internal repair of the components. Unauthorized disassembly or repair:
  1. May jeopardize personal safety and may expose one to the risk of electrical shock.
  2. May adversely affect the safe and reliable performance of the product resulting in a voided warranty.

## 4. Programming

### 1 DIP SWITCH SETTINGS

# 1	DESCRIPTION	FUNCTION
OFF	Pulse Relay	Press the transmitter once and the relay will be active momentarily.
ON	Toggle Relay	Press the transmitter once and the relay output is active indefinitely, press it again and the relay will de-energize indefinitely.

# 2	DESCRIPTION	FUNCTION (Pulse Mode Only)
OFF	0.5 sec Hold Time	Relay will remain active 0.5 second after the loss of activation.
ON	10 sec Hold Time	Relay will remain active 10 seconds after the loss of activation.

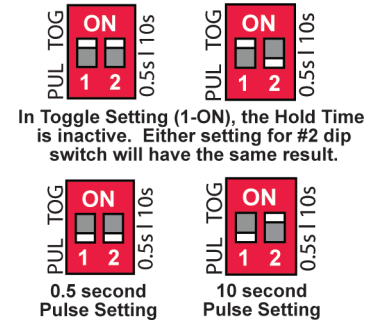

### 2 HAND HELD CONFIGURATION

- Set dip switches on the receiver to the desired activation cycle (dip switch 1 -Toggle or Pulse and dip switch 2 - 0.5s or 10s hold).
- Press either Learn w/Delay Button or Learn w/No Delay Button on the receiver depending on the activation requirements (If delay learn is selected, adjust potentiometer to counterclockwise limit, 0 second delay). After learn cycle is complete, adjust potentiometer to desired delay time (0-30 sec).
- Depress transmitter button repeatedly until Blue LED on the receiver illuminates (indicating reception of signal from transmitter).  
NOTE: Repeat Steps 2-3 to program additional transmitters.
- To test the system, depress transmitter button (Red LED on Transmitter will illuminate) and observe that the Blue LED illuminates on the receiver. This indicates that the relay has been activated.

### 3 PUSH PLATE CONFIGURATION

- Before beginning, it is easiest to have already prepared the installation of the pushplate.
- Connect the wires from the transmitter to the NO and COM contacts of the pushplates switch.
- Follow Steps 1-4 (Hand-Held Configuration); depress the pushplate to activate the transmitter.
- Attach the transmitter to the inside of the electrical box and complete the installation.

### 4 TYPICAL VESTIBULE APPLICATION

#### A OUTSIDE TRANSMITTER (PUSH PLATE)

- Press Learn w/NO DELAY BUTTON on OUTER Receiver then press Transmitter 1.
- Press Learn w/DELAY BUTTON on INNER Receiver then press Transmitter 1.

NOTE: Set Potentiometer to desired Delay Time per Hand Held Configuration Step #2.

#### B INSIDE TRANSMITTER (PUSH PLATE)

- Press Learn w/NO DELAY BUTTON on INNER Receiver then press Transmitter 2.
- Press Learn w/DELAY BUTTON on OUTER Receiver then press Transmitter 2.

NOTE: Set Potentiometer to desired Delay Time per Hand Held Configuration Step #2.

#### C VESTIBULE TRANSMITTERS (Dual Switch Pushplate or Two Separate Pushplates)

- Press Learn w/NO DELAY BUTTON on INNER Receiver then press Transmitter 3.
- Press Learn w/NO DELAY BUTTON on OUTER Receiver then press Transmitter 4.

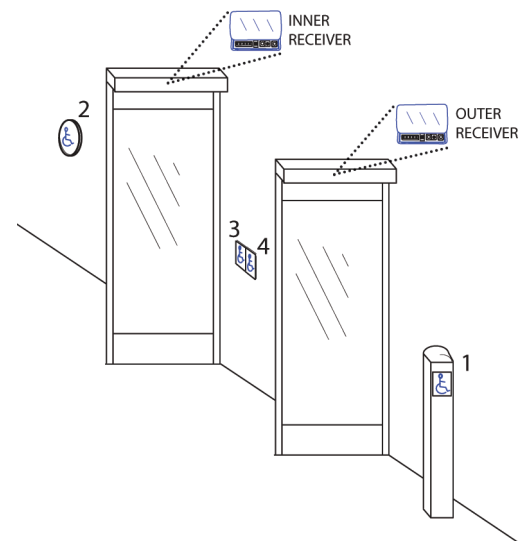

### 5 REMOVING TRANSMITTER CODE(S)

#### SINGLE TRANSMITTER CODE

- Press both DELAY and NO DELAY BUTTONS simultaneously until Red LED flashes once (approx. 1 second).
- Press transmitter button twice within 10 seconds and the transmitter code will be deleted.

#### ALL TRANSMITTER CODES

- Press and hold both DELAY and NO DELAY BUTTONS simultaneously until Blue LED illuminates then release (approx. 10 seconds).

## 5. Battery Replacement



CAUTION: THERE IS A RISK OF EXPLOSION IF AN INCORRECT BATTERY TYPE IS USED. DISPOSE OF USED BATTERIES ACCORDING TO THE INSTRUCTIONS.

<b>1</b>	<b>3 - VOLT TRANSMITTERS</b>
1.	Remove two screws from back of transmitter.
2.	Separate housing and install a fresh 3-Volt (Type CR2032) battery making sure to observe proper polarity.
3.	Reassemble housing and replace screws.
<b>2</b>	<b>9 - VOLT TRANSMITTER</b>
1.	Remove old battery.
2.	Connect a fresh 9-Volt (Type 6LR61) battery making sure to observe proper polarity.

NOTE: Don't throw used batteries away with the general trash. Discard per your local municipal laws and regulations.

## 6. FCC Compliance

- This Digital Transmitter complies with Part 15 of the FCC rules. Operation is subject to the following two conditions:
  - 1) This device may not cause harmful interference and;
  - 2) This device must accept any interference received including interference that may cause undesired operations.
    - a) This equipment has been tested and found to comply with the limits for a Class B digital device, pursuant to part 15 of the FCC Rules. These limits are designed to provide a reasonable protection against harmful interference in a residential installation. This equipment generates, uses and can radiate radio frequency energy and, if not installed and used in accordance with the instruction, may cause harmful interference to radio communications. However, there is no guarantee that interference will not occur in a particular installation. If this equipment does cause harmful interference to radio or television reception, which can be determined by turning the equipment off and on, the user is encouraged to try to correct the interference by one or more of the following measures:
      - Reorient or relocate the receiving antenna.
      - Increase the separation between the equipment and receiver.
      - Connect the equipment into an outlet on a circuit different from that to which the receiver is connected.
      - Consult the dealer or an experienced radio/ TV technician for help.
      - This transmitter operates in the band 40.66 - 40.70 MHz & above 70 MHz and is restricted to periodic transmissions of up to 5 seconds.
      - Changes or modifications for compliance could void the user's authority to operate the equipment.