

5700 Series Power Operator Conversion PUSH to PULL and PULL to PUSH Application

Patents: 5,881,497; 7,316,096; 7,484,333

⚠ WARNING

This product can expose you to lead which is known to the state of California to cause cancer and birth defects or other reproductive harm.

For more information go to: www.P65warnings.ca.gov.

Pour la version française voir NortonRixson.com.
READ AND FOLLOW ALL INSTRUCTIONS.
SAVE THESE INSTRUCTIONS.

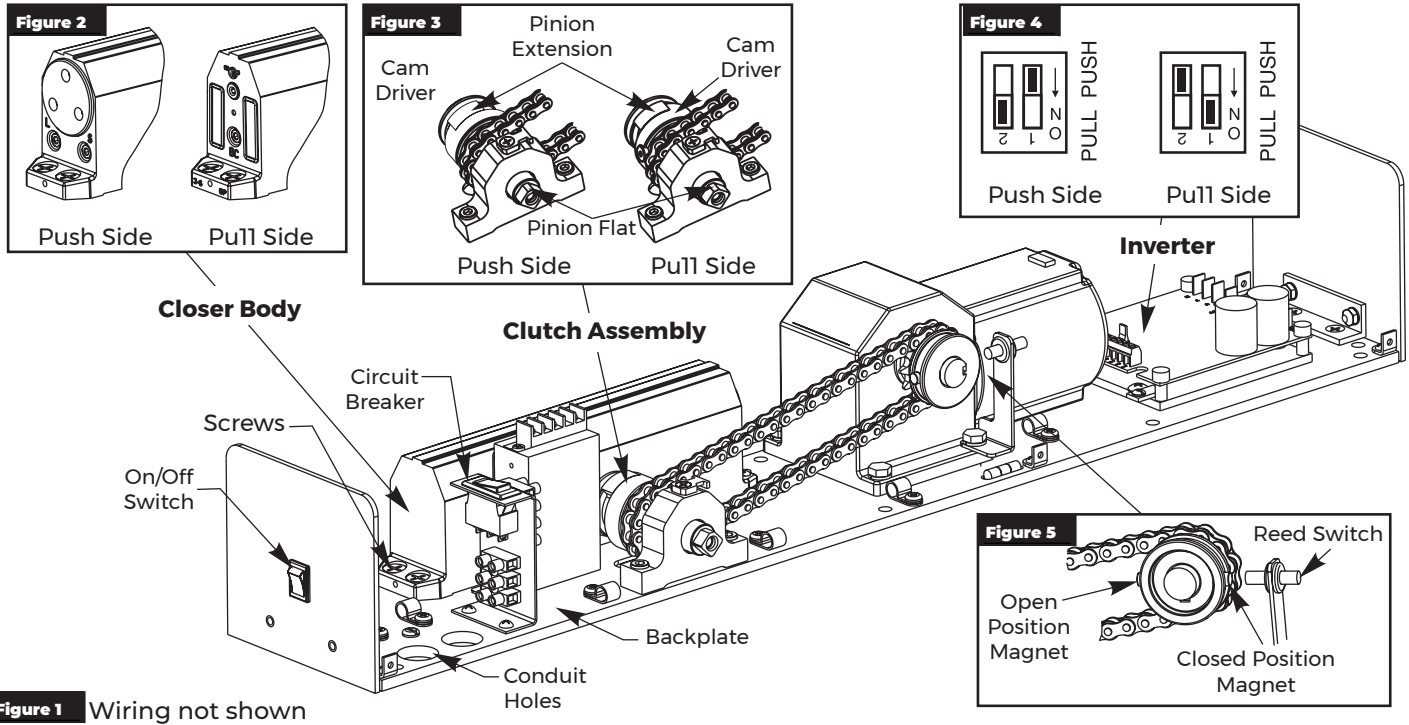

Changing Operator From Push Side Unit to Pull Side Unit

- Verify unit is configured for a push side application:
 - Latch and Sweep valves are toward conduit holes. (Figure 2)
 - Cam driver of clutch mechanism is toward conduit holes. (Figure 3)
 - Turn off power to unit at On/Off switch and flip circuit breaker to OFF position. (Figure 1)
 - Using a Phillips head screwdriver, remove four (4) closer body screws and slide closer body away from clutch assembly. (Figure 1)
- ⚠ NOTE:** DO NOT remove pinion extension when removing closer body. (Figure 3)
- Orient closer body with BC valve toward conduit holes and slide onto backplate so that pinion shaft of closer is inserted into pinion extension of clutch assembly. (Figure 2)
- NOTE:** Some rotational adjustment of pinion extension may be required to allow reassembly of closer pinion shaft and pinion extension. Pinion flat should remain opposite of backplate for proper reassembly. (Figure 3)
- Replace and tighten closer body screws.
 - Slide dip switch 1 on inverter from PUSH to PULL position. Slide dip switch 2 from ON to OFF position. (Figure 4)
- NOTE:** Inverter Details located on page 3.
- Turn on power to unit at On/Off switch and flip circuit breaker to RESET position.
 - Immediately after activating unit, watch cam driver as it rotates around. As soon as cam driver contacts pinion extension, flip circuit breaker to OFF position. (Figure 3)
 - With door closed:
 - Slide closed position magnet so it aligns with reed switch. (Figure 5)
 - Slide open position magnet so it is 180° from reed switch. Slide magnet as needed to get proper door opening. (Figure 5)
 - Flip circuit breaker to RESET position.

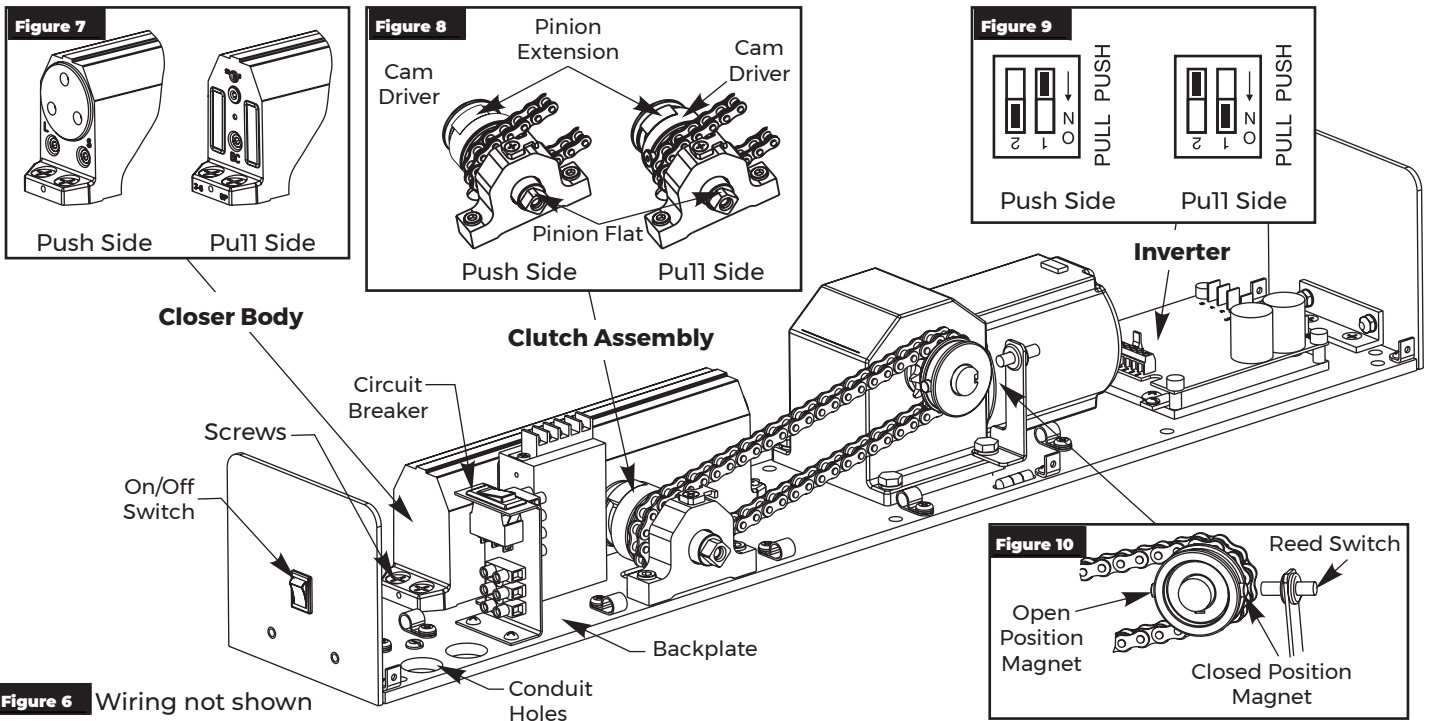

Changing Operator From Pull Side Unit to Push Side Unit

1. Verify unit is configured for a pull side application:
 - BC valve is toward conduit holes. (Figure 7)
 - Cam driver of clutch mechanism is away from conduit holes. (Figure 8)
 2. Turn off power to unit at On/Off switch and flip circuit breaker to OFF position. (Figure 6)
 3. Using a Phillips head screwdriver, remove four (4) closer body screws and slide closer body away from clutch assembly. (Figure 6)
- NOTE:** DO NOT remove pinion extension when removing closer body. (Figure 8)
4. Orient closer body with latch and sweep valves toward conduit holes and slide onto backplate so that pinion shaft of closer is inserted into pinion extension of clutch assembly. (Figure 7)

NOTE: Some rotational adjustment of pinion extension may be required to allow reassembly of closer pinion shaft and pinion extension. Pinion flat should remain opposite of backplate for proper reassembly. (Figure 8)
 5. Replace and tighten closer body screws.
 6. Slide dip switch 1 on inverter from PULL to PUSH position. Slide dip switch 2 from OFF to ON position. (Figure 9)

NOTE: Inverter Details located on page 3.
 7. Turn on power to unit at On/Off switch and flip circuit breaker to RESET position.
 8. Immediately after activating unit, watch cam driver as it rotates around. As soon as cam driver contacts pinion extension, flip circuit breaker to OFF position. (Figure 8)
 9. With door closed:
 - Slide closed position magnet so it aligns with reed switch. (Figure 10)
 - Slide open position magnet so it is 180° from reed switch. Slide magnet as needed to get proper door opening. (Figure 10)
 10. Flip circuit breaker to RESET position.

Inverter Details

Inverter Adjustments

Based on function adjustment desired, use table to determine which POT is to be adjusted.

Based on Push or Pull installation, use SW501 dip switch to change setting.

WARNING
120 High Volt Potential Present
Ensure Power is off when making adjustments.

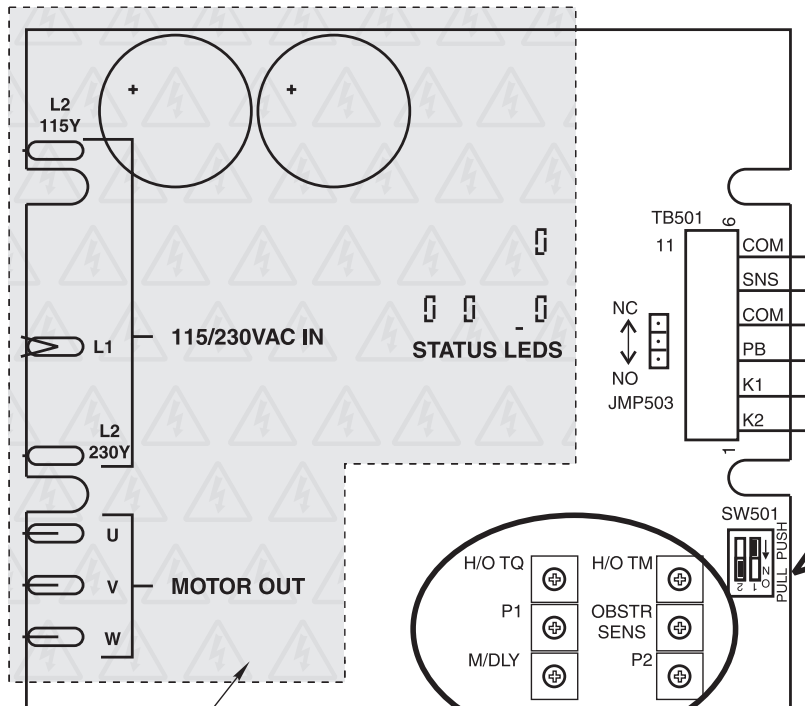

Dip Switch Settings
SW501

1. Door Mounting - ON - Pull
 OFF - Push

2. Push Recognition - ON - Active
 OFF - Inactive



WARNING
Electric Shock Risk

(Adjustments made in the shaded area should be performed by Authorized Factory Personnel)

POT	Description	Function
M/DLY	Motor Delay on Opening	CW - Increase CCW - Decrease
OBSTR SENS	Obstruction Detection on Open	CW - Increase CCW - Decrease
P1	Closing Speed	CW - Increase CCW - Decrease
H/O TM	Hold Open Time (5 - 30 seconds)	CW - Increase CCW - Decrease
H/O TQ	Motor Torque at Hold Open Position	CW - Increase CCW - Decrease
P2	Opening Speed	CW - Increase CCW - Decrease

The ASSA ABLOY Group is the global leader in access solutions. Every day we help people feel safe, secure and experience a more open world.



ASSA ABLOY

Technical Product Support:
Monroe, NC 28112 USA
Phone: 877.974.2255 ext: 2
Techsupport.NortonRixson@assaabloy.com
NortonRixson.com

Norton Rixson is a brand associated with ASSA ABLOY Accessories and Door Controls Group, Inc., an ASSA ABLOY Group company. Copyright © 2010, 2014, 2019, 2023, ASSA ABLOY Accessories and Door Controls Group, Inc. All rights reserved. Reproduction in whole or in part without the express written permission of ASSA ABLOY Accessories and Door Controls Group, Inc. is prohibited.

Approved 2023-11-13

80-9357-0140-020 Rev 4 11/23