

6011/6021 LAP Replacement Installation Instructions

⚠ WARNING

This product can expose you to lead which is known to the state of California to cause cancer and birth defects or other reproductive harm. For more information go to www.P65warnings.ca.gov.

Pour la version française voir www.nortondoorcontrols.com.
READ AND FOLLOW ALL INSTRUCTIONS. SAVE THESE INSTRUCTIONS.

6011/6051 Unit (Pull Side)

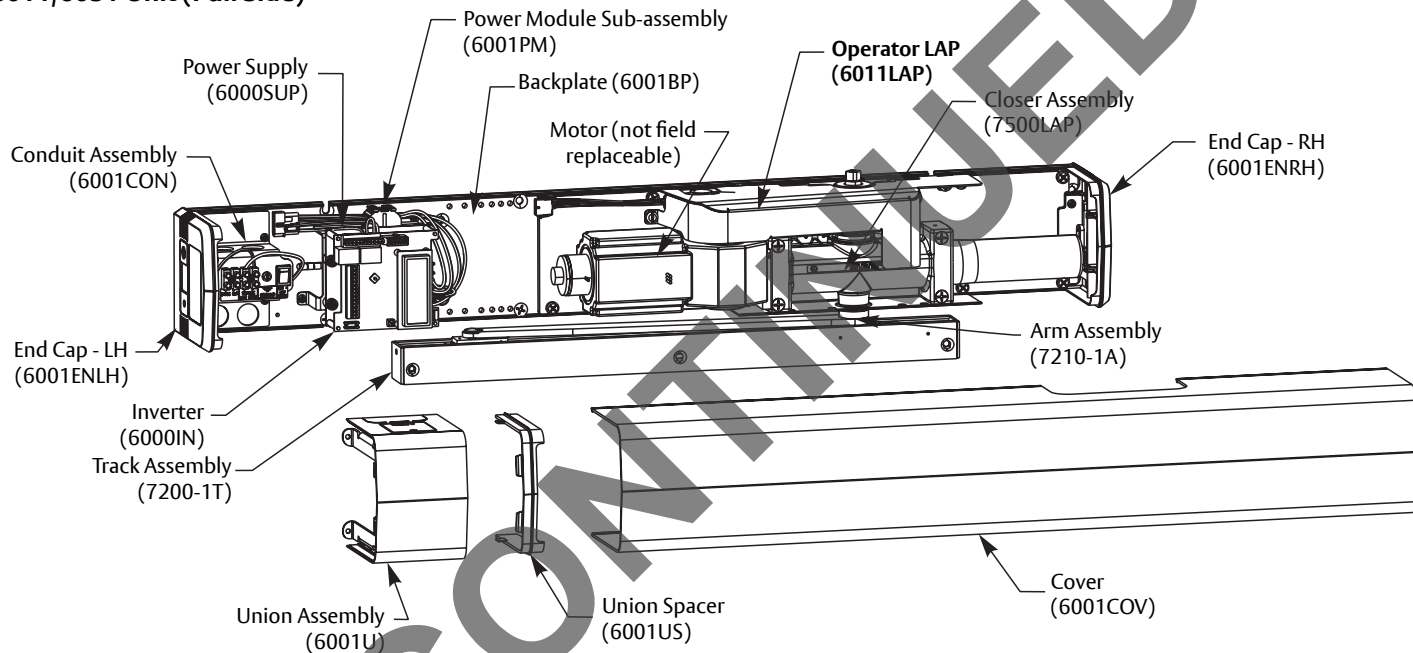

6021/6031/6061/6071 Unit (Push Side)

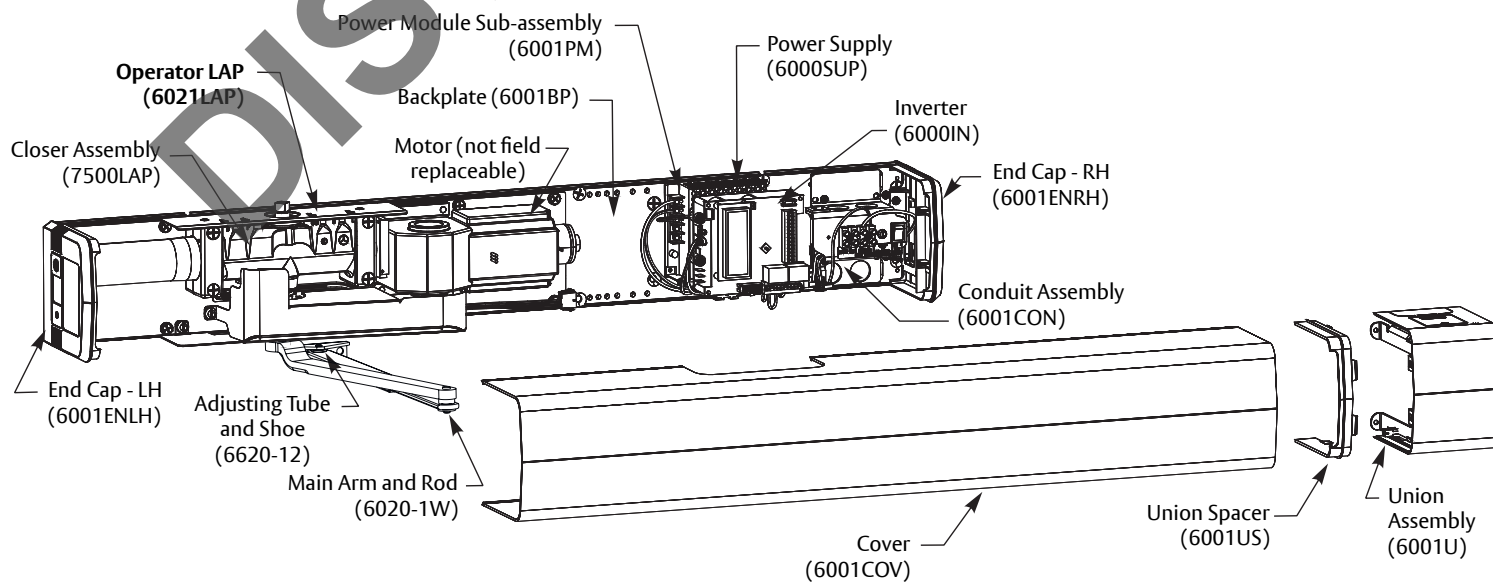

Prepare Unit for Replacement Operator LAP

A. Turn off control of door.

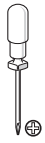

1. Open union assembly access door and flip selector mode switch to OFF position. (Figure 1)

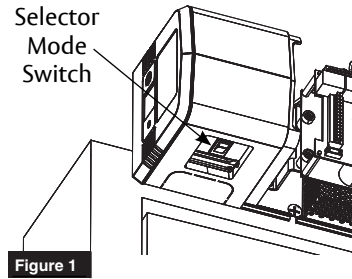

B. Remove Cover.

1. Grasping at locations shown, pull cover off of unit. (Figure 2)



NOTE:

- Cover is not secured with screws.
- Take care not to pull union assembly or end caps which are secured with screws.

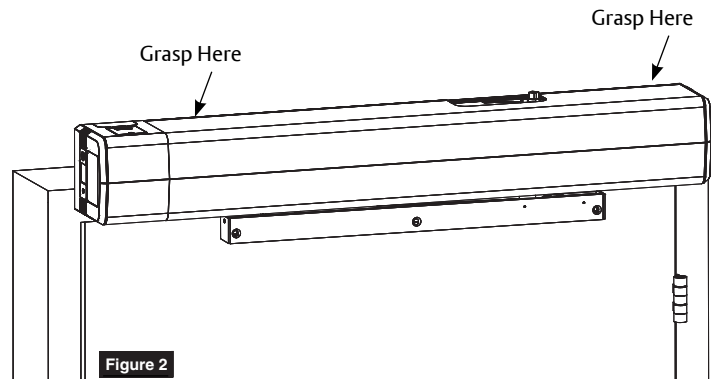

C. 6011/6051 PULL Unit: Disconnect Arm from Pinion.



1. Open door.
2. Using a flat blade screw driver, pull out clip in track slider. (Figure 3)
3. Pull up slightly on arm so arm stud comes out of slider. (Figure 3)

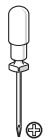

CAUTION: Arm will immediately start to move toward door frame.

4. Remove screw and countersunk washer using a Phillips screw driver. (Figure 4)
5. Using an adjustable wrench, rotate top pinion 45 degrees toward door hinge and hold. (Figure 5)
6. Slide arm off pinion and release adjustable wrench.

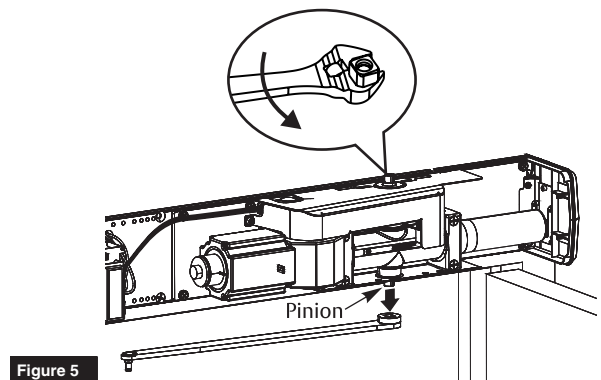
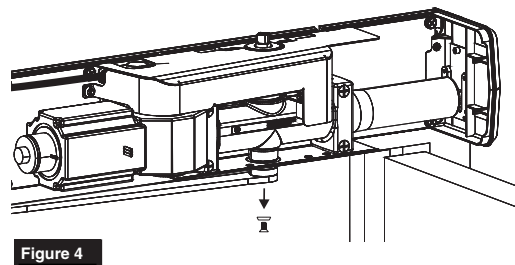
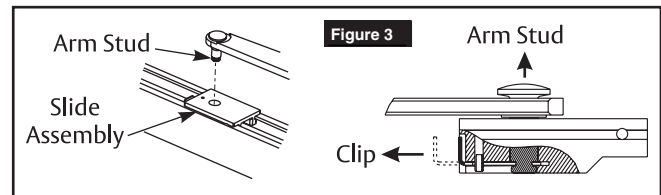

C. 6021/6031/6061/6071 PUSH Unit: Disconnect Arm from Pinion.

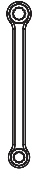

1. Open door.
2. Using 7/16" wrench, remove pinion screw holding main arm on pinion. (Figure 6)
3. Using 7/16" wrench, loosen forearm screw in main arm rod and adjusting tube so that main arm can slide out of tube. (Figure 7)



CAUTION: Arm will immediately start to rotate.

4. When pinion and main arm rotate so main arm is perpendicular to door, slide main arm off of pinion.

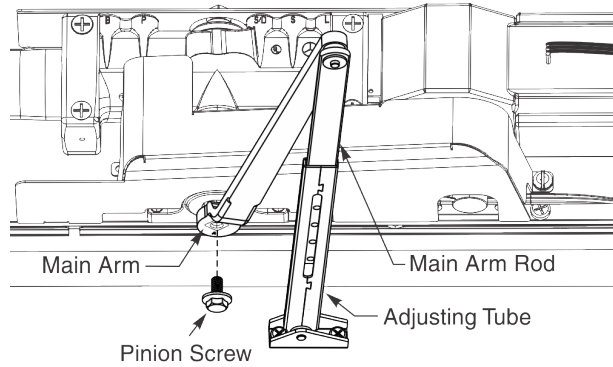

Figure 6 6021/6031 Arms Shown

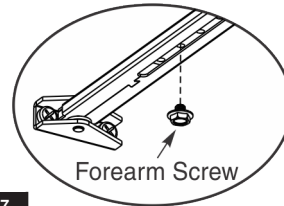

Figure 7

D. Turn off power to unit.

1. Turn On/Off switch to OFF position on conduit assembly. (Figure 8)

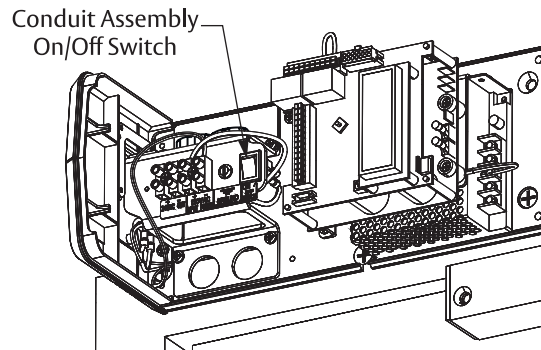

Figure 8 Union Assembly and Spacer not shown

Replace Operator LAP

A. Disconnect Operator LAP from Power Module Sub-assembly.

1. Detach 10-pin black connectors between operator LAP and power module sub-assembly. (Figure 9)
2. Detach 3-pin white connectors between operator LAP and power module sub-assembly. (Figure 9)

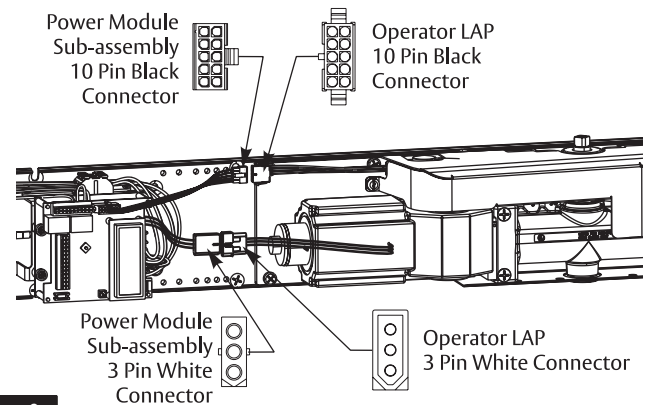

Figure 9

B. Remove Operator LAP.

1. Remove six (6) screws securing LAP to backplate. (Figure 10)
2. Loosen two (2) protruding screws and lift LAP off of unit. (Figure 11)

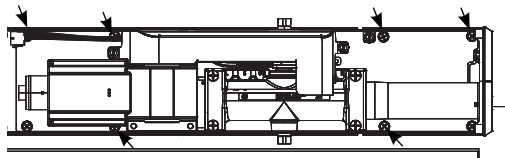
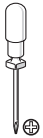

Figure 10 6 LAP Mounting Screws

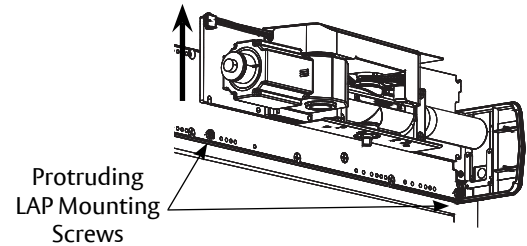
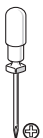

Figure 11

C. Install Replacement Operator LAP.

1. Orienting LAP so spring tube of closer is pointed toward hinge edge of frame, slide LAP over two (2) protruding screws and tighten. (Figure 11)
2. Using six (6) 1/4-20 x 1/2" Phillips head screws, secure LAP to backplate. (Figure 10)



NOTE: Holes in LAP align with threaded holes in backplate.

NOTE: Screws to be torqued to 80 in-lb minimum.

D. Connect Operator LAP and Power Module Sub-assembly.

1. Attach 10-pin black connectors between operator LAP and power module sub-assembly. (Figure 9)
2. Attach 3-pin white connectors between operator LAP and power module sub-assembly. (Figure 9)

NOTE: Connectors are keyed and only attach one way.

Reconnect Arm

6011/6051 PULL Unit



1. Open door.
2. Using an adjustable wrench, rotate top pinion 45 degrees toward door hinge. You will feel resistance from spring. (Figure 12)
3. While holding pinion at 45 degrees, slide arm on bottom pinion parallel to frame as shown. (Figure 12)

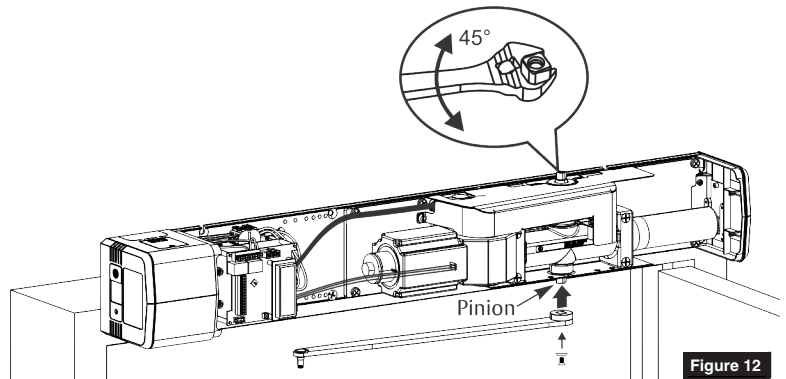
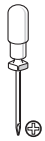

Figure 12



NOTE: Pinion flat should be aligned as shown. (Figure 13)



4. Secure arm to pinion with 1/4-20 x 1/2" screw and countersunk patch washer. (Figure 12)
5. Insert stud on arm into slider in track by pressing clip on backside of slider onto stud. (Figure 14)

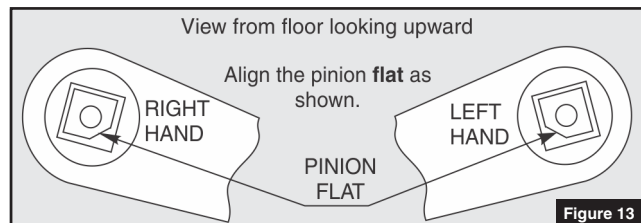

Figure 13



6. To adjust track stop:
 - Use allen wrench to loosen set screw in bumper stop.
 - Open door to full open position.
 - Slide bumper stop until it just touches end of slider.
 - Tighten set screw in bumper stop so bumper will stay in position. (Figure 15)

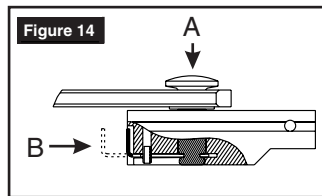

Figure 14

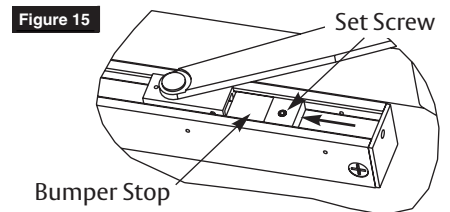

Figure 15

6021/6031/6061/6071 PUSH Unit



1. Place square of main arm onto closer pinion. (Figure 16)



NOTE: Pinion flat should be aligned as shown. (Figure 17)

2. Attach main arm to pinion with pinion screw and tighten with 7/16" wrench. (Figure 16)
3. With door closed, rotate main arm away from hinge until adjusting tube is perpendicular (90 degrees) with door. (Figure 18)
4. While holding arm in position, secure rod to adjusting tube with forearm screw. (Figure 19)

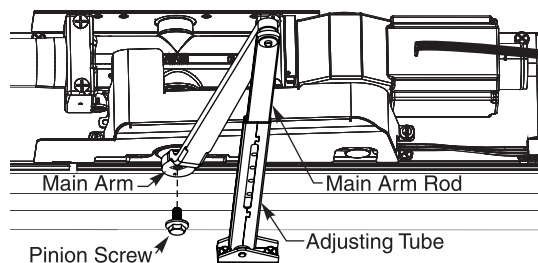

Figure 16 6021/6031 Arms Shown

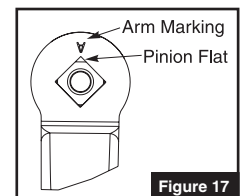

Figure 17

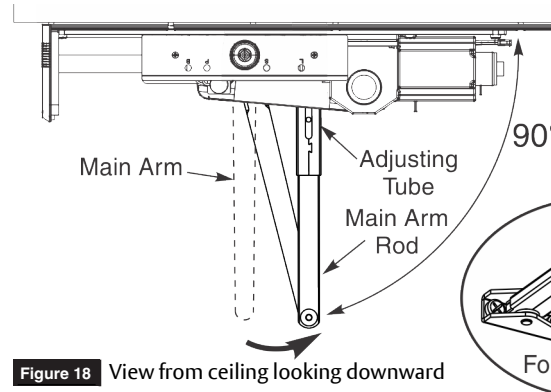

Figure 18 View from ceiling looking downward

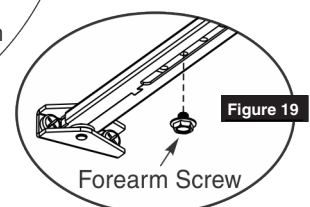

Figure 19

Adjustments

A. Adjust mechanical closer features.

NOTE:

- Make necessary mechanical adjustments so unit functions as a standard surface mounted door closer before adjusting spring force, applying power, adding accessories or making electrical/programming adjustments.

- Valve location S/D is not adjustable.
- Chain protection plate cutouts allow access to valves. Use hex wrench to make adjustments (Figure 20)

! Do not remove valves from closer. Hydraulic oil will escape.

1. Closing Speed Controls (Figure 20)
 - Valve "S" controls Sweep Range from full open to 10°.
 - Valve "L" controls Latch Range from 10° to closed.
2. Opening Cycle (Figure 20)
 - Valve "B" controls strength of cushioning in Backcheck Range.

! **NOTE: NEVER close Backcheck valve completely – it is not to provide a positive stop.**

- Valve "P" adjusts angle that backcheck is felt in open cycle. Factory preset is typically acceptable.

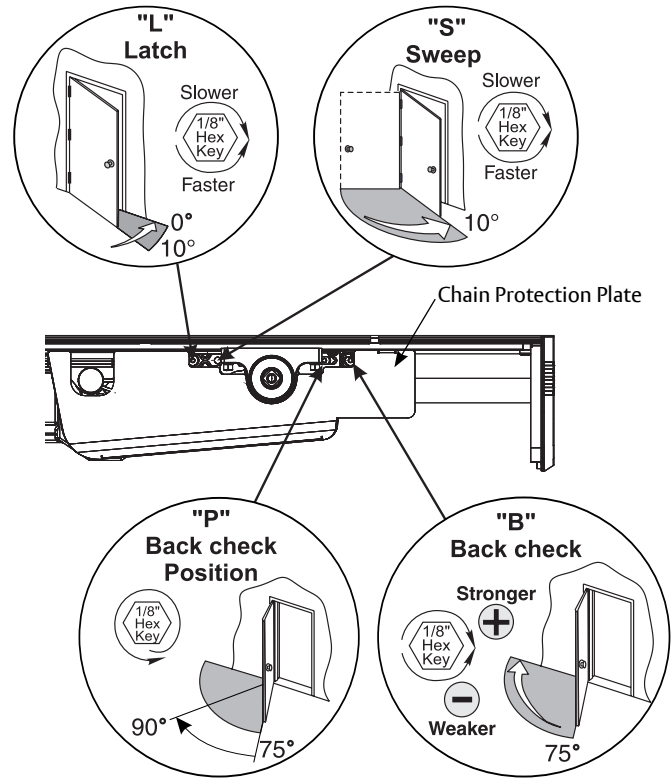

Figure 20 View from ceiling looking down

B. Adjust spring force.

NOTE:

- The amount of effort to manually open or close a door is called force and is controlled by the operator's closer spring.
- Make necessary mechanical adjustments described in "A" above.
- A closer set to ADA required 5 lbs opening force may not be strong enough to close door due to latching hardware, air pressure, or frame issues.

1. Using 11/16" wrench, turn nut in end of closer body tube to desired force. (Figure 21)

NOTE: If spring adjustment nut is too close to end cap and wrench will not reach nut, remove Torx screw in end cap access door and slide door open. When finished, slide access door closed and reinsert #6 Torx flat head screw to secure door. (Figure 21)

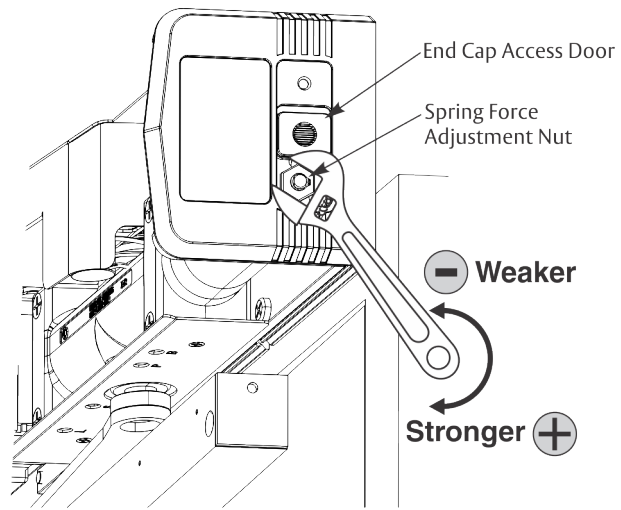
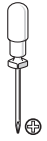

Figure 21

Power Operator



1. Turn on building power.
2. Turn On/Off switch to "ON" position on conduit assembly. (Figure 22)



WARNING: Door may begin to move immediately when power is applied. An open union assembly door on a PULL unit has potential to pinch fingers if hand is not withdrawn quickly when switching on power. (Figure 24)

- To scroll through menu items, push up or down on joystick. (Figure 22)
- To change setting of a menu item, when cursor is on that item, push joystick right to increase or left to decrease value.

NOTE: Values will auto-save 3 seconds after adjustments.

3. Set 'HOME' procedure for door.
 - With door closed and selector mode switch of union assembly in "OFF" position, use joystick to scroll down menu on LCD screen to "Home".
 - Push in on joystick to activate menu feature. Display changes to "Set Close Limit".
 - Push in on joystick again, while door is still closed, to set Home or closed position (Figure 23). Display changes to "Set Open Limit".
 - Open door to desired open position (Figure 23) and push in on joystick again. Display changes to "Closing to Home".
 - Allow door to fully close again (Figure 23). Display changes to "Home".

NOTE: Values will auto-save.

4. Make necessary adjustments to inverter and add required accessories.
5. Place selector mode switch of union assembly in 'ON' position for activation by push plate, RF button, or other activation devices. Place switch in 'H/O' for continuous hold open. (Figure 24) Secure union assembly door with #4 Phillips screw when finished.



WARNING: Door may begin to move immediately when selector mode switch is changed. An open union assembly door on a PULL unit has potential to pinch fingers if hand is not withdrawn quickly when adjusting switch. (Figure 24)

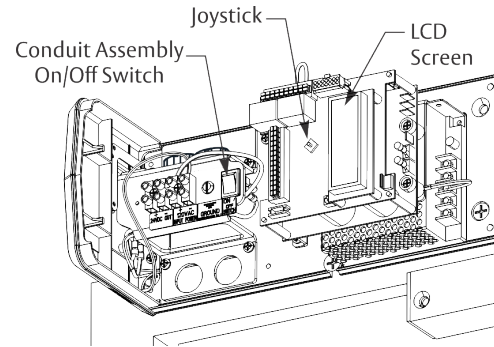

Figure 22 Union Assembly and Spacer not shown

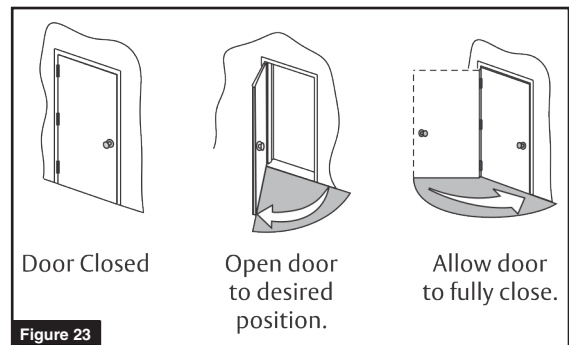

Figure 23

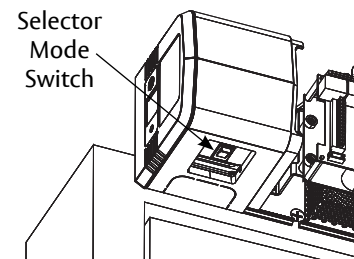

Figure 24

The ASSA ABLOY Group is the global leader in access solutions. Every day we help people feel safe, secure and experience a more open world.

Attach Cover to finalize installation

1. Align cut-outs in cover to pinion shafts. (Figure 25)
2. Slide cover onto unit using end cap and union spacer as guides.

NOTE: Verify all wiring and sheet metal guards are inside cover.

3. Snap cover securely to backplate. Pull on cover to verify it is secure.

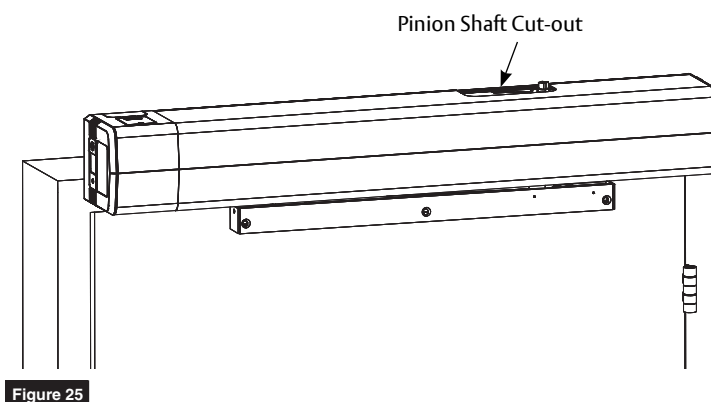

Figure 25



WARNING: Make sure no wiring is loose or can be caught by cover when it is snapped into place.

You've now replaced the **6011 or 6021 Operator LAP.**

Norton Technical Product Support:
Monroe, NC 28112 USA
Phone: 800.438.1951 ext: 6030
TechSupport.Norton@assaabloy.com
nortondoortcontrols.com

Norton is a brand associated with ASSA ABLOY Accessories and Door Controls Group, Inc., an ASSA ABLOY Group company. Copyright © 2019, ASSA ABLOY Accessories and Door Controls Group, Inc. All rights reserved. Reproduction in whole or in part without the express written permission of ASSA ABLOY Accessories and Door Controls Group, Inc. is prohibited.

Approved

80-9360-1034-020 Rev 1 10/19
Note: Later approved revision exists