

DOOR INSTALLATION

Top Door Rail ("A" Type End Loading Arm)

- Make a 3/4" (19) deep cutout on edge of door as shown.
- Drill or drill and tap holes in top of door as shown.
- Position arm in door by placing arm pin in 3/16" (4.8) hole. Install arm using three 1/4-20x3/4" panhead machine screws and lockwashers. Center arm in the top rail by adjusting the two 1/4-20x1" hex head centering bolts.

NOTE: After door is installed: the two 1/4-20x1" socket head clamp bar cap screws with lockwashers must be tightened securely.

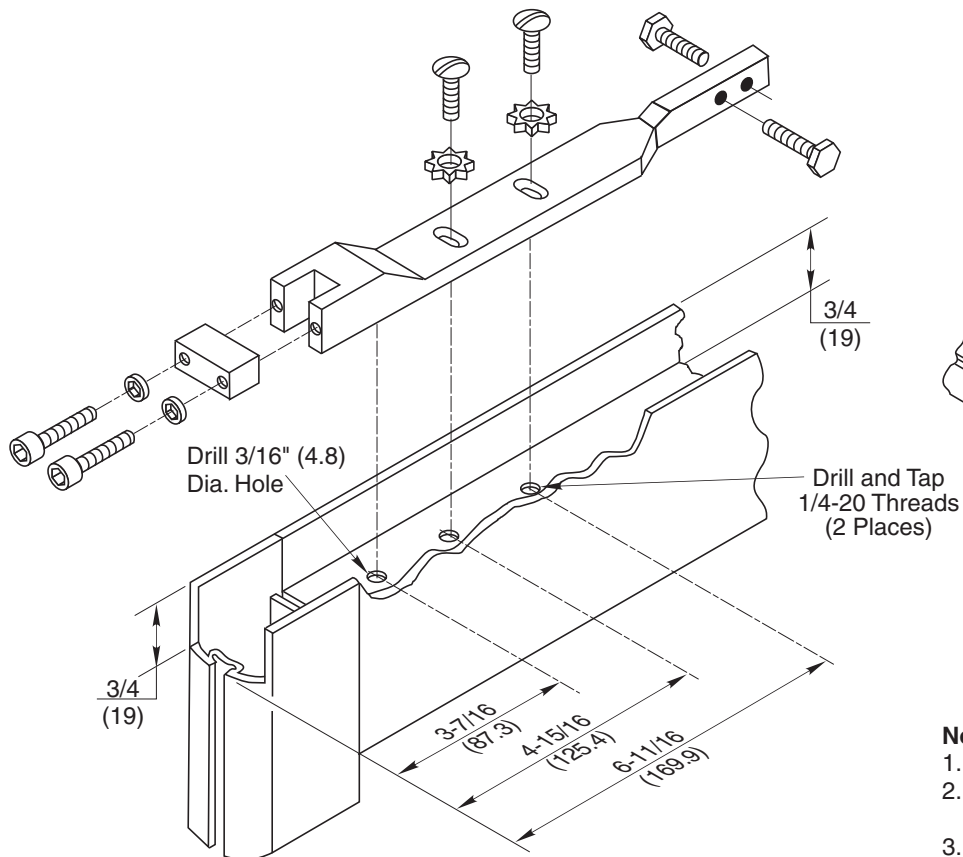

Bottom Door Rail (End Loading)

- Make cutout on edge of door equal to depth of bottom rail as shown.
- Drill and tap 1/4-20 holes in top of door as shown. Install pivot bearing retainer in bottom of door using two 1/4-20x3/4" pan head machine screws and lockwashers.
- Laterally adjust center of pivot bearing retainer 2-5/8" (66.7) from outside edge of door (not including weatherstripping) and tighten screws firmly.

NOTE: For doors with 1" (25.4) bottom rail depth, pivot stud must be shortened by sawing off at score 1/2" (12.7) from bottom.

Mount	Dim. "A"
Threshold	1-9/16 (39.7)
Floor	2-1/16 (52.4)

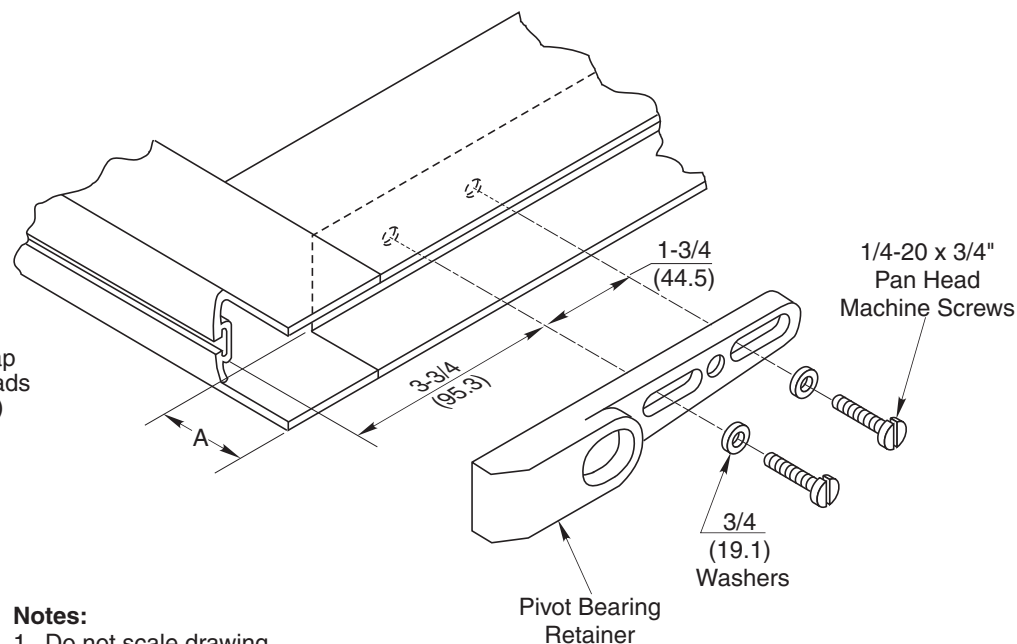

Notes:

1. Do not scale drawing.
2. Double or single acting, center hung and end loading.
3. Door radius recommended 2-5/8" (66.7).
4. All dimensions given in inches (mm).

608 Series Concealed Overhead Door Closers Double or Single Acting Aluminum Doors & Frames Center Hung, End Loading



ASSA ABLOY

TEMPLATE NUMBER	REV	DATE
OC60420A	3	01/22