

NOTES:

- Do not scale drawing.
- Left hand door shown.
- Hardware dimensions shown (not cutout).
- Dimensions are in inches. Metric = 25.4 x inch.
- Minimum thickness recommended for reinforcements in hollow metal doors and frames: .1046" (2.66mm.) unless otherwise noted.
- Minimum door width 27" (686mm).
- Track is 24" (610mm) long.
- Maximum width hinge is 5" (127).
- Door can swing to 180 degrees conditions permitting.

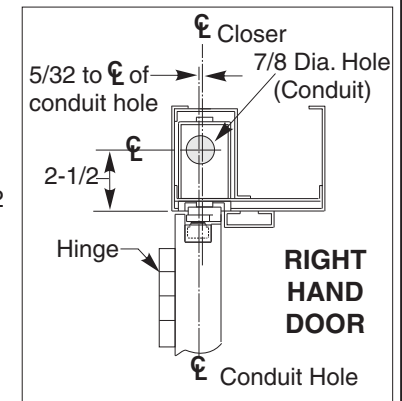
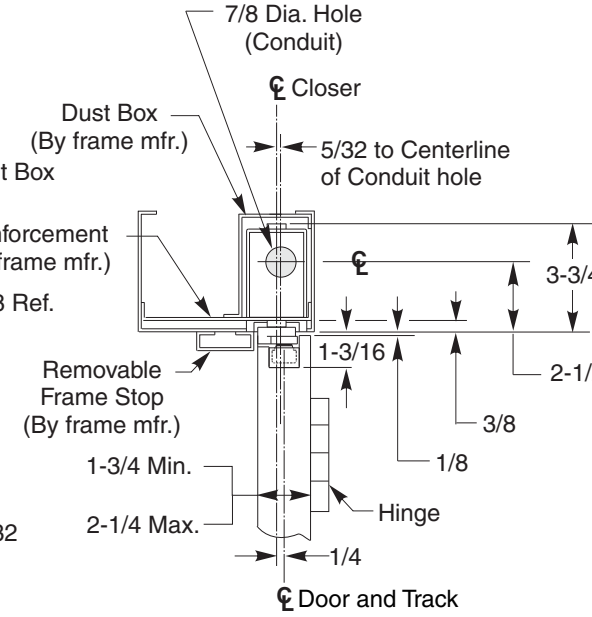

Fastener	Use	⊕ Preparation
1/4-20 machine screw	metal frame and metal door	#7 (.201" dia.) Drill 1/4-20 tap
#14 wood screw	wood door	7/32" Drill

**7290MPS x 790 Fire Bloc Series Combination Door Closer
 Holder and Releasing Device
 Overhead Concealed Closer with Rigid Slide Arm
 Door Closer Assembly Mounted in Hollow Metal Frame
 For Use on Doors Hung on 5" Wide Butt Hinges (max.)**



TEMPLATE NUMBER	REV	DATE
7372-1291	3	02/22