

CAUTION TO PREVENT ELECTRICAL SHOCK AND EQUIPMENT DAMAGE, DISCONNECT ALL POWER BEFORE BEGINNING. MAXIMUM WIRE SIZE IS 18 AWG. ALL WIRING MUST COMPLY WITH APPLICABLE LOCAL ELECTRICAL CODES, ORDINANCES, AND REGULATIONS. **CAUTION**

Combination Door Closer-Holder and Releasing Device with or without Integral Smoke Detector

Wiring Instructions

Electromechanical Releasing Device with Multi-Point Hold-Open

**INSTALLER:
LEAVE
INSTRUCTIONS WITH
BUILDING OWNER**

Electromechanical Series

Primary Unit
Support Unit

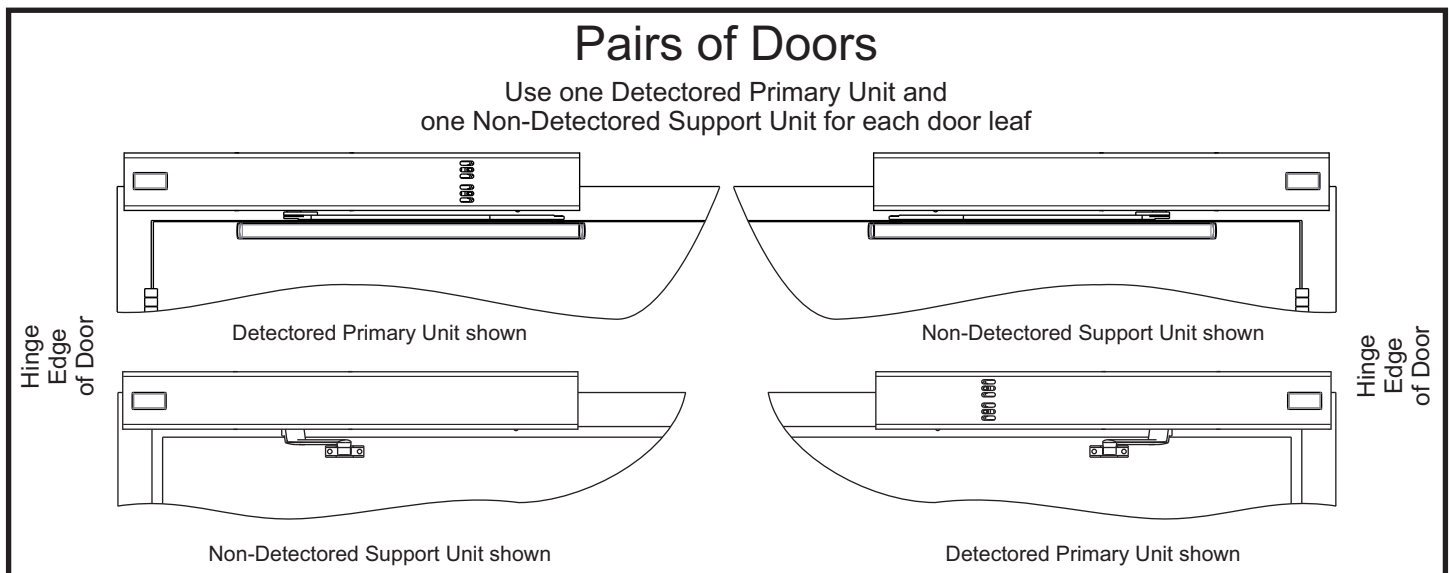
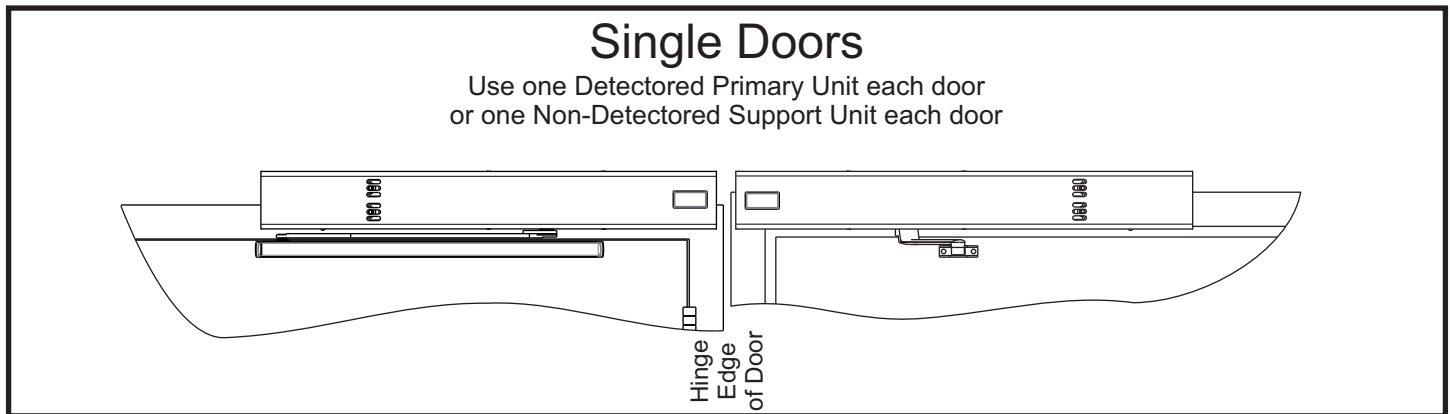

CAUTION:

1. Failure to install or adjust properly may result in injury or damage.
2. Disconnect all power before beginning installation to prevent electrical shock and equipment damage.
3. All wiring must comply with applicable local electrical codes, ordinances, and regulations.
4. Maximum wire size is 18AWG.
5. These units are not to be used in limited open area applications.

REQUIREMENT:

Power input to unit must be of the same voltage as that listed on the product label:

- **24VDC** for systems where the power input to both the integral smoke detector and the door holder solenoid is supplied from the same circuit (see Pages 4 and 6 thru 8 of these instructions).

Unit Examples:

Electromechanical Series:

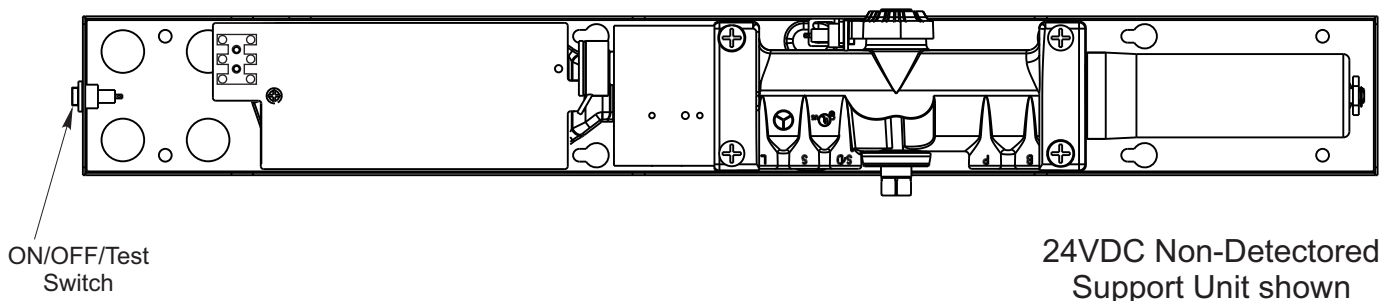
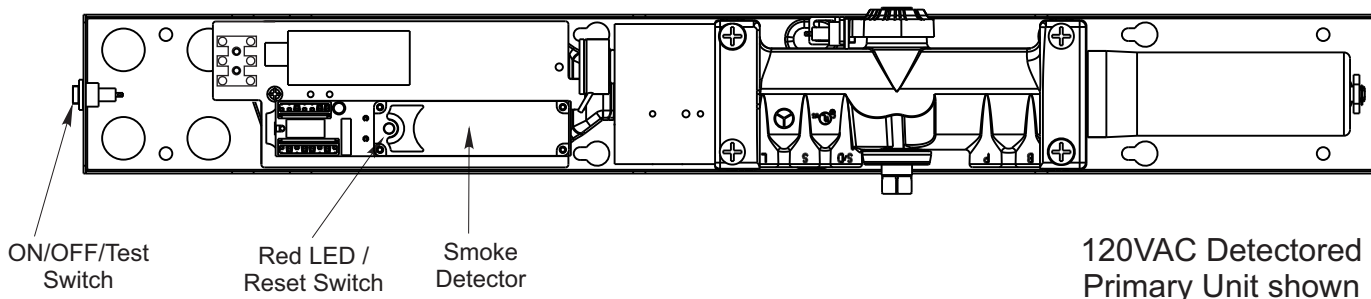

WARNING:



- Life safety devices require correct positioning and appropriate selection for the required task. It is the responsibility of the purchaser to select appropriate hardware and provide professional installation. It is the responsibility of the purchaser to insure that NFPA and other applicable fire codes are met. Door release devices function properly only if the door is free to close and is installed correctly.
- Smoke detectors will not work without power. AC or DC powered smoke detectors will not work if the power supply is cut off for any reason.
- These fire protection devices require correct wiring to function. Devices wired incorrectly may be damaged and therefore not covered under warranty.
- All high voltage wiring should be undertaken by a qualified professional licensed electrician. It is the responsibility of the purchaser to insure that installation meets all applicable local and national electrical codes.
- A detector may not detect a fire developing on another level of a building. For this reason, detectors should be located on every level of the building.
- Smoke detectors will not sense fires which start where smoke does not reach the detectors. Smoke from fires in chimneys, in walls, on roofs, or on the other side of a closed door may not reach the smoke detector and activate it.
- Smoke detectors cannot last forever. Smoke detectors contain electronic parts. Even though detectors are made to last over 10 years, any of these parts could fail at any time. Therefore, test your smoke detector system per NFPA 72 Chapter 10 at least semiannually. Clean and take care of your smoke detectors regularly. Refer to Page 5 of these instructions for "Smoke Detector Cleaning and Testing". Taking care if the fire detection system you have installed will maintain the reliability of the system.
- Smoke detectors have sensing limitations. Smoke detectors used in high air velocity conditions may fail to alarm due to dilution of smoke densities created by such frequent and rapid air exchanges. Additionally, high air velocity environments may create increased dust contamination, demanding more frequent maintenance.

Smoke Detector Terminal Inputs and Outputs

- 24V input power is applied to terminals 3 (-) and 14 (+) from the circuit board. The red LED flashes every 8 seconds.
- Terminals 1 and 2 provide a normally open (alarm) contact. This contact closes when smoke is detected. The red LED illuminates continuously.
- Terminals 5 and 13 provide a normally closed supervisory (trouble) contact. This contact opens when power is lost to the detector circuitry. The red LED stops flashing and does not illuminate.
- Terminals 6 and 9, if used, provide rectified, unfiltered 24VDC power to an additional door holder solenoid. In an alarm condition, power is removed and the door closes.
- Terminals 7 and 8, if used, provide rectified, unfiltered 24VDC power to auxiliary devices when the detector alarms.
- Terminal 10 is 24VDC Positive output. It is continuous, rectified, unfiltered 24VDC power used for remote detector interconnect applications.
- Terminals 4 and 15 provide interconnections to other detectors (see diagram on Page 8). Up to five smoke detectors may be interconnected. When a single detector alarms, terminal 15 goes high and all interconnected smoke detectors will release their doors. The unit that initiated the alarm will have its LED on. The LED on the other interconnected units will flash as normal. Refer to Interconnection Wiring Diagram for connections.

CONNECTION LIST

FUNCTION	TERMINAL
24VDC input	3 (-), 14 (+)
Alarm Contacts	1, 2
Latch (+)	9
Latch (-)	6
Aux (+)	8
Aux (-)	7
Interconnect (+)	15
Interconnect (-)	4
SOLENOID (+)	9
Trouble contacts	13, 5
+24VDC output (unfiltered)	10

NOTE: Terminals 4, 6, and 7 are same point

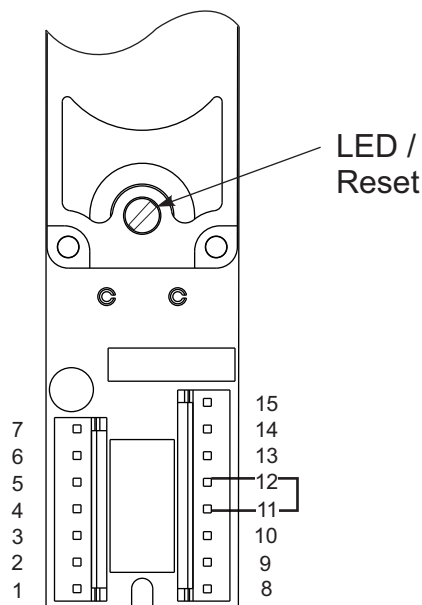

Detector Specifications:

- Type: Photo-Electric Smoke Detector complies with UL 228 and UL 268 standards.
- Power Requirements: 24VDC +/- 10%.
- Normal Sensitivity: 2.325 +/- 1.055% / FT.
- Contact Ratings:
 - Alarm and / or accessories (Resistive Load):
 - 2.0 Amps Max @ 24VDC
 - 0.6 Amps Max @ 120VAC
 - Trouble Contact (Resistive Load):
 - 0.5 Amps Max @ 24VDC

	Max / Min Voltage	Current - Detector
24 VAC	26.4 VAC Max	0.028 A Standby 0.059 A Alarm
	21.6 VAC Min	
24 VDC	26.4 VDC Max	0.034 A Standby 0.074 A Alarm
	21.6 VDC Min	
120 VAC	132 VAC Max	0.033 A Standby 0.036 A Alarm
	106 VAC Min	

Checking Procedures:

- Turn the power to the unit “On”. Red LED light should illuminate at 8 second intervals.
- Open the door to the hold open point. The door should hold open. Manually pull door out of hold open and release. The door should close.
- Open the door to the hold open position. Press the Test / Reset Switch button on the power supply board. Door should close.
- Press the Test / Reset Switch button again. Open the door to the hold open position. Inducing smoke into the smoke detector chamber assembly will bring the unit into alarm. The red LED will be continuously illuminated and the door will close. After clearing the smoke chamber, reset the unit as described below.

Resetting Instructions:

- **Remote Reset:** Cycle main power by turning the facility main power supply OFF then ON. NOTE: If there are other units connected to the same power supply, those doors will close. They will have to be reopened returning them to the hold open position.
- **Local Reset:** Insert a small flat head screwdriver through the cover and into the slotted light tube on the smoke detector as shown. Turn screwdriver slightly (about 1/8 turn) **clockwise** until hitting stop and hold for 2 seconds until the Red LED turns OFF. **WARNING: Do not force past the stop. Doing so may damage the smoke detector.**

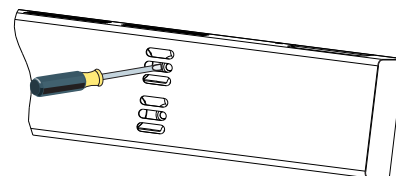

Once the detector is reset and the smoke has cleared, the detector’s Red LED should flash once every 8 seconds. The door(s) should hold open now.

Maintenance of Smoke Detectors:

It is recommended to clean smoke detectors at least every six months. The frequency of cleaning will depend upon local ambient conditions.

The smoke detector in this door closer-holder has been enhanced with a feature that detects when a smoke-sensing chamber requires cleaning due to dirt and dust. The need for cleaning is indicated by the flashing of the Red LED once per second.

- Normal Supervisory Operation - Red LED flashes once every 8 seconds.
- **Dirty Chamber needs cleaning** - Red LED flashes once every second.
- **Smoke Detection** - Red LED is continuously illuminated.

To clean the smoke detector assembly, follow these instructions: (NOTE: Before servicing the system, notify the proper authorities that the smoke detector system is undergoing maintenance and will be temporarily out of service. Disable the zone undergoing maintenance to prevent unwanted alarms.)

- Remove detector cover and screen assembly using a standard screwdriver. Turn the screwdriver in the cover slot to loosen the cover and carefully rock the cover back and forth until it snaps out of place. See slot location below.
- Inspect chamber for particles and dust. Vacuum the screen, cover, and photo chamber. Then use clean, compressed air to loosen and blow out any remaining debris.
- Before reassembling the detector, be sure all parts are free of dust and debris.
- Replace cover and screen, aligning cover snaps. Press cover onto chamber until it snaps into place.
- Measure and record the test voltage at test points **RP1** and **RP2** (see below).
- If the smoke detector is operating normally and was cleaned effectively, the **test voltage** will be greater than .90VDC and less than **1.58VDC**. The test voltage will increase with dust accumulation in the smoke sensing chamber. A difference in test voltages over time will provide an indication of dust accumulation.
- Enable the system and inform proper authorities that system is operational.

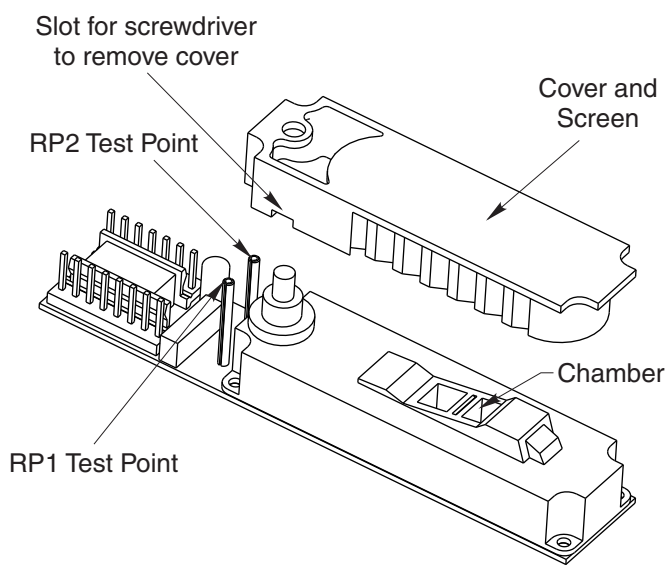

PRIMARY WIRING DIAGRAM FOR 4-WIRE (CLASS A) SYSTEM WITH ALARM PANEL MONITORING

- The alarm circuit monitors if smoke is detected
- The detector trouble circuit monitors if power is lost to the detector.

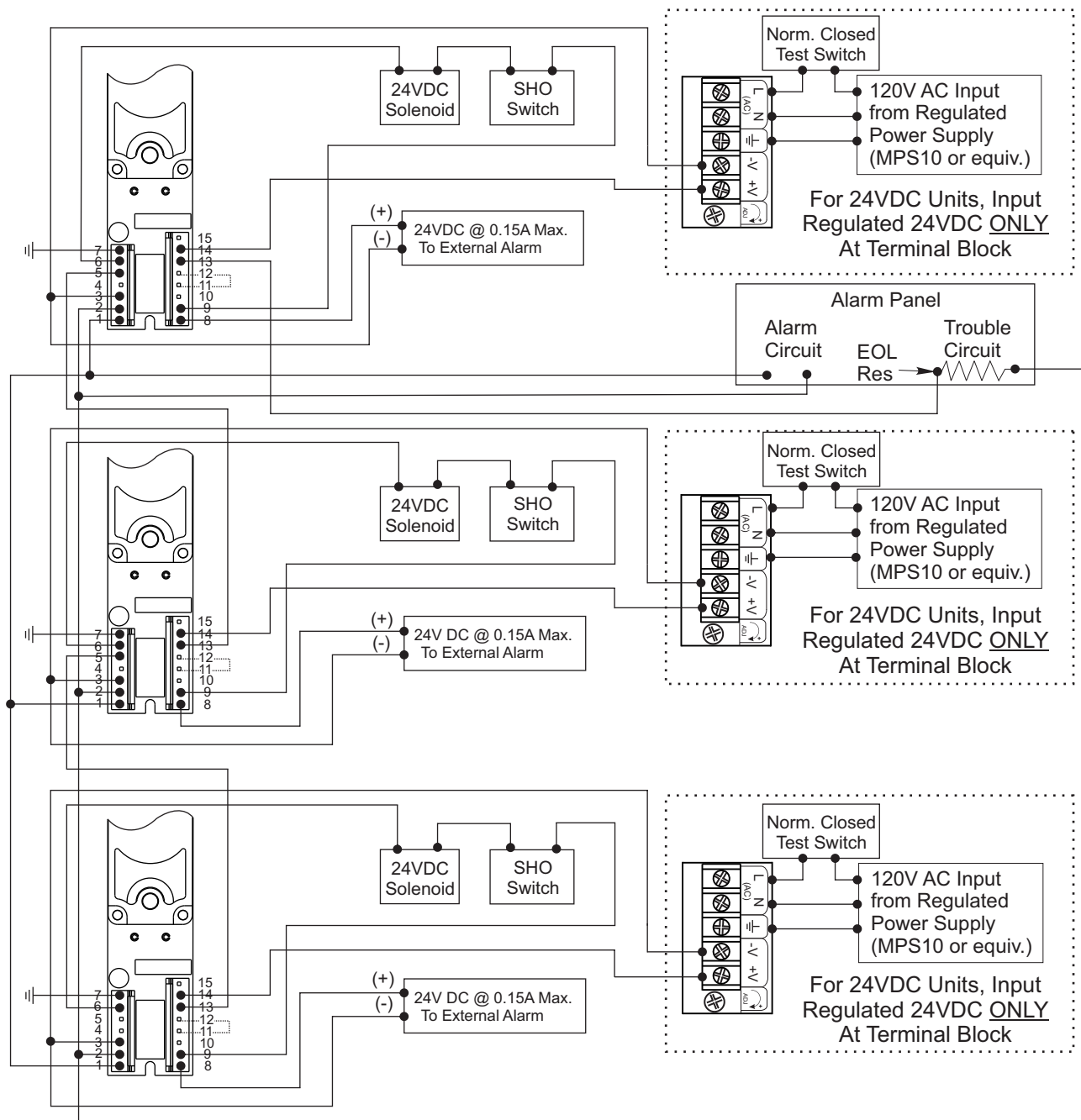

Notes:

- End of Line (EOL) resistor determined and supplied by others.
- Terminal numbers shown correspond to position numbers of terminal strips on detector.
- Additional units may be added as required based on this schematic. See electrical data sheet. Do not overload circuits.
- All wiring connections use standard wiring practice conforming to local wiring codes.

PRIMARY WIRING DIAGRAM FOR 2-WIRE (CLASS B) SYSTEM WITH ALARM PANEL MONITORING

- The alarm circuit and trouble circuit monitor if smoke is detected

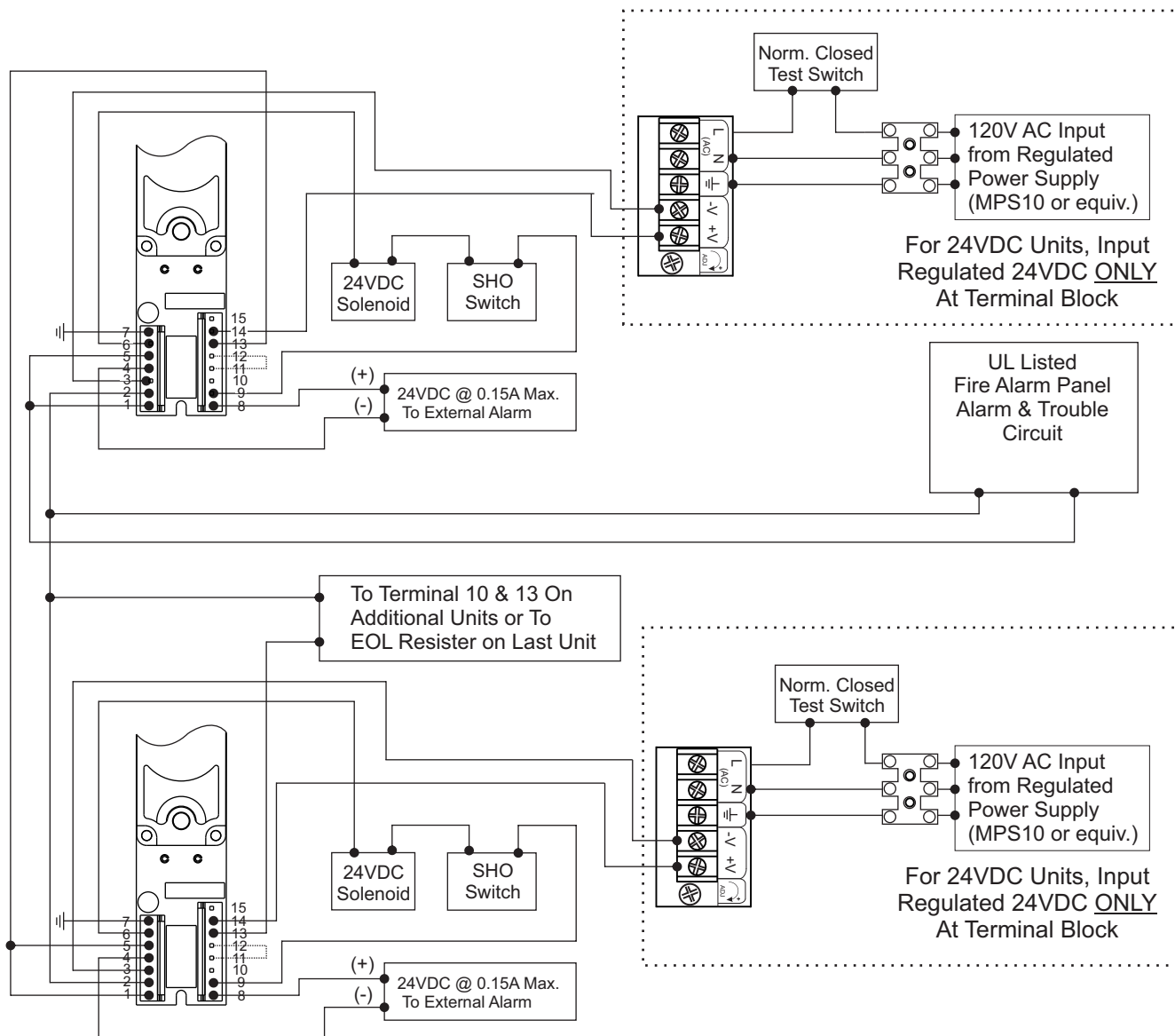

Notes:

- End of Line (EOL) resistor determined and supplied by others.
- Terminal numbers shown correspond to position numbers of terminal strips on detector.
- Additional units may be added as required based on this schematic. See electrical data sheet. Do not overload circuits.
- All wiring connections use standard wiring practice conforming to local wiring codes.

Wiring Diagram for Primary to Companion

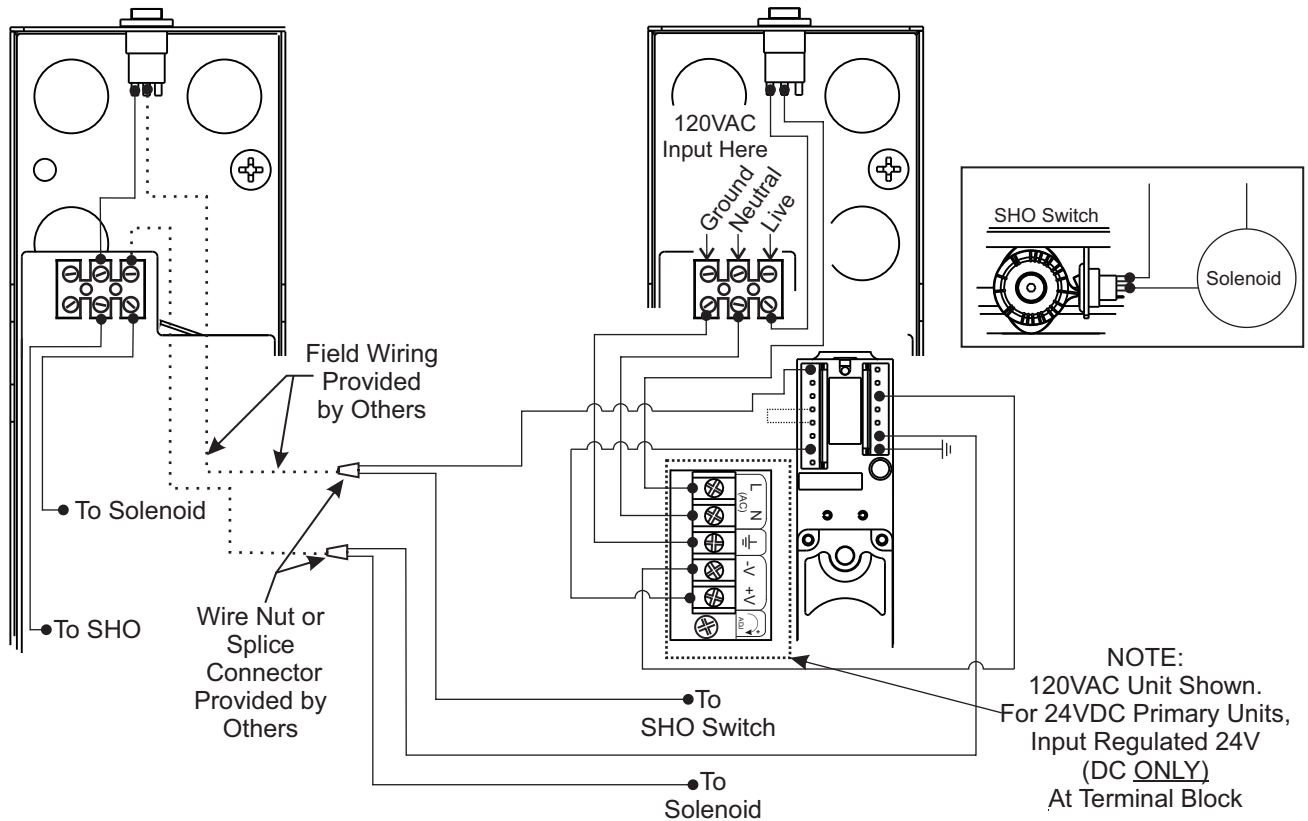

Interconnection Wiring Diagram

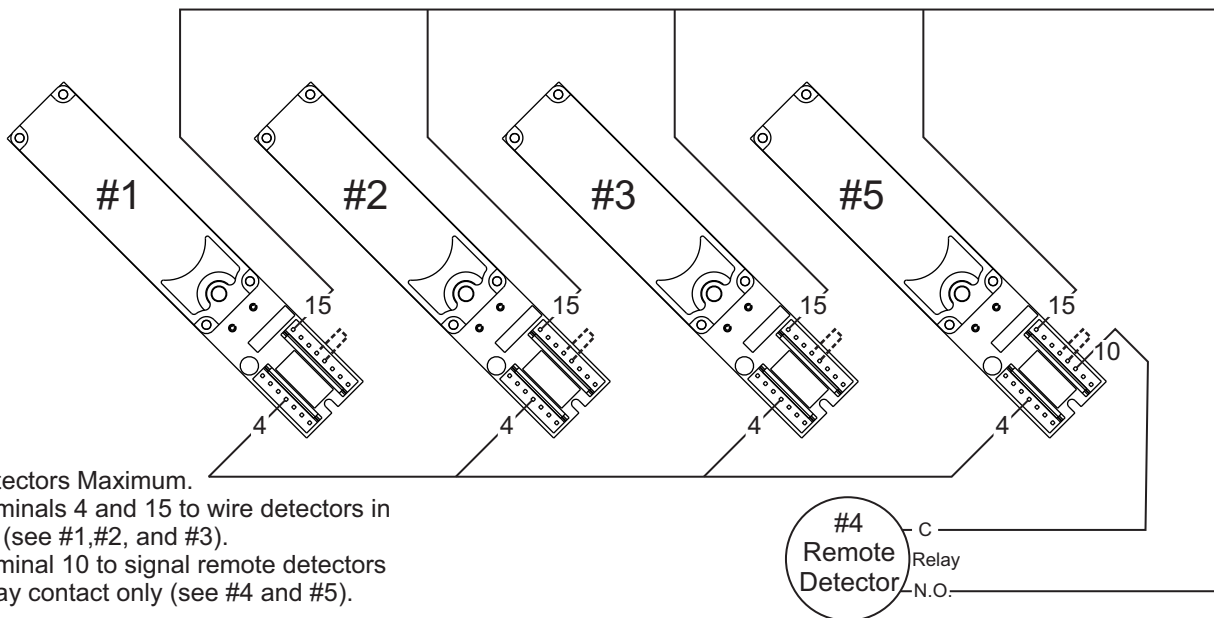

Notes:
Five Detectors Maximum.
Use Terminals 4 and 15 to wire detectors in parallel (see #1, #2, and #3).
Use Terminal 10 to signal remote detectors with relay contact only (see #4 and #5).

Norton Technical Product Support:
Monroe, NC 28112 USA
Phone: 800.438.1951 ext: 6030
TechSupport.Norton@assaabloy.com
nortondoорcontrols.com

Norton is a brand associated with ASSA ABLOY Accessories and Door Controls Group, Inc., an ASSA ABLOY Group company.
Copyright © 2012, 2020, ASSA ABLOY Accessories and Door Controls Group, Inc. All rights reserved. Reproduction in whole or in part without the express written permission of ASSA ABLOY Accessories and Door Controls Group, Inc. is prohibited.

Experience a safer
and more open world
80-9372-0904-000 (08-20)