

# 7500SS Series Door Closer

Non Hold Open  
Regular, Top Jamb and Parallel Arm  
Installation Instructions

# Multi Size 1-6

7500SS  
J7500SS  
JL7500SS  
P7500SS



ASSA ABLOY

## ! WARNING

This product can expose you to lead which is known to the state of California to cause cancer and birth defects or other reproductive harm. For more information go to [www.P65warnings.ca.gov](http://www.P65warnings.ca.gov).

**CAUTION**  
An incorrectly installed or improperly adjusted door closer can cause property damage or personal injury. These instructions should be followed to avoid the possibility of misapplication or misadjustment.  
**CAUTION**

- With or without suffix "DA" (Delayed Action) closing.

**Note:**  The closing force for series 7500 door closer is adjustable from a size 1 to a size 6, as outlined in ANSI Standard A156.4. When this series of door closer is installed and adjusted to conform to ADA reduced opening force requirements (5 lbs max.) for interior doors, it may not have adequate closing force to reliably close and latch the door. Power adjustments charted on pages 3,4 and 5 are recommended where possible, to ensure proper door control.

For Special Applications a separate door and frame preparation template is packed with these instructions. Use this instruction sheet for installation sequence and closer adjustments only.

### Regular Arm Installation

Closer mounts on hinge (pull) side of door.

See Page 3.

Closer cover not shown

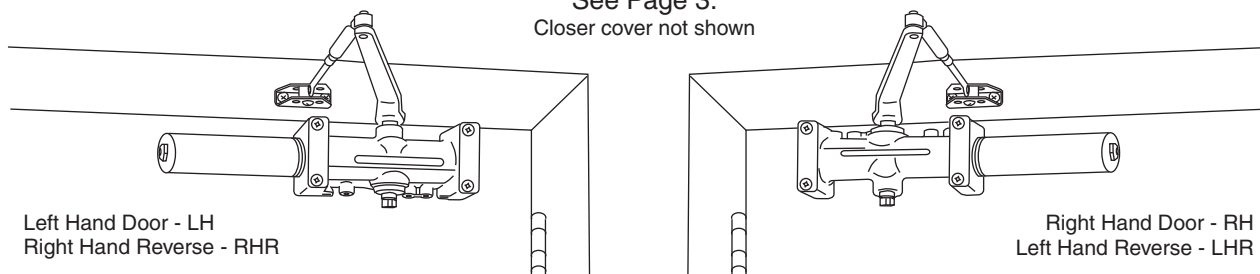

### Top Jamb Installation

Closer mounts on frame face on opposite to hinge (push) side of door.

See Page 4.

Closer cover not shown

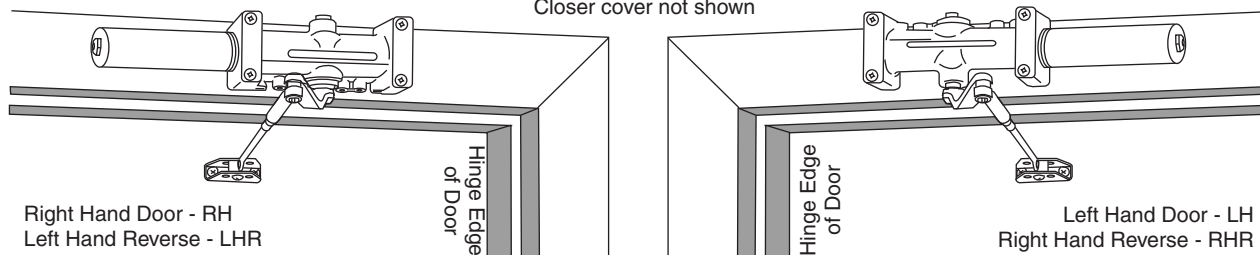

### Parallel Arm Installation

Closer mounts on opposite to hinge (push) side of door.

See Page 5.

Closer cover not shown

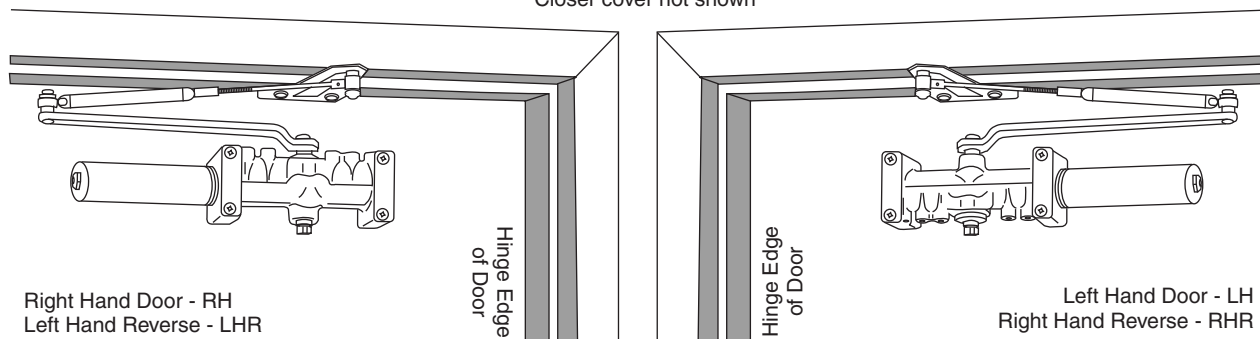

**Components:**

**Figure 1**

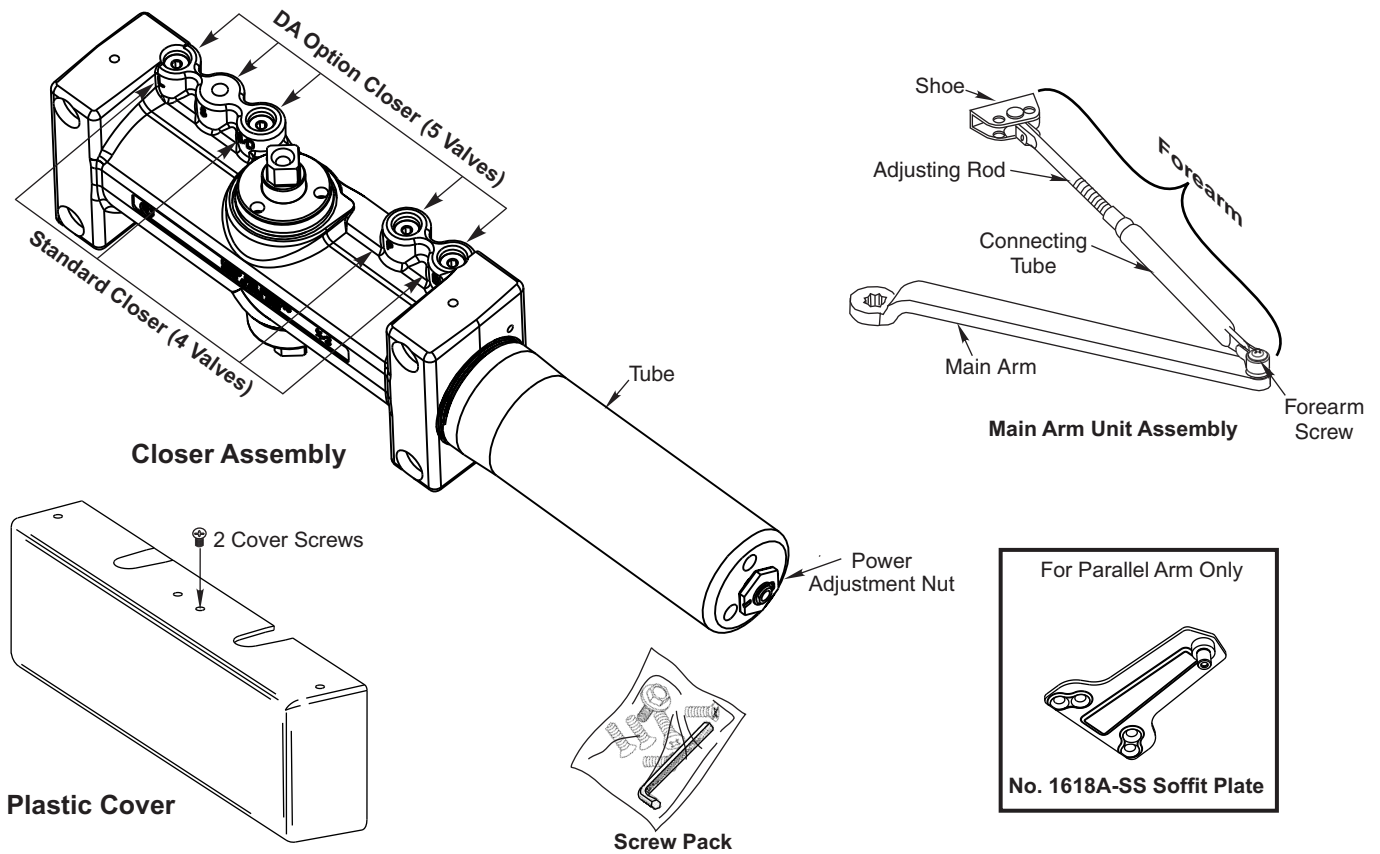

- It is recommended that the door, on which the door closer will be installed, be hung on ball bearing hinges. Door must swing freely.
- A separate door stop, supplied by others, is recommended to prevent damage to the door closer, closer arm; or to the door, frame or adjacent walls.
- Door and Frame must be properly reinforced, or use of special fasteners employed, to prevent the mounting screws from pulling out.
- All dimensions are given in inches with corresponding metric dimensions (millimeters) in parentheses.
- Door closer should never be installed on the exterior of a building.

Preparation for Fasteners (Figure 2)			
	Fasteners	Door or Frame	Drill-Sizes
Standard	1/4" - 20 machine screw	Aluminum	Drill: #7 (0.201" dia.) Tap: 1/4" - 20
	#14 type "A" S. M. Screw	Wood (see Note)	7/32" (5.56mm)
	1/4" - 20 machine screw	Metal	Drill: #7 (0.201" dia.) Tap: 1/4" - 20
Optional	Sleeve nuts and bolts	Hollow Metal	9/32" (7 mm) through; 3/8" (9.5 mm) door face opposite to closer
		Aluminum or Wood	3/8" (9.5 mm) through
	Through-bolts and grommet-nuts	All	9/32" (7 mm); 3/8" (9.5 mm) dia. x 3/8" (9.5 mm) deep on door opposite to closer

**Note:** Wood doors/frames. Pilot hole must be drilled when using Self-Drilling Screws.

Always consult door/frame manufacturer for fastener compatibility with the material of their door/frame.

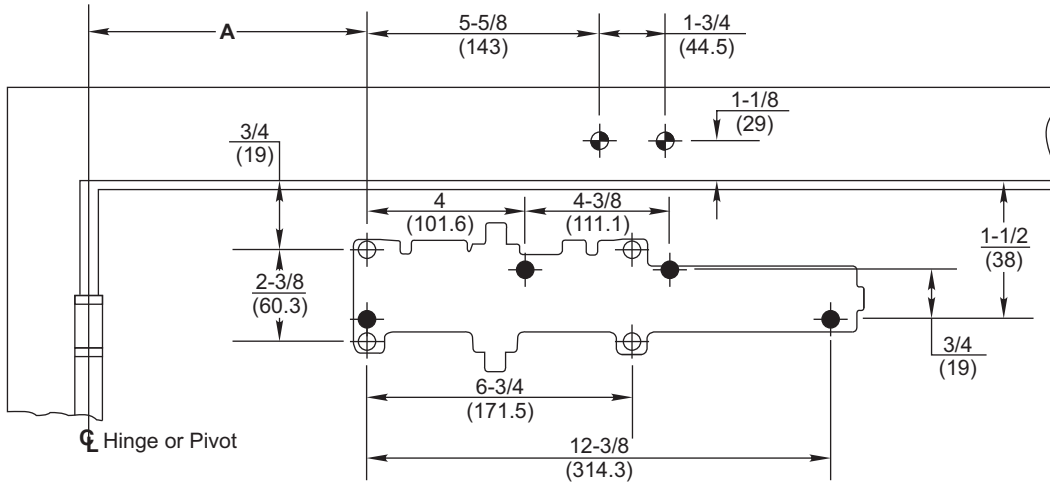

Do Not Scale Drawing  
 Right Hand Door Shown  
 Dimensions are in inches (mm).

● 7786SS Backplate Mounting Hole Only

Opening	Dimension A	
	inches	mm
To 100°	7-5/8	194
101° to 120°	6-5/8	168
121° to 150°	4-5/8	117
151° to 180°	4-1/8	105

## Installation Sequence

- Select angle of opening and use dimensions shown in template and chart to locate 4 holes ⊕ on door for closer body (or 4 holes ● for optional 7786SS backplate) and 2 holes ⊕ on frame face for arm shoe.
- For applications that are different from above, a separate template will be supplied for door and frame preparation.

- Prepare door and frame for fasteners using "Preparation for Fasteners" chart, Figure 2, Page 2.
- Fasten optional 7786SS backplate to door, only if it is required for the door conditions.
- Install closer body with tube end **away** from hinge, with valves:  
 Down for Left Hand door  
 UP for Right Hand door.
- Remove forearm screw from elbow joint and disassemble arm, see Figure 1, Page 2. Fasten arm shoe (forearm) to frame face.
- Install main arm onto closer pinion shaft, aligning arm mark "S" with the one flat corner of the square shaft "Pinion Flat", see illustration at right. Secure with hex head main arm screw and flat washer.

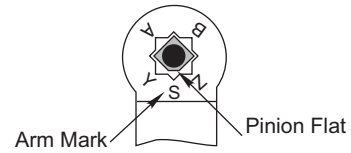

- Close door and adjust forearm length so that the forearm is perpendicular (at a 90° angle) to the door when it is connected to the main arm. Install and tighten forearm screw and washer.

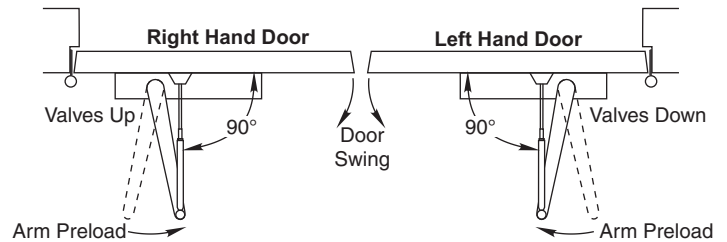

- Make closer adjustments, if required, using information below and on Page 6, then install closer cover.

Power Adjustment Chart		
Maximum Interior Door Size inches / (mm)	Maximum Exterior Door Size inches / (mm)	Turns from Zero
32 / (813)	28 / (711)	5
36 / (914)	34 / (864)	8-1/2
42 / (1067)	38 / (965)	11
52 / (1321)	42 / (1067)	13-1/2
60 / (1524)	48 / (1219)	16-1/2

NOTE: Maximum of 16-1/2 turns (360°) of Power Adjustment Nut.

Install closer per instructions with the proper pre-load applied to the arm then adjust spring power. The power adjustment will not work properly if the closer spring is not pre-loaded. To increase power, use 11/16" wrench to turn power adjustment nut clockwise. To decrease power, turn nut counter clockwise.

**DO NOT use a power drill or driver to turn adjustment nut. This will damage closer and void warranty.**

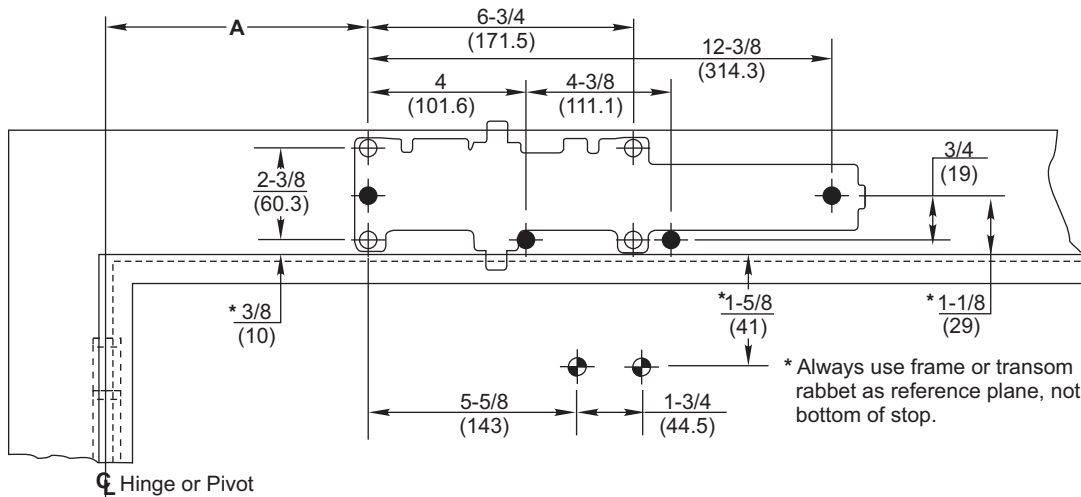

Do Not Scale Drawing

Left Hand Door Shown

Dimensions are in inches (mm).

● 7786SS Backplate Mounting Hole Only

Opening	Dimension A	
	inches	mm
To 100°	7-5/8	194
101° to 120°	6-5/8	168
121° to 150°	4-5/8	117
151° to 180°	4-1/8	105

**Installation Sequence**

- Select angle of opening and use dimensions shown in template and chart to locate 4 holes ⊕ on frame for closer body (or 4 holes ● for optional 7786SS backplate) and 2 holes ● on door for arm shoe. For applications that are different from above, a separate template will be supplied for door and frame preparation.

- Prepare door and frame for fasteners using "Preparation for Fasteners" chart, Figure 2, Page 2.
- Fasten optional 7786SS backplate to frame, only if it is required for the frame conditions.

- Install closer body with tube end **away** from hinge, with valves:  
Up for Left Hand door  
Down for Right Hand door.

- Remove forearm screw from elbow joint and disassemble arm, see Figure 1, Page 2. Fasten arm shoe (forearm) to door. Note that a longer adjusting rod or different arm might be required for your frame conditions, see illustration with "reveal range chart" to the right.

- Install main arm onto closer pinion shaft, aligning arm mark "S" with the one flat corner of the square shaft, "Pinion Flat", see illustration at right. Secure with hex head main arm screw and flat washer.

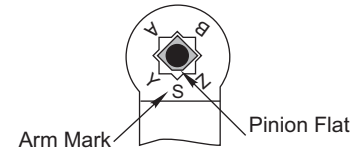

- Close door and adjust forearm length so that the forearm is perpendicular (at a 90° angle) to the door when it is connected to the main arm. Install and tighten forearm screw and washer.

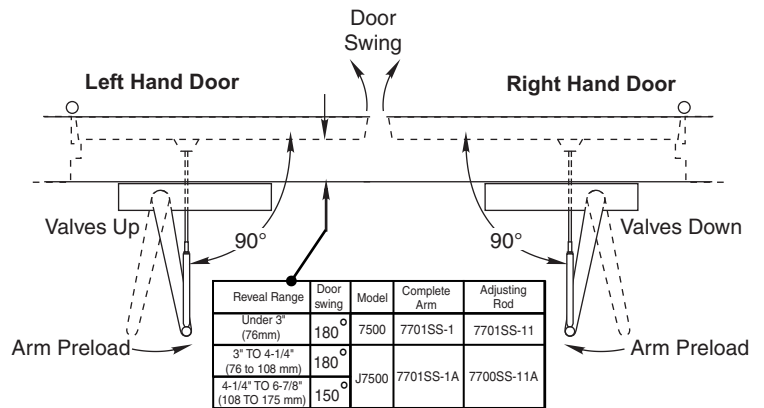

- Make closer adjustments, if required, using information below and on Page 6, then install closer cover.

Power Adjustment Chart		
Maximum Interior Door Size inches / (mm)	Maximum Exterior Door Size inches / (mm)	Turns from Zero
32 / (813)	28 / (711)	5
36 / (914)	34 / (864)	8-1/2
42 / (1067)	38 / (965)	11
52 / (1321)	42 / (1067)	13-1/2
60 / (1524)	48 / (1219)	16-1/2
NOTE: Maximum of 16-1/2 turns (360°) of Power Adjustment Nut.		

**Install closer per instructions with the proper pre-load applied to the arm then adjust spring power. The power adjustment will not work properly if the closer spring is not pre-loaded. To increase power, use 11/16" wrench to turn power adjustment nut clockwise. To decrease power, turn nut counter clockwise.**

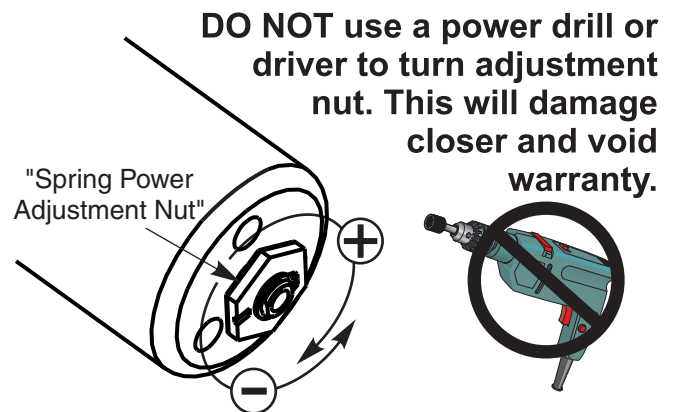

# 7500SS Series (Parallel Arm Mount)

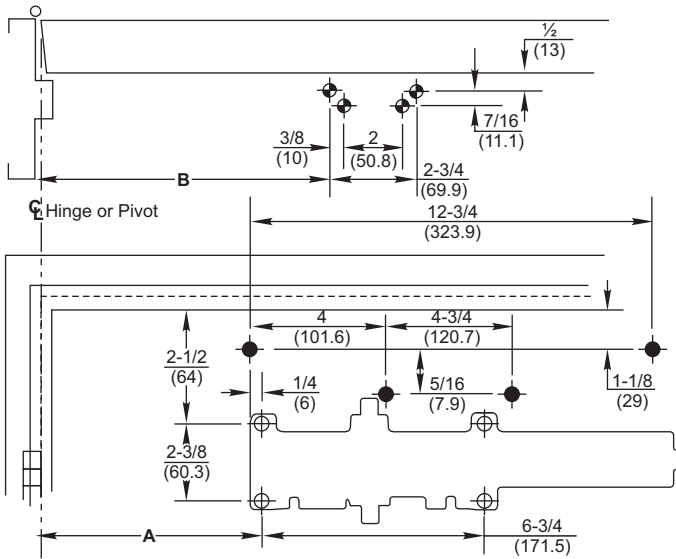

Opening	Dimension A		Dimension B	
	inches	mm	inches	mm
To 100°	8-3/4	222	9-1/4	235
101° to 130°	7-1/4	184	7-3/4	197
131° to 150°	6-1/4	159	6-3/4	171
151° to 180°	5-1/4	133	5-3/4	146

Do Not Scale Drawing  
Left Hand Door Shown  
Dimensions are in inches (mm).

● 7788SS Droplate  
Mounting Hole Only

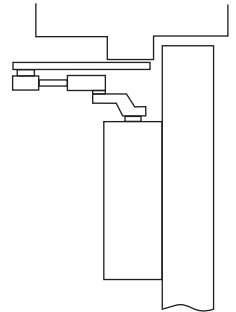

## Installation Sequence

- Select angle of opening and use dimensions shown in template and chart to locate 4 holes ⊕ on door for closer body (**or 4 holes ● for optional 7788SS droplate**) and 4 holes ⊕ on underside of frame for soffit plate.
- For applications that are different from above, a separate template will be supplied for door and frame preparation.
- Prepare door and frame for fasteners using "Preparation for Fasteners" chart, Figure 2, Page 2.
- Fasten optional 7788SS backplate to door, only if it is required for the door conditions.
- Install closer body with tube end away from hinge, with valves:  
Down for Left Hand door  
UP for Right Hand door.
- Fasten soffit plate to frame.
- Remove forearm screw from elbow joint, and disassemble shoe unit, see Figure 1, Page 2. Fasten forearm (adjusting rod end) to soffit plate on frame using screw and washer assembly from screw pack.
- Install main arm onto closer pinion shaft following instructions below. The one flat corner of the square shaft "Pinion Flat", must be aligned with the corner mark on arm:

Arm mark "Y" for Right Hand door  
Arm mark "Z" for Left Hand door

• Secure with hex head main arm screw and flat washer.

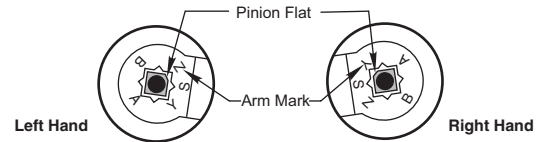

- Close door and pull main arm away from door face so that elbow is 1-1/2" (38mm) off of door face. Adjust Forearm length and reassemble onto main arm. Install and tighten forearm screw and washer.

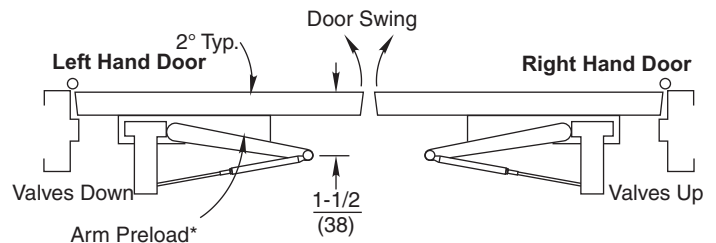

- Make closer adjustments, if required, using information below and on Page 6, then install closer cover.

Power Adjustment Chart		
Maximum Interior Door Size inches / (mm)	Maximum Exterior Door Size inches / (mm)	Turns from Zero
30 / (762)	26 / (660)	7
34 / (864)	30 / (762)	9
38 / (965)	36 / (914)	12-1/2
48 / (1219)	42 / (1067)	14-1/2
54 / (1372)	48 / (1219)	16-1/2
NOTE: Maximum of 16-1/2 turns (360°) of Power Adjustment Nut.		

**Install closer per instructions with the proper pre-load applied to the arm then adjust spring power. The power adjustment will not work properly if the closer spring is not pre-loaded. To increase power, use 11/16" wrench to turn power adjustment nut clockwise. To decrease power, turn nut counter clockwise.**

**DO NOT use a power drill or driver to turn adjustment nut. This will damage closer and void warranty.**

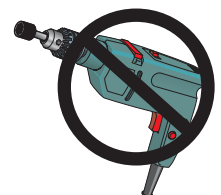
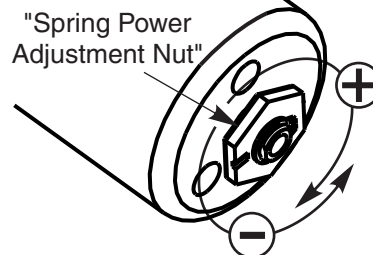

The ASSA ABLOY Group is the global leader in access solutions. Every day we help people feel safe, secure and experience a more open world.

## Adjustments

### Closing Speed Controls (Figure 4A or 4B and 5.)

- Valve "S/D" Controls Sweep Range on Standard closer (or Delayed Range on Delayed Action closer).
- Valve "L" Controls Latch Range.
- Valve "S" Controls Sweep only on Delayed Action closer.

### Closing Power Control Figure 3

Set closer to desired size. For recommended sizes, refer to the Power Adjustment Chart on pages 3,4,& 5.

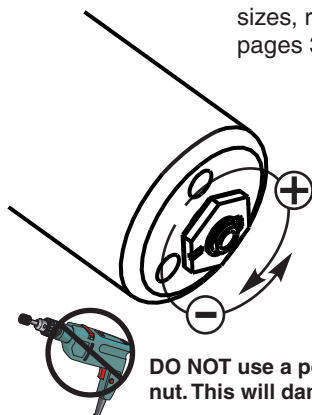

Install closer per instructions with the proper pre-load applied to the arm then adjust spring power. The power adjustment will not work properly if the closer spring is not pre-loaded. To increase power, use 11/16" wrench to turn power adjustment nut clockwise. To decrease power, turn nut counter clockwise.

**DO NOT use a power drill or driver to turn adjustment nut. This will damage closer and void warranty.**

### Closing Speed Controls Figure 4

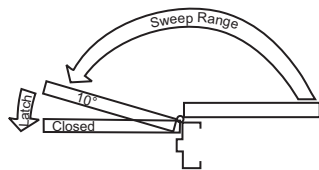

Standard Closing Cycle **4A**

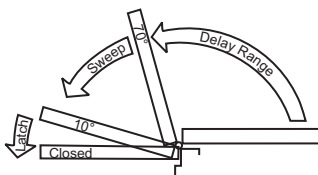

Delayed Action Closing Cycle **4B**

Adjust Closing Speed Time to between 3-7 seconds from 90°. Use of door by handicapped, elderly or small children may require greater closing time.

### Closing Speed Controls Figure 5

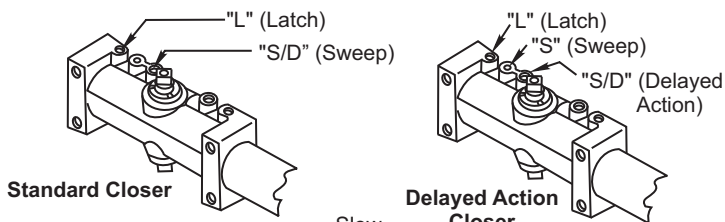

Do not force valves counter-clockwise out of closer body or a fluid leak will occur.

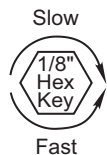

All Valves

### Opening Door Control (Figure 6.)

- Backcheck ("B") valve controls the hydraulic resistance to door opening. NEVER close this valve completely – it is not to provide a positive stop.
- Backcheck position ("P") valve controls the door angle where backcheck cushioning starts. Valve normally closed.

### Opening Door Controls Figure 6

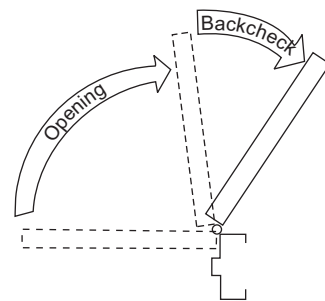

Opening Cycle

### Backcheck Figure 7

#### Backcheck Position



Open for backcheck later in door-opening cycle.

#### Backcheck Cushion Increase

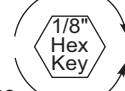

Decrease

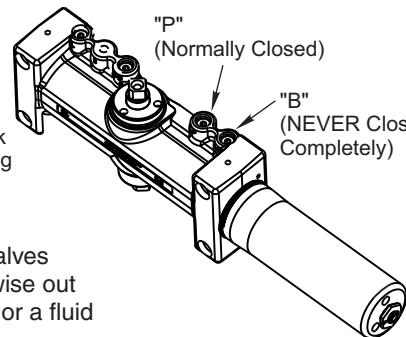

Do not force valves counter-clockwise out of closer body or a fluid leak will occur.

### Identify Door Closer

Standard 7500 = 4 valves (S/D, L, P&B)  
Delayed Action 7500DA = 5 valves (S/D,S,L, P&B)

Older models may be stamped "1-6", "1-4" or "2-6". They can be replaced with the newer "1-6" model which has no stamp.

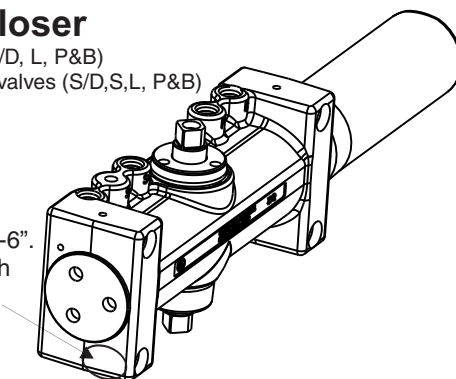

Technical Product Support:  
Monroe, NC 28112 USA  
Phone: 877.974.2255 ext: 2  
Techsupport.NortonRixson@assaabloy.com  
NortonRixson.com